



*how to*  
**PLAN AND CONSTRUCT  
MODERN STORE FRONTS**

**EXTRUDALITE &**

**L.O.F. GLASS PRODUCTS**





[BLANK PAGE]



CCA

HOW TO PLAN  
AND CONSTRUCT

# MODERN STOREFRONTS

OF

EXTRUDALITE AND  
LIBBEY • OWENS • FORD  
GLASS PRODUCTS



LIBBEY • OWENS • FORD  
GLASS COMPANY  
NICHOLAS BUILDING  
TOLEDO • OHIO



# TO BUILD A BETTER MAIN STREET

**A**MERICA'S MAIN STREET is the world's most important shopping center. And the purpose of this book is to provide information which can help to build a better Main Street by adding new beauty and form to the places where buyer and seller meet. • • • No one set of individuals can be wholly credited with the success of America's retail stores. Owners have been quick to sense and satisfy the needs of the buying public. But progressive architects have developed unusual designs to solve the merchant's varied problems of display. And, helping each, the manufacturer has made available building products and practices which can give brilliant new life, color and sparkling originality to modern storefronts in contrast to the drab facades of yesterday. • • • This Manual of Modern Storefronts has been prepared as a source of practical information for all who read it. In it the Owner will find suggestions for improving his present store or for planning a new one. The Architect—and all others who design or build—will find much technical information on planning, construction and the use of modern materials—extruded metal and glass—manufactured by Libbey.Owens.Ford as the tools with which to build a better Main Street in every section of the country.

Successful modern storefronts are the result of the owner's skill in merchandising, the appropriate originality of the architect and the use of modern materials which a progressive manufacturer has made available. The Libbey.Owens.Ford Glass Company recognizes the importance of all three factors. It manufactures and distributes a complete line of products adapted to any type of storefront. This book describes them and tells how they may be used. In presenting it, Libbey.Owens.Ford coordinates all interests toward the end of better merchandising, better planning and construction — and better storefronts along America's Main Street.

STORE OWNER • THE MERCHANT



ARCHITECT • DESIGNER • BUILDER



MANUFACTURER • DISTRIBUTOR



L. O. F. MANUAL OF MODERN STOREFRONTS



# TO FIND FACTS QUICKLY

## STOREFRONT PLANNING . . . . . PART ONE

Planning principles and dimensional data that form a broad basis for the design of any storefront are discussed in this section. Included under various headings are specific suggestions for applying these principles in the development of attractive, modern fronts for particular types of retail stores.

Planning the Storefront . . . . .	6-7
Principles of Show Window Design . . . . .	8-9
Small Stores and Shops . . . . .	10-11
Stores That Sell Service . . . . .	12-13
Large Stores and Markets . . . . .	14-15
Sign Data . . . . .	16
Facade Treatments for Modern Stores . . . . .	17

## EXTRUDALITE DETAILS . . . . . PART TWO

A complete explanation of the L.O.F. storefront metal Extrudalite including quarter-full size drawings of Extrudalite members is covered in this heading. With it are construction details which indicate the wide range of Extrudalite application and embody L.O.F. standards of good practice in extruded metal construction.

What Extrudalite Is . . . . .	18-19
How Extrudalite Works . . . . .	20-21
How to Design With Extrudalite . . . . .	22-23
Spring Tension Sash—500 Series . . . . .	24-25
Spring Tension Sash—300 Series . . . . .	26-27
Lightweight Sash—100 Series . . . . .	28-29
Transoms and Awning Bars . . . . .	30-31
Bulkheads and Facings . . . . .	32-33
Extrudalite Doors and Vents . . . . .	34-35

## L. O. F. GLASS PRODUCTS . . . . . PART THREE

Descriptive and technical data in this section provide a practical basis for the specification and use of L.O.F. Glass Products. Illustrations and scale details under various headings embody approved methods of application and suggest the many varied uses of glass in modern storefront construction.

The Wide Range of L.O.F. Glass Products . . . . .	36-37
Vitrolite Structural Glass—Characteristics and Colors . . . . .	38-39
Construction With Vitrolite . . . . .	40-43
Vitrolux Glass—Description and Performance Data . . . . .	44-47
Construction With Vitrolux . . . . .	48-51
Data on Luminous Vitrolux Elements . . . . .	52-54
Blue Ridge Decorative Glasses— Uses and Selection Data . . . . .	55-57
AKLO Heat Absorbing Glass . . . . .	58
L.O.F. Polished Plate Glass . . . . .	59
Mirrors of Polished Plate Glass . . . . .	60-61
Where to Buy L.O.F. Storefront Products . . . . .	62-64

## L. O. F. MANUAL OF MODERN STOREFRONTS

1042 B997 TCF





EXTRA PROFITS

THAT COME FROM

UP-TO-DATE STOREFRONTS



**P**ROFIT is the chief reason for any store's existence. Obviously the more people entering the store, the greater the profit. But extra profits—success beyond a merely adequate return—can come to the store owner who will capitalize the buying public's instantaneous attraction to a storefront so modern in every detail of design and construction that it proclaims without question the character and quality of the merchandise on sale. No owner would hesitate to invest in larger or more complete stocks if, by doing so, he could swell his profitable income. By spending only a small part of his yearly stock invest-

ment, the progressive merchant can have an up-to-date storefront that will bring the public into his store and extra profits to his till. The buying public is drawn to storefronts alive with stimulating light and color—color that vibrates fresh and clean by day and by night is rich and luminous. With the stamp of public approval come profits to the progressive merchant. And every new buyer, attracted by the gleaming modern beauty of an up-to-date storefront, helps to widen the merchant's opportunities for securing the pleasant things in life that extra profits bring within his reach.

## WHAT EXTRA PROFITS CAN BUY

**A**LL of us yearn for, and look forward to, the time when the things we have dreamed about will become realities. We work long hours to make these personal ambitions come true . . . to give our family the things that have been only dreams before . . . the home in the country, planned and replanned so many times that it seems to have already lived for years . . . a pleasant, comfortable place in which to live, a quiet haven from the hum and hustle of the city and a friendly shelter for the days when children are grown up and business has been given into younger, stronger hands.



Or, perhaps, you have dreamed of travel. Leisurely trips to the fascinating places in our great country . . . journey by sea to far-away lands that capture the imagination. Lucky is the man who can make such dreams come true.

It may be that you are not interested in travel and that your thoughts are concerned with the education of your children . . . to give them the best possible start in the world . . . your dream has always envisioned a scene on commencement day with that child of yours receiving a diploma . . . and all because diligence and good business management on your part has made it possible.



And there are many other things which extra profits can buy . . . things which give the solid satisfaction of ownership or add that extra sparkle to the enjoyment of life . . . that membership in the golf club that is particularly attractive . . . the man

who loves the water always wants to have his own boat . . . the fellow with a hobby wants new and better equipment, a set of power tools, a movie camera. Again, all these represent personal dreams that many of us have hopes will some day come true.

Whatever form your dreams have taken, they generally run up against the everlasting problem of how to pay for them because, in the final analysis, most dreams are luxuries that the average man can obtain solely through the availability of surplus funds. The fulfillment of your dream depends on how many people enter your store. A shabby, outmoded store offers no invitation to the passing shopper. An up-to-date, well planned storefront of modern, colorful glass and gleaming metal does. It is a dramatic appeal to stop, to look, to enter and to buy. Such a storefront is a sound investment which brings those sought-for *extra profits* to the progressive merchant. In this manner his dreams can reach fulfillment.



**I**N all sections of the country, Libbey.Owens.Ford representatives stand ready with experienced advice to help develop up-to-date storefronts that give *extra profits* to the merchant. In this book will be found much practical and trustworthy information on storefront planning and construction with products manufactured by Libbey.Owens.Ford. And for additional information, call or write the L.O.F. factory representative, distributor or dealer in your locality. Consult list on page 64 or telephone book.







## THE MODERN STORE INVITES BUYERS

LIKE a familiar trademark of a fine old firm, a storefront is an indication of business character and substance. And if it is well-planned, modern in construction, generally up-to-date and attractive in appearance, it stamps the owner as an able, progressive merchant with merchandise of honestly represented quality and fair values. The windows may display the merchandise. But it is the facade as a whole that first attracts eyes to it. The modern storefront makes more trade by telling the passing world the nature of the shop and inviting it to enter and buy.

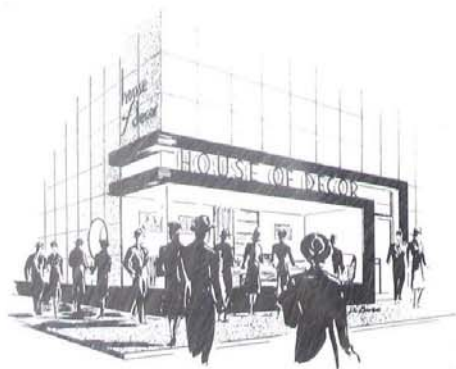



# PART ONE—STOREFRONT PLANNING

## SOUND MERCHANDISING PRINCIPLES GOVERN PLANNING OF STOREFRONTS

RETAIL merchants make profits in proportion to the number of customers that enter their stores and make purchases. And since the front of the store is an important means of attracting people, its planning and construction must be based upon sound merchandising principles if it is successfully to serve its purpose of bringing in trade.

The planning of modern storefronts has become almost a science, for commercial enterprise has researched selling methods; charted customer reaction to forms, arrangements, colors; and measured sales volume in terms of "consumer comfort", a term that runs the scale of the physical and psychological interests of the man who buys. Storefront construction is equally as scientific an art. From facts uncovered by selling research, industry has developed specialized products and practices to give new form and brilliant beauty to the place where buyer and seller meet.

Any storefront, however large or small, is essentially a three-dimensional advertisement of the goods offered for sale. It has a three-fold function: to sell the name of the store owner; to display his product; and to afford access to the interior.

The entire storefront begins to function as an advertisement from a distance. It reflects the style and character of the establishment. It may appear dignified or reserved, novel and progressive. It may be so designed as to suggest luxurious or economical merchandise, and thus help to attract into the store the buyer to whom the goods will appeal.

As the buyer comes closer to it, details of the storefront should confirm his distant impression and invite inspection of merchandise. Windows are primarily for displays that will influence the buyer to enter the store. And this should always be made easy through an attractive and convenient arrangement of the vestibule and entrance.

Different types of stores obviously require different storefront treatments in order to reflect the character of the product sold and to provide for its attractive display. The size of the store — that is, its interior floor area — also governs the size of the vestibule and entrance to provide adequate traffic capacity.

Stores for small objects — such as bakeries, jewelry stores, delicatessens, liquor and tobacco shops — require comparatively small windows with floors set higher from the ground than stores which display

large objects such as automobiles, furniture, clothing, musical instruments or sporting goods. Stores that have a wide range of display requirements, including most department stores and drug stores, require windows that offer a maximum of flexibility in the arrangement of displays. Shops that render a service rather than sell goods, such as restaurants, barber and beauty shops, ticket offices and the like, may have windows designed to express the character of the service rendered or to reveal the interior, which, in a sense, becomes the display itself.

Common to every type of store is the need to capitalize every advantage that retail merchandising and modern industry have made available. To accomplish this result unfailingly, the utmost ingenuity may be necessary to overcome physical handicaps of an unfavorable site, the compromises of a restricted budget or unusual demands of an out-of-the-ordinary merchandising policy. But the most intricate and involved storefront problem can easily be met today by the use of modern materials and advanced methods of building design.

ONE of the newest developments in modern merchandising is recognition of the night-time display value of luminous storefronts. The advertising effectiveness of the whole facade of any shop can be capitalized by making it stand out, after hours, through use of rich and glowing colors softly or brilliantly illuminated. Thus, the up-to-date storefront, properly constructed with modern products, can be designed not only for day-time attractiveness, but for the night-time attention value of luminous color as well. In this new possibility lies great opportunity for retail merchants and for the designer who serves them.

Buyers are attracted by clean-cut forms and smooth surfaces, are stimulated by color and light. Because of this, merchants are recognizing more and more the sales values that lie in the imaginative use of glass, metal and glowing colorful light.

Today, all these elements are important parts of the designer's building vocabulary. Storefront metal of extruded aluminum or bronze, lightweight but tough and strong, can meet the specifications of any plan. Held by it safely and permanently is glass — glass that can be almost endlessly colorful; that is transparent, translucent or opaque, plain or textured, resistant to heat and cold, tempered to unbelievable strengths. Because these are now so easily available, the miracle of luminous surfaces can be accomplished. Color and light can be made to glow, sparkle or blaze at the will of the designer, giving new fire of interest to any type of market place.



# PRINCIPLES OF

**S**HOW WINDOWS of any size or type have *display* as their chief reason for existence. Therefore, principles of show window design can be standardized in relation to the ease with which people can view the window's contents. This involves sight lines to determine the most practical size of the glass area.

**SIGHT LINES** are normally taken from an average eye position 5' - 3" above the sidewalk and 1' - 3" from the window face for display areas on the first floor and those in a basement. See diagrams A and B at left. An eye position about 25' from the window face will establish practical limits for mezzanine or second floor show windows as indicated in sketch A.

In all cases projection of sight lines should permit concealment of lighting fixtures above and below display areas and also at show window jambs when displays require lighting from one or both sides.

A comfortable viewing angle is 30° on each side of the perpendicular in both horizontal and vertical planes. Within this 60° cone, the eye sees quickly and without any appreciable physical effort of focusing. But, because the eye can shift and accommodate so quickly to a new focus, it is practical to plan show windows which encompass horizontally two or more "viewing angle areas".

**THE OPTIMUM VIEWING PLANE** is the limit of the viewing angle determined by the physical enclosure of a display area. It indicates the best display location, and thus largely influences location of a display area background. See diagram C below.

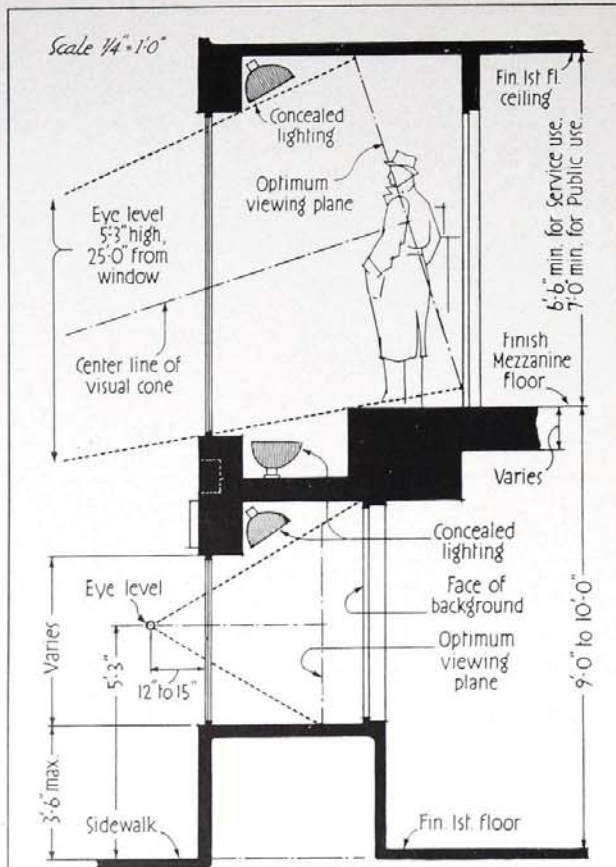

**A** SIGHT LINES - Ground & Mezzanine Windows

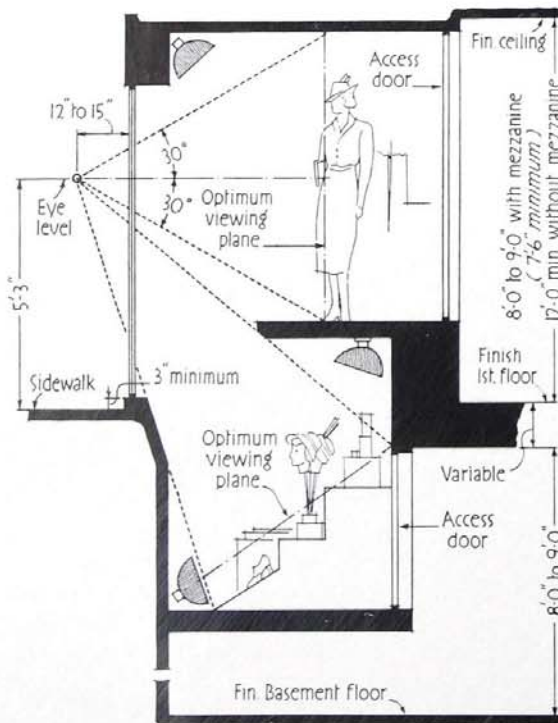

**B** - SIGHT LINES = Ground & Basement Windows

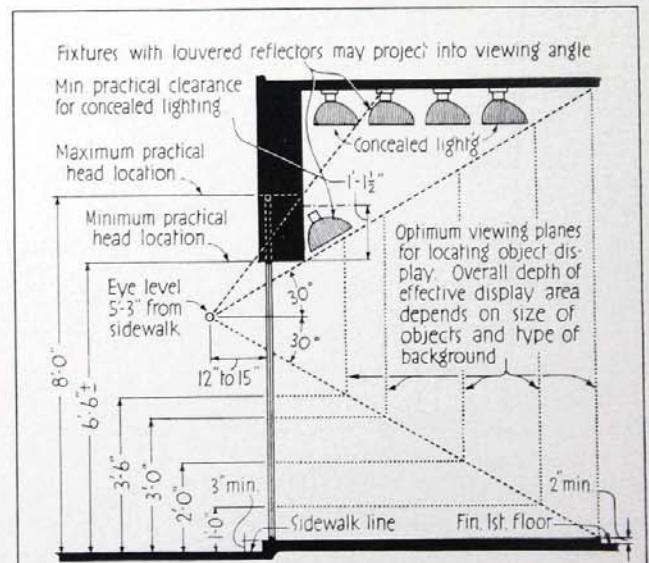

**C** - OPTIMUM VIEWING PLANES



# GOOD SHOW WINDOW DESIGN

**D**IMENSION data in the table below were developed from application of these planning principles. They give average range of critical dimensions for various types of commonly used show windows, but it should be borne in mind that they are to be regarded primarily as a guide to good show window design and not as inflexible stand-

ards. Similarly, the lighting wattages in this table should be looked upon as guides and not as rigid criteria. Requirements will vary with the general character of adjacent establishments and with the specific nature of the merchandise displayed.

Show window lighting wattages listed should be multiplied by the following

factors based upon average brightness of typical commercial areas:

Main shopping centers in cities	1.0
Secondary shopping centers cities or main centers towns	.75
Neighborhood stores small towns or industrial districts	.50
Brilliantly lighted areas, as "White Way" districts	2 to 2.5

**STORE FRONTS - AVERAGE DIMENSIONS** (Figures indicate range of sizes in common use)

STORE	BULK-HEAD HT.	GLASS HT.	WIN-DOW DEPTH	LIGHTING in Watts per Lin.Ft. Outlets 12"-15" o.c. (SEE TEXT)	WINDOW BACKS	STORE	BULK-HEAD HT.	GLASS HT.	WIN-DOW DEPTH	LIGHTING in Watts per Lin.Ft. Outlets 12"-15" o.c. (SEE TEXT)	WINDOW BACKS
Art	2'-2"	3'-6"	3'-0"	100	Neutral color, suitable for tacking; no portion of window more than 3'-6" from access door	Furrier	1'-8"	6'-0"	3'-0"	200	Semi-closed or closed, rich wood preferred
	3'-0"	6'-0"	4'-0"	200			Spotlights and/or footlights; lenses necessary to protect furs				
Auto	0"	8'-0"	6'-0"	300	None	Grocery	1'-8"	5'-0"	2'-0"	150	Open or low rail - clear view into store
	12"	10'-0"	8'-0"	500		Haberdasher	1'-6"	6'-0"	3'-0"	200	Closed
	Access window sometimes needed					Special lighting effects; ceiling lights lowered recessed spotlights	Varied stock	2'-2"	7'-0"	4'-0"	
Bakery	2'-0"	5'-0"	2'-0"	150	Glass, wood. Screened vent ducts to outer air; assume size of 100 sq. in. per 1000 watts	Haberdasher	2'-6"	5'-0"	2'-6"	150	Closed
	2'-6"	6'-0"	3'-6"			Limited stock	2'-8"	6'-0"	3'-0"		
Candy	2'-0"	5'-0"	2'-0"	150	Glass, wood. Screened vent ducts to outer air; assume size of 100 sq. in. per 1000 watts	Hardware	1'-6"	6'-0"	4'-0"	200	Closed
	2'-6"	6'-0"	3'-6"				2'-6"	6'-0"	3'-0"	Additional spotlights and outlets for mechanical contrivances	
Books	2'-4"	4'-0"	2'-0"	100	Closed, wood; or partially open possibly with shelving for displays	House Furnishings	1'-6"	6'-0"	4'-0"	200	Closed
	3'-2"	6'-0"	3'-6"				Perhaps varying levels	10'-0"	6'-0"	Additional spotlights and outlets for mechanical contrivances	
Clothing Men's	1'-6"	6'-6"	4'-0"	200	Closed, 1 access door per window; partitions or screens often divide window into 4' to 6' units	Hats Men's	2'-0"	6'-0"	3'-6"	200	Closed - 1 access door
	1'-10"	8'-0"	6'-0"				2'-4"	8'-0"	4'-6"		
	4 sq. ft. area per "torso" form; 40" to 50" high							Additional spotlights and base outlets			
Clothing Women's	1'-0"	7'-0"	4'-0"	200	Closed, 1 access door per window; usually light hard woods	Jewelry Inexpensive	2'-8"	4'-6"	2'-6"	150	Closed, removable; provide access passage
	1'-3"	9'-0"	6'-6"				3'-0"	6'-0"	3'-6"		
	"Style stages" 10" to 14" high at rear							Additional spotlights and base outlets			
Dairies Delicatessen	1'-8"	5'-0"	2'-6"	150	Closed or open; access doors 1'-6" by 4'-0" to 2'-0" by 5'-0", max. reach 3'-6". Vent unless refrigerated; see "Bakery"	Leathergoods Luggage	1'-6"	6'-6"	6'-0"	200	Closed, provide shelves 15" to 24" apart for luggage displays
	2'-4"	7'-0"	4'-0"				2'-0"	7'-6"	8'-0"		
Drug	2'-0"	6'-0"	2'-0"	200	Partially closed - openings to view interior; provide access passage	Radios Refrigerators Sporting Goods	1'-6"	6'-0"	3'-0"	200	Open or closed
	2'-6"	8'-0"	3'-0"				2'-0"	8'-0"	6'-0"		
Florist General	1'-0"	6'-0"	3'-0"	150	Open - additional glass and metal shelving - Ventilated	Shoes Men's	1'-10"	6'-0"	2'-0"	150	Closed
	Water-proof floor, drainage	8'-0"	6'-0"				2'-2"	7'-0"	4'-0"	1/2 sq. ft. per pair shoes	
Florist Hotel, Cut flowers	3'-0"	4'-0"	3'-0"	100	Closed - additional glass and metal shelving. Vent unless refrigerated	Shoes Women's; or Men's and Women	2'-0"	5'-0"	3'-0"	150	Closed
		5'-0"	4'-0"				2'-4"	6'-0"	4'-6"	1/2 sq. ft. per pair shoes	
Furniture	9"	9'-0"	8'-0"	250	Closed; access doors, 4'-0" x 6'-8"	Service Barber Beauty Cleaner and Dyer Laundry Tailor	1'-6"	6'-6"	1'-6"	200	Preferably open; interior appearance important
	1'-2"	11'-0"	12'-0"				2'-0"	8'-0"	5'-0"	Additional base, floor and wall outlets and spotlights	



# SMALL STORES AND SHOPS

DISPLAYS of comparatively small objects which are best seen relatively close to the eye, gain in attention value when the floor of the window (bulkhead height) is brought up from 18" to as much as 31½' above the sidewalk grade. Practically any type of object which the buyer would normally examine by holding in his hand falls into this class of small objects. Included are food products, books, cut flowers, haberdasheries (other than suits), hardware, jewelry, liquor bottles, millinery, shoes and other merchandise of similar size and character.

Recommended dimensions for bulkhead height, glass height, window depth, for stores in this category are given on page 9. Judgment must be exercised in the application of these average dimensions, however, because local habits and trade customs, as well as the quality of the goods displayed, may require larger window areas than are indicated. In general, high-grade shops which seek to "institutionalize" their character choose to display only a few items at a time. Show windows are often small in size, but the general facade of the store is comparatively more elaborate.

Stores selling less expensive goods may require the largest practical windows if their policy of "mass selling" requires bulk showing of many items within a single display area.

In general, small stores require unusual ingenuity in planning, construction and in the disposition of materials. The facade must make up in attention-value what it lacks in size to compete successfully with its neighbors in attracting buyers.

For this reason, plans of small storefronts show wide variety. A number of plan suggestions that have

proved unusually successful are shown below as well as four methods of solving the problem of planning for a building entrance within the same facade.

Diagrams and tabular data relating to vestibule dimensions indicate average standards of good practice in four general types of small stores. In every case adjustments can be made depending upon the location of the store, the character of the facade and the physical requirements of display as determined by the merchandising policies of the owner.

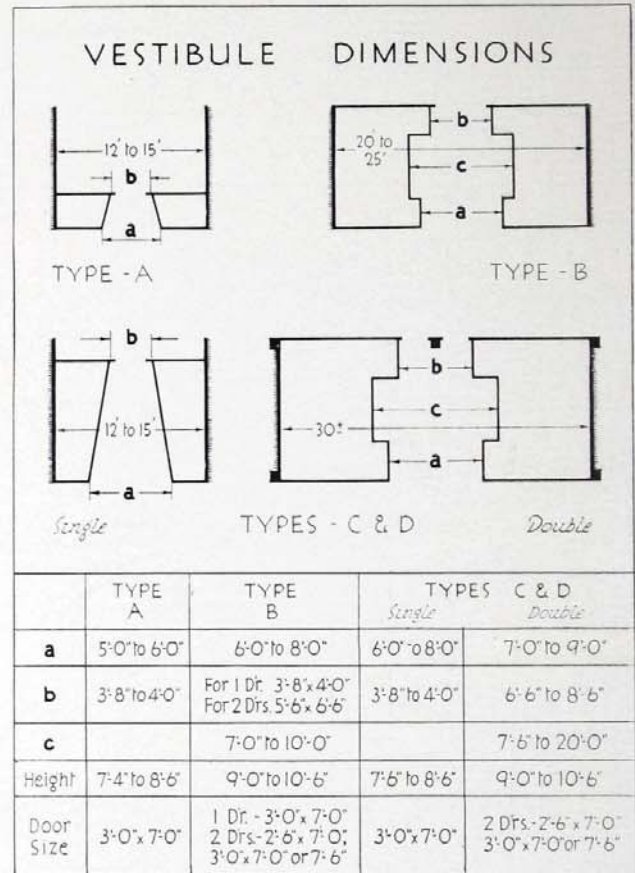

Below at the left are shown logical arrangements for a small store frontage requiring two entrances. Display areas are increased if types 3 and 4 are practical. At the right are six plan suggestions for narrow storefronts. Choice of deep or shallow windows and vestibules depends on depth of store building and owner's display requirements.

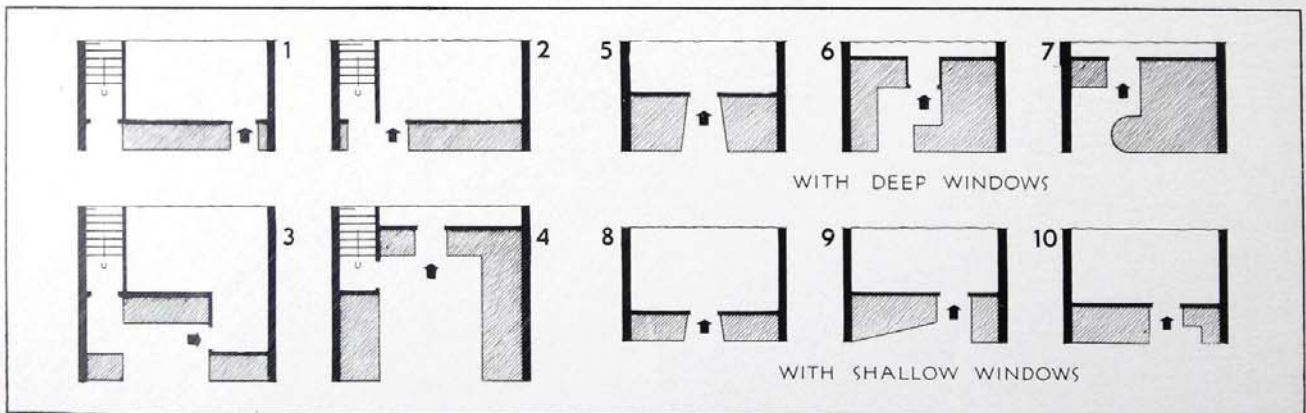





## PLANNING WITH FORM, LIGHT AND COLOR

WHEN the display area of a show window is purposely restricted by high bulkheads to bring objects close to the eye, the treatment of the whole store facade must be given distinctive character to attract the attention that a larger display might otherwise secure. Facades of small stores can appropriately be startlingly unusual provided that the owner's requirements for display are fully satisfied. The architect can do much to create an outstanding plan. He can justifiably use combinations of

strong color in his design; and with them light can be employed to accent the design during the day or to make the entire facade glow with compelling radiance at night. Today's modern materials — extruded metal and strong, colorful glass products — give the widest latitude to the architect's constructive imagination. They can be adapted to an endless number of storefront designs and give to both architect and owner a means for planning with new forms, glowing color and brilliant light.

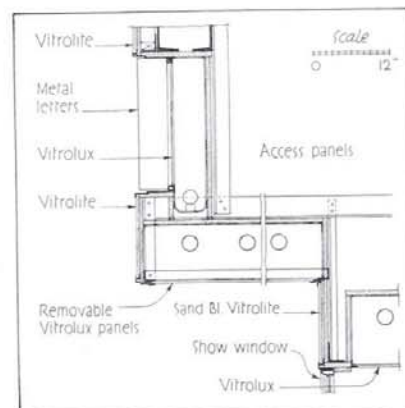



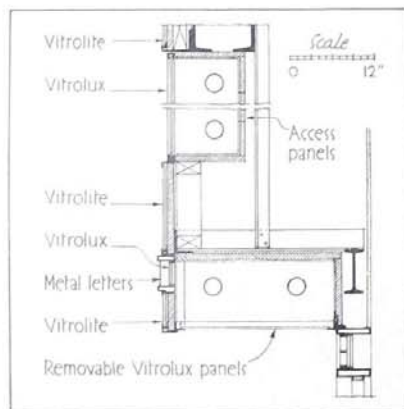
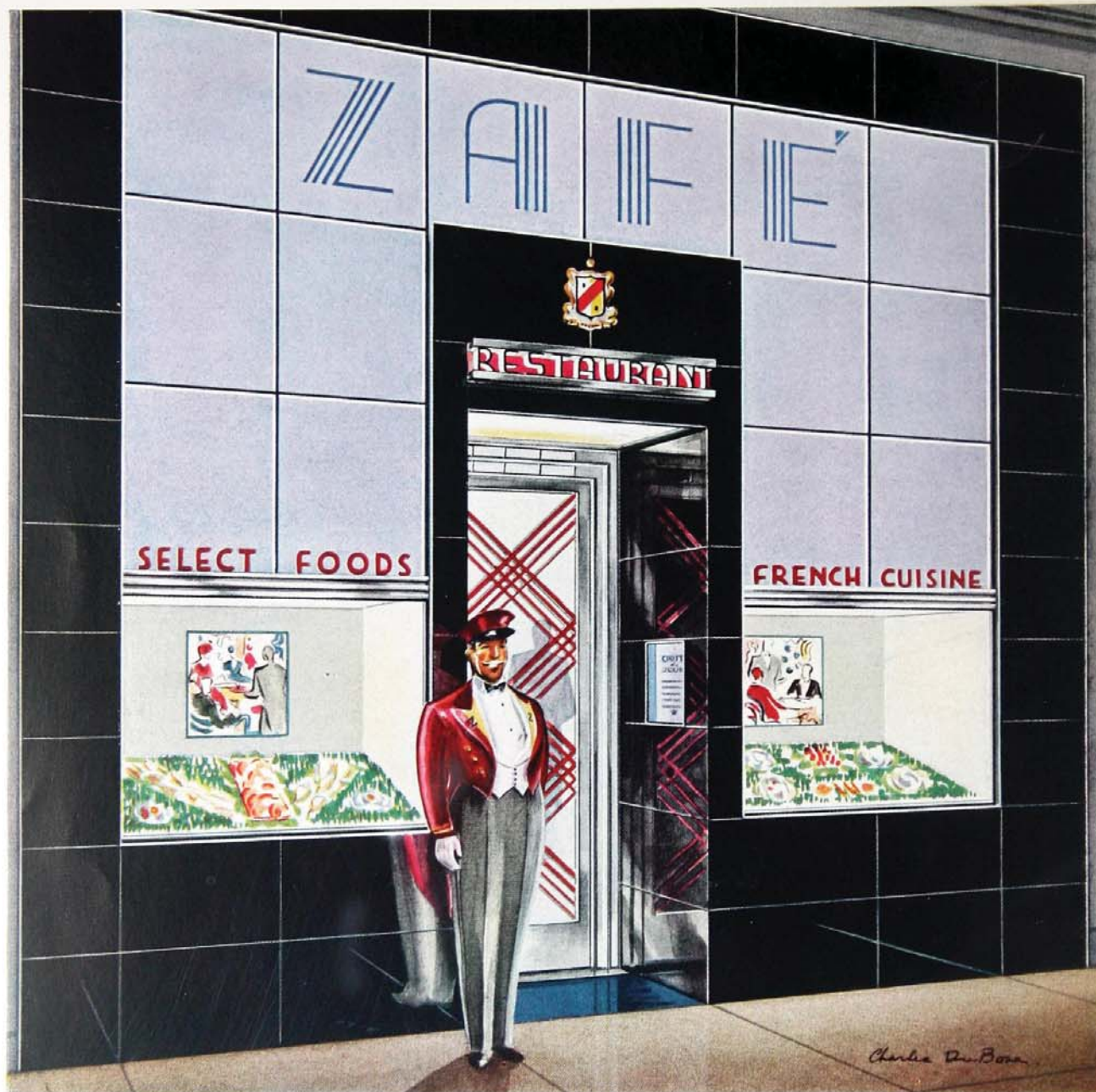

## LET THE FRONT REFLECT THE SERVICE

INTANGIBLE services cannot be sold by ordinary storefront displays. Customers cannot estimate the skill of a hairdresser or barber, the efficient service of a brokerage house or the excellence of a restaurant's food by samples displayed in a window. But they can tell a great deal about the standing and quality of a service establishment by the storefront itself. If the facade is up-to-date, it reflects the success of the entire establishment. If it is obviously

high in the quality of its material and design, a storefront suggests that the proprietor appreciates quality in service. Attractive originality draws customers who seek both excellence and individuality in the service they are buying. Skillful planning and the use of colorful glass with extruded metal enable the store owner to express in the facade of his shop the very features his customers desire and thus draw buyers of whatever services he may offer.



# STORES THAT SELL SERVICES

WHEN a store sells a service rather than goods which can be appraised visually, it increases the merchandising task which the store front must accomplish by itself. In this group fall restaurants, bars, tearooms; barber and hairdressing establishments, custom tailors, cleaners and dyers and laundries; repair shops, ticket offices and such store-type office space as is customarily used by realtors, insurance brokers, branch banks and the like.

In all instances it is the store facade rather than the show window display that expresses the character and quality of the establishment. Three types of window treatment are open to choice.

The first makes the storefront a "picture window" which reveals activities within the store itself. This treatment calls for good illumination of the interior, and, of course, an interior treatment that makes the customer want to enter. Size of the window is immaterial, being governed wholly by sight lines which vary with the viewing point from which the interior will be most commonly observed. A window with a relatively high bulkhead and low valance will suffice to show the interior to persons passing on the sidewalk.

In a second type the window is subordinated as a mere pattern in the facade. Often the window may be of unusual shape and so related to the entrance itself that the shopper is almost compelled to enter.

A third type may combine these functions or even make use of attention-getting displays more or less related to the kind of service offered within. In general, however, reliance must be placed upon the impression created by the entire facade rather than that formed by objects displayed or visible through the window. A particularly effective service storefront is that which contains no window at all, or, at most, a window area glazed with opaque, colored or patterned glass. Here the designer can give full play to his imagination, using form, color, lighting effects and the brilliant smoothness of extruded metal and modern glass products to achieve individuality and high distinction, two qualities which always appeal to the best trade in any town.

Average dimensions of windows suitable for stores and shops that sell services are given in the table on page 9. Recommended dimensions for vestibules and entrances leading to such service stores are given in the table on page 10. Normally, windows of service stores can be very shallow and their doors can be as close to the street line as local building regulations permit, thus increasing the effective floor area of the shop within.

The sketches below suggest the virtually limitless design possibilities of "service storefronts." An attractive treatment of the whole facade is usually more important than display space. Some unique device such as that shown in the shoe-repair shop-front illustrated is often desirable. Here the potential customer's own footwear is reflected in the bulkhead mirror for comparison with shoes in the window.

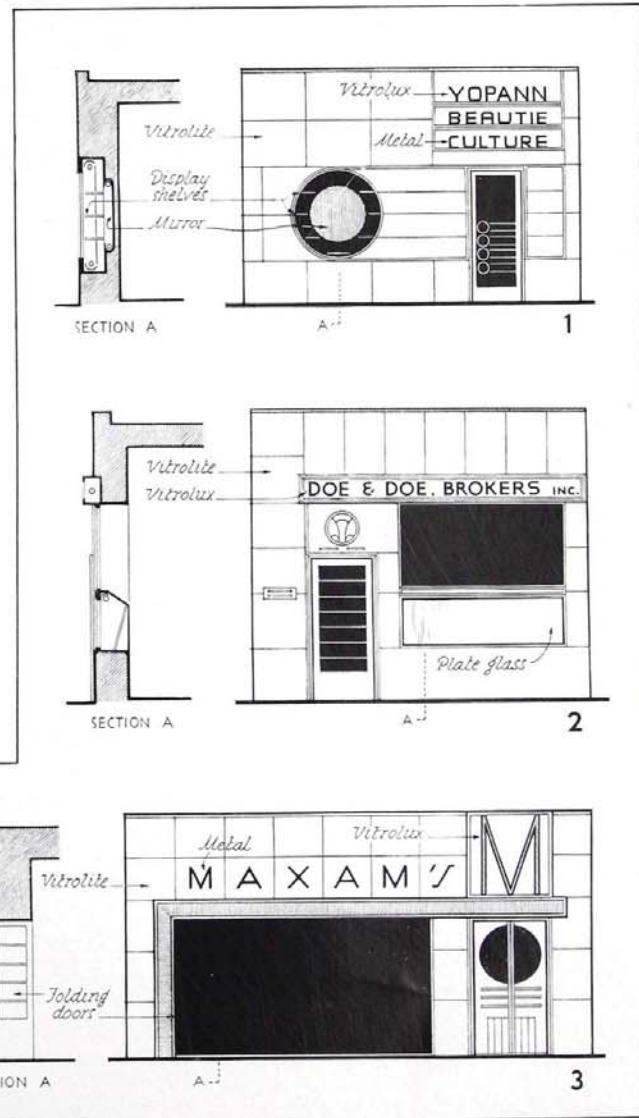



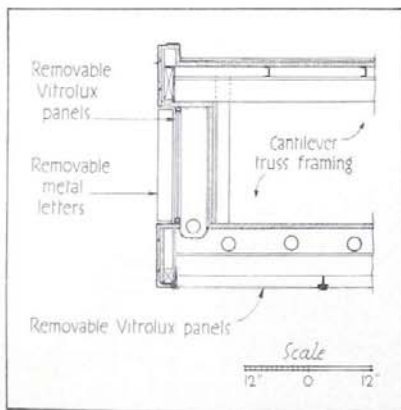

## COMPELLING ATTENTION WITH LIGHT

FOR sheer attention value, no shape, form or material can compete with light. A brilliantly lighted window display steals the show from its dimmer competitor next door. The well-lighted marquee or entrance draws the crowd from the obscure doorway nearby. The luminous storefront in which the whole facade is made to glow in rich color and interesting pattern will catch the eye blocks away. In light — used in any of these ways — the owner and storefront designer have an indispensable aid.

Glass is the material which above all others is intimately associated with light. Its use in show windows and display cases is traditional. Today, a great variety of glass products makes it possible to employ the compelling power of light through glass over the entire facade, not only to show the merchant's wares to best advantage, but to identify his establishment unmistakably. Glass surfaces of high luster held in gleaming metal form a structure of compelling attraction and enduring value.



# LARGE STORES AND MARKETS

STORES with extended street frontages permitting the use of several units of show windows, require quite different facade treatment from that logical for small stores and service shops. Into this class fall most department stores, large drug and grocery stores, clothing and drygoods establishments, automobile salesrooms, furniture stores and other marts where the variety of the products for sale or the size of the units demands extensive floor space in display areas.

Entrances to such establishments usually require broad vestibules and multiple doors to handle traffic easily. Also the entire entrance area generally needs a treatment that creates a powerful invitation. A deep, brilliantly lighted vestibule flanked by small display windows, a large marquee with a dominant sign or broad areas of color are elements which may be variously adapted to serve this purpose. When structural conditions or building regulations prevent use of projecting features or deep vestibules, the facade itself requires a more compelling design treatment to which color and the smooth surfaces of glass and metal products can contribute much.

In all large stores of whatever type, display windows are the most important elements of the entire storefront area. In general, display areas must be large and usually deep, particularly for stores selling such things as furniture or automobiles. Also they must generally be so planned that they are easily adapted to frequent changes of displays. This holds with special force in display areas of department stores which commonly show a wide variety of goods in displays that are changed often and vary widely with seasonal merchandising activities.

Because display managers strive for "continuity of effect" when dressing a group of large windows, as continuous a glass area as possible is desirable. The position of columns between units or groups of win-

dows often determines the feasibility of such displays. If columns are set behind the glass line at least 2 or 3 feet, displays may continue without apparent interruption. Columns breaking the glass line or those which are set back only a few inches from the surface of the glass make it difficult to produce a successful display continuity.

Set-back columns are almost mandatory in structures housing large grocery stores or drug stores. And in many food markets, where windows are movable to permit open-air selling, set-back columns should be provided.

AN important consideration in the large store, from the point of view both of design and of merchandising, is unity of effect and compelling power. Unlike the small store which usually contains one unit of display on which it wishes to focus attention, the large store has a multiplicity of units, some of which may be treated as continuous display, others with brilliant contrast. An example of this may be adjacent department store displays of winter sports clothes set against a snowy landscape and southern sports clothes against a background of southern landscape. In the design of the entire structure and its skillful use of form, light and color will be found the means for unifying these multiple units of display, whether continuous or contrasting, into the integrated unit of the large store.

In the majority of cases, the large storefront requires large display windows with low bulkheads, fairly high glass areas and considerable depth. The lighting equipment must be planned for utmost flexibility, for such windows must be capable of a wide variety of dressing treatments. In a sense, these windows are theatrical stages in which backdrops, furnishings and lighting emphasis are varied at will.

Column locations govern the character of window dressing in continuous windows forming the front of a large store. If columns break the glass line or are positioned immediately behind the glass, they require individual treatment of adjacent displays. When the columns are set well behind the glass and the storefront is carried on cantilever construction, several adjacent windows can be dressed as a single unit by carrying the uniform treatment in front of the supports. The impression of display continuity is enhanced by facing the columns with mirror.

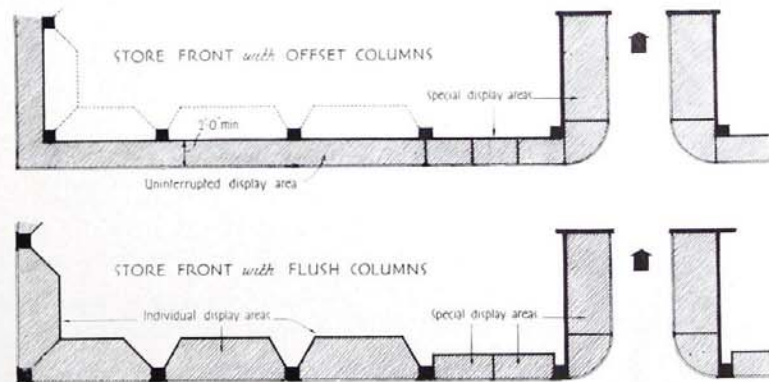



# S I G N S

**SILHOUETTE** signs are effective up to about one thousand feet, when width of a letter stroke is 15% of letter height. ( $W/H = 15$ ). Very thin letters (under 5%) or very thick (over 25%) give poor visibility. *To find letter heights for ready recognition:* Determine net luminous area (lighted background less area of letters). On Chart I read from top, through curve of desired brightness to distance factor, left. Divide desired maximum legibility distance in feet by factor. Apply result to scale of maximum distance for ready recognition on Chart II. Read left to predetermined letter proportion ( $W/H = \%$ ) then down to find minimum practical letter height. For height with greater legibility giving "desirable publicity value" under similar conditions, divide result by 0.70. *To find maximum distance for ready recognition,* knowing desired brightness, letter height and proportion: reverse procedure, beginning with height. For distance of "desirable publicity value" multiply result by 0.70.

**ENCLOSED** lamp signs may vary widely in size and character depending upon the translucent materials employed for the letters and the depth of the lamp housing. For letter dimensions see Table I. Lamp spacing is based on 6" centers, from 4" to 6" behind opal glass letters. Read wattages for clear or inside frosted lamps from Table II. For increased wattages for colored lamps or color screens see Table III.

**EXPOSED** lamp signs are rarely satisfactory on storefronts except when gaseous vapor tubular lamps of comparatively low brightness replace ordinary lamps. For design of such signs consult a specialist.

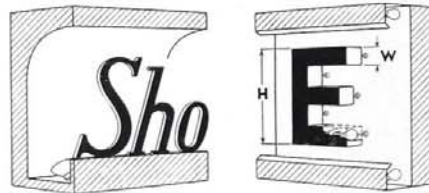
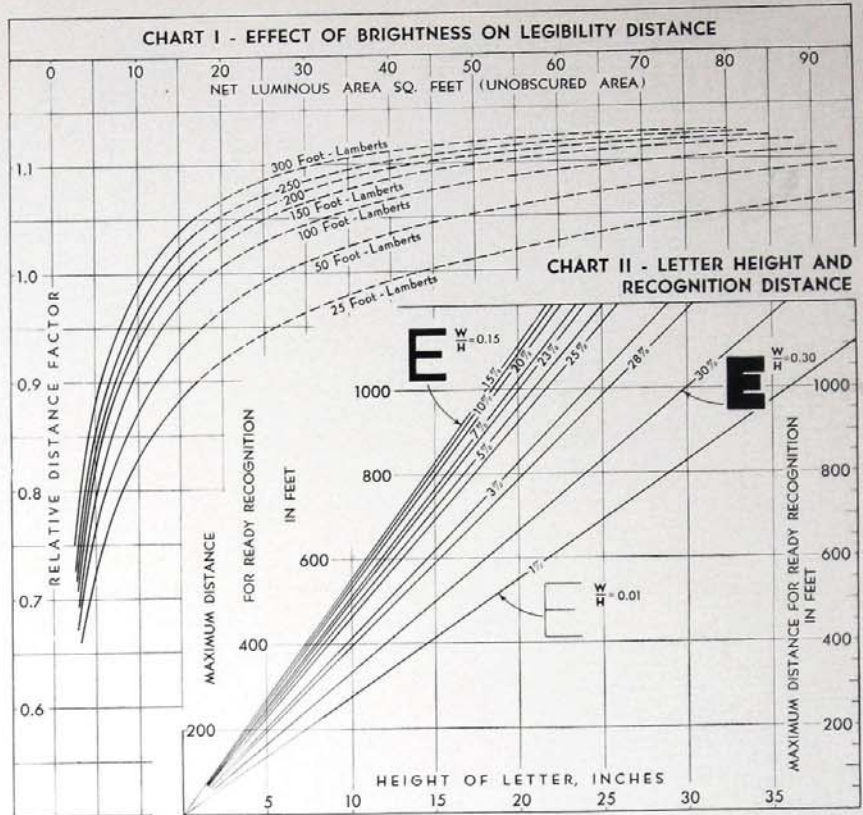

**SILHOUETTE** signs shown above have background brightness expressed in foot-lamberts in Chart I. Use 100/300 Ft.-Lamberts in high brightness districts. (See 1st col. Table II, Items 1, 2 and 3). Use 50/150 Ft.-Lamberts in low brightness districts.

**ENCLOSED** lamp signs such as that below can be designed from data given in tables based on lamp spacings shown in the diagram below. For data on design of luminous elements, see pages 52 and 53.

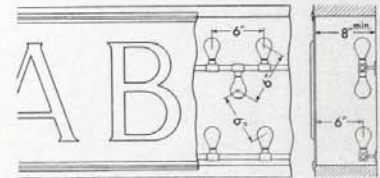

Effective Reading Distance	Maximum Viewing Distance	Letter Height	Letter Width	Letter Stroke	Space Between Letters
200'	400'	10"	6"	2½"	4"
300'	600'	14"	8"	2½"	5½"
400'	800'	19"	11"	3"	7½"
500'	1000'	2'	14"	4"	9½"
750'	1500'	3'	2'2"	5"	1'2½"

Normal "White" or Inside Frosted	10	15	25	40	60	100*
Daylight Blue	15	15	25	50	60	100
Yellow	10	10	25	50	60	100
Amber-Orange	10	10	25	50	60	100
Green	25	25	50	50	100*	150
Red	25	25	50	60	100	150
Blue	50	50	50	60	150	200

\* 100-watt lamps or larger require color hoods.

BRIGHTNESS FACTOR	Greatest Viewing Distance in Feet									
	50	75	100	150	200	300	400	500		
1. Brightest (Times Sq. New York)	40	40	50	50	60	60-75*	75*	75*		
2. Other Large City Squares	25	25	40	40	40	50	50	60		
3.	Bright	25	25	25	40	40	40	50		
4. Most City Squares		Medium	15-25	25	25	25	40	40	40	
5.			Dim	15	15	25	25	25	40	40
6.	Bright	15		15	15	25	25	25	40	
7. Business Sections		Medium	15	15	15	15-25	25	25	25	25-40
8.			Dim	15	15	15	15	25	25	25
9. Small Cities and Large Towns	10	15		15	15	15	25	25	25	
10. Dark Factory Districts, etc.	10	10-15	15	15	15	25	25	25		

\* Preferably use not over 60 watt lamps and space closer than 6 inches on centers.  
All values in this table computed from the formula: Lamp Watts =  $\frac{10^3 \text{Max. Viewing Distance, Ft.}}{\sqrt{\text{Brightness Factor}}}$



# AREAS ABOVE THE STOREFRONT

WHEN a store tenant or owner commands a facade area substantially larger than that required for show windows and entrance, he has a valuable opportunity to increase the dominance of his store by making the entire facade function as an advertising sign.

This opportunity comes quite often. It occurs when small stores with high ceilings require relatively small display windows. In two-story structures the second floor can be treated as an integral part of the storefront when it is controlled by the tenant of the first floor space. And in one-story stores, a false front may often be erected to create an impression of height, thus adding an air of dignity and importance that might otherwise be lacking.

Development of such facade areas into compelling advertisements for the store itself, obviously requires an adherence to whatever character has been developed in the storefront proper. But through the imaginative use of various surfacing materials and through employment of both light and color, facades

above the storefront may be made to pay attractive dividends to the owner who is wise enough to make full use of the potentialities at his command.

Illustrated below are two examples of upper facades used as backgrounds for identifying signs. There are an infinite number of other possibilities when the surfacing material is of an opaque character. The entire area may be faced with colorful Vitrolite or mirror and floodlighted from a source below, concealed in a marquee or projecting awning box.

Use of second floor windows trimmed with Vitrolite or colored mirror is another practical and effective method of developing a facade area and at the same time enlarging the display capacity of the store.

AGAIN, the sign itself may be lighted in silhouette and the facade merely outlined in ribbons of concealed light. And where practical, a particularly effective means for developing attention value is to erect the upper structural members far enough back from the show window line to provide lamp space behind a facing of colorful Vitrolux supported with Extrudalite.

With Vitrolux used in this manner, luminous color can be made to dramatize the store at night. In Europe luminous facades have been designed to hold opaque letters at night, arranged as a huge sign that proclaims the bargains of the moment. By day the luminous areas appear as richly colorful opaque glass with smooth, easily maintained surfaces.

Indeed, with light-controlled, perhaps, on various circuits to permit changes in both color and intensity—and glass products held in Extrudalite, the architect and store owner command unlimited possibilities of dramatic design and compelling advertising. Their employment is limited only by the creative imagination of the architect or designer and the merchandising policies of the merchant.

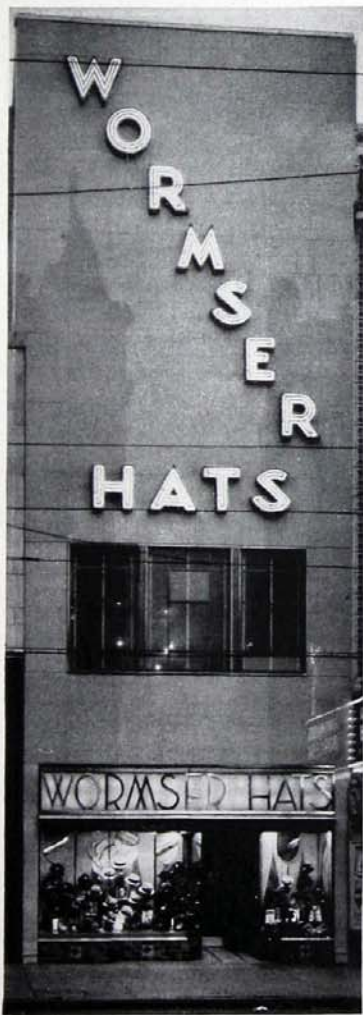

These and the photographic illustrations that follow show applications of various L.O.F. glass products, but do not illustrate the use of Extrudalite, details of which appear on pages 19 to 35, inclusive. Through the use of Extrudalite with L.O.F. glass products, store facades may be luminous or opaque in any desired combination, with all metalwork harmonious from sidewalk to roof.

Two striking facade treatments, both faced with colorful Vitrolite. The facade sign at the left, of the silhouette type, attracts instant attention in this daytime view and at night is emphasized by lights concealed behind the surfaces of the letters themselves. At the right the sign, an integral part of the Vitrolite surface, is striking during the day and is made brilliant at night by floodlighting concealed in the hood over the entrance and show windows.





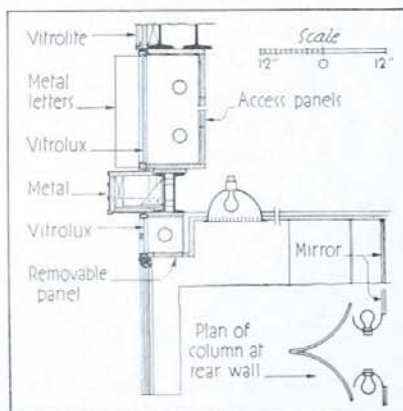

## FOR EVERY TYPE OF STOREFRONT

ONE factor common to all stores and the universal problem of all retail merchants is the necessity of keeping pace with competition. And since the storefront creates the first impression on passing traffic, it must be unusually attractive if it is to compete successfully with its neighbors. It must proclaim in dramatic terms that "here is an up-to-date store, fresh stocks, progressive service, the kind of goods you want—come in and buy". In glass and gleam-

ing metal—the most modern products for storefronts—property owner, tenant and architect alike have at hand materials that are everlastingly fresh, clean and brilliantly new-appearing. These, together with glowing color and light, are design elements of vast importance to the storefront planner. Their enduring qualities, their perpetual youthfulness makes them adaptable to any modern storefront design and an economical investment for every type of store.



# PART TWO — EXTRUDALITE



Metal sections of extruded aluminum or bronze with a modern appearance, durability, strength and simplicity of design that make them ideally suited to a wide variety of uses in the construction of any type of storefront

**E**XTRUDALITE storefront metal includes three types of self-supporting sash and a series of related members so complete that it can be used for constructing

entire storefronts of any size or design. In this list are members designed to secure such materials as Vitrolite or Vitrolux in connection with sash assemblies, thus making Extrudalite particularly adapted to the construction of the most modern storefront utilizing the possibilities of colorful glass facings and areas of luminous color as elements of design.

Because Extrudalite enjoys such a wide field of use, its name actually applies to a system of modern construction in extruded metal. As indicated by the details appearing on pages 24 to 35 inclusive, Extrudalite sections are interchangeable to a large degree. They are easily installed over any rough construction and are adapted for use with facings of brick, stone or metal as well as structural glass.

The sash is the key member of Extrudalite. Of the three standard types, two are similar in operation and differ chiefly in depth of reveal and appearance. These — the "500 Series" and the "300 Series" — embody a simple but effective means of limiting and distributing pressure against plate glass through automatic "spring-tension control". This, with the nor-

mal rigidity of extruded metal, holds glass and sash constantly in alignment, reduces the possibility of strains resulting from unequal pressure and eliminates the commonest cause of glass breakage.

The principle of pressure distribution and control also reacts to absorb strains arising from shock, vibrations and expansion or contraction of the glass. Because of this, pressures are evenly cushioned and stabilized throughout the length of the sash. All this is accomplished by a simple spring clip held in a gear rack and tensioned by a setting screw at the rear of the sash. This spring clip allows only a *predetermined amount of pressure* to be applied through the setting screw and automatically makes it impossible to exert too much or too little.

Extrudalite Lightweight Sash — designated as the "100 Series" — does not contain this automatic pressure control, for the assembly is secured by face screws. But pressure is equalized partly through the rigid alignment of extruded metal and partly by a tongue-and-groove that provides a wedging action. This allows adjustment of face to glass thickness and also relieves undue pressure against the glass.

In appearance, standard Extrudalite sections eliminate optical illusions that make plain, flat metal appear wavy. Each area is slightly reeded to form natural highlights against shadow lines. Thus the attractive characteristics of Extrudalite are retained even though maintenance and cleaning is casual.

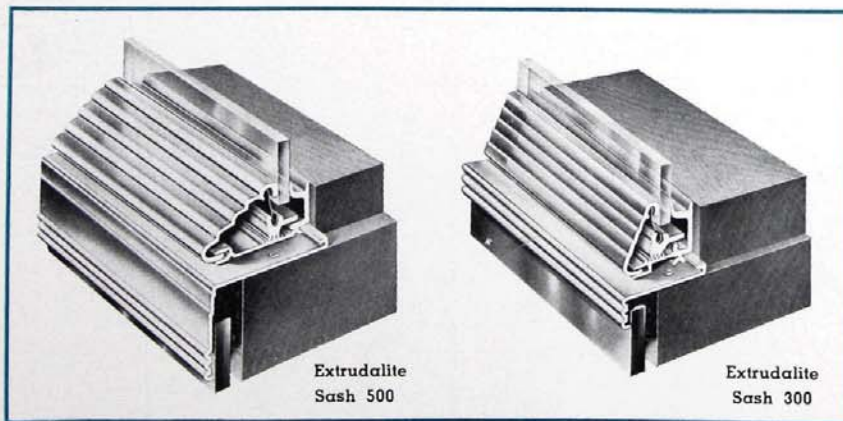



# EXTRUDALITE METAL SASH

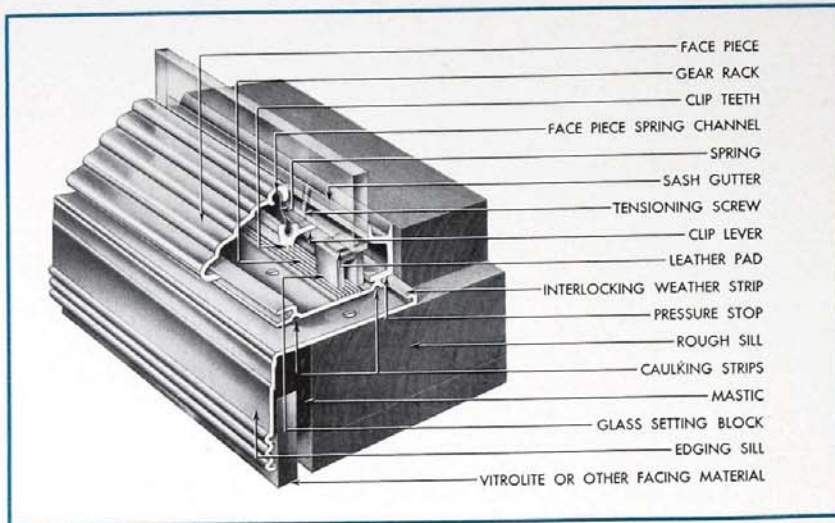

**500** A sash with a comparatively deep reveal. It embodies a spring-tensioning action to control, distribute and absorb pressure against the glass face and thus eliminate breakage. Automatic pressure adjustment is controlled through spring and clip. Clip teeth slide over gear rack until face piece contacts glass. Pressure then exerted on clip lever through setting screws causes teeth to interlock; and as spring tensions, a *predetermined amount of pressure* is transferred to face of glass through the metal contact of face piece. In this way pressure is cushioned and distributed evenly. The spring also absorbs shocks, vibrations and pressures from expansion and contraction in the glass itself, results impossible to obtain except through definite pressure distribution and control.

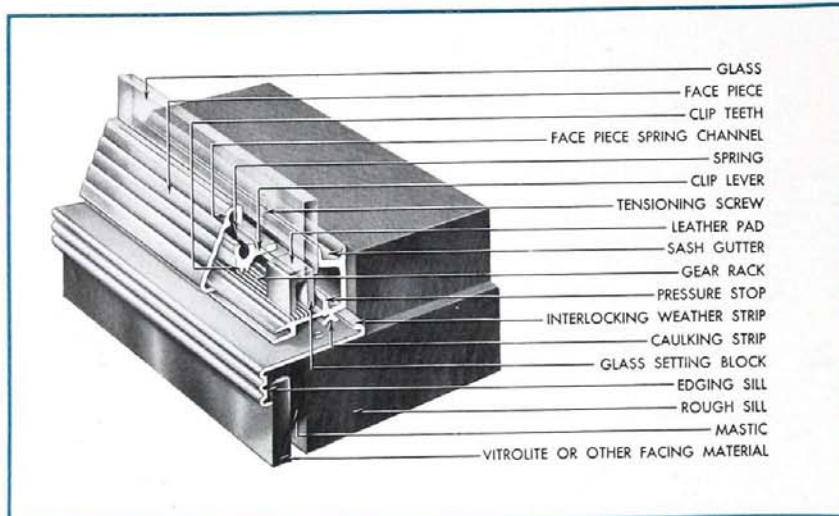

**300** Similar to Extrudalite 500 Series in construction and in operating principle. Chief difference between the two is the smaller size of the 300 Series which provides a narrower reveal. In both sash interlocking weather strips and caulking strips to break capillary action at the sill assure absolute weathertightness. Because of this, Extrudalite sash contain no weep holes for drainage or for ventilation, both of which are of doubtful value in metal storefront construction. These sash are self-supporting and their rigid construction of extruded metal provides perfect alignment and a constant close contact of glass and metal. Edging sills are secured to rough construction by standard means of attachment which are completely concealed by the base piece containing gear rack.

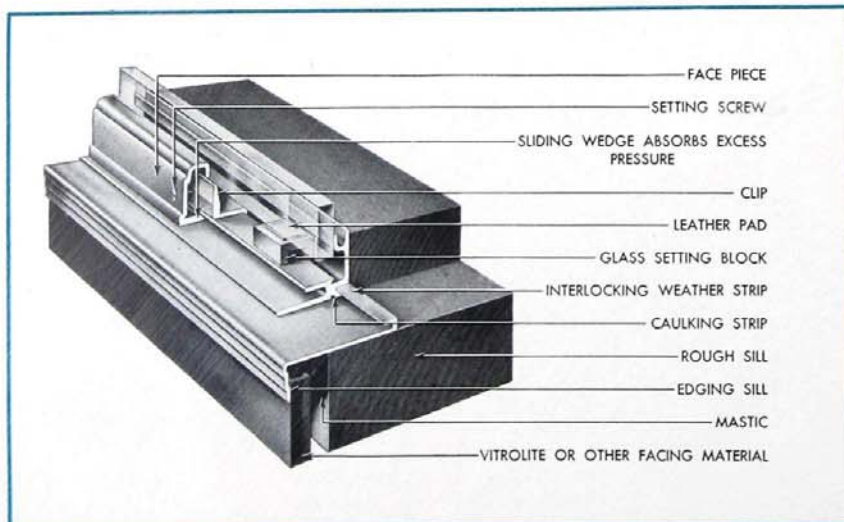

**100** A lightweight, economical sash providing a narrow reveal. It is self-supporting when used with the rigid clip or can be attached to a wood backstop by screws. In the self-supporting type, glass is held firmly by indirect pressure of face piece which is adjusted through a simple clip arrangement and operated by a face piece setting screw. Rigidity of extruded metal tends to distribute pressure evenly along glass. A tongue-and-groove at the bottom of the face piece acts as a sliding wedge to absorb excess pressure on the glass and allow a natural adjustment of the face piece according to glass thickness. This assures true alignment of glass and metal and thus eliminates unequal pressures or insufficient contact which might otherwise allow moisture seepage into sash construction.



Typical sections through Extrudalite construction show assemblies of the 500 Series and 300 Series with typical corner bar and division bar sections. With the 500 Series sash, at right, are shown exterior and interior corner assemblies that are adaptable to any type of Extrudalite construction and may be used with the 100 Series self-supporting sash as well as the spring-tension members. Each type of corner bar is designed so that glass may be set at both acute or obtuse as well as right angles. Pressure is cushioned and evenly distributed along the face of the glass, because of rigid alignment of extruded sections and is automatically adjusted by means of spring-tension nuts screwed to bolts concealed in the channel portion of bars at the interior face of construction.

In the center drawing is shown a typical division bar assembly in a section framed with a 300 Series sash. It is similar in holding principle and operating characteristics to the corner bars and is adapted for use with either of the Extrudalite spring-tension sash. These sections show assemblies which can be installed with equal facility in storefronts faced with structural glass, masonry of any sort, luminous areas or metal. They can also be employed in combination with various other Extrudalite members (see details that follow on pages 24 to 35, inclusive) designed to conform with them in appearances and operating characteristics.

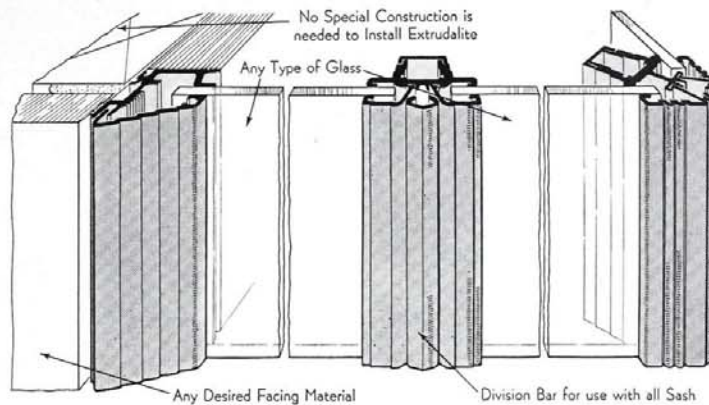
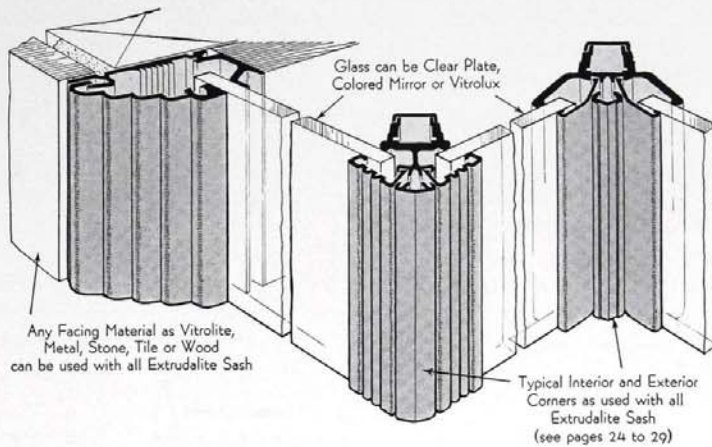

Inexpensive construction with Extrudalite Lightweight Sash — 100 Series — shows an extremely simple, practical and economical assembly of extruded members. This is self-supporting construction, showing typical glass division bars which are adaptable for use with the spring-tension Extrudalite sash if desired. They also find wide application in transom areas with half-sash of the 100 Series (see pages 28 and 29) and as holding members for luminous panels of Vitrolux or Blue Ridge Dif-fusing Glasses.

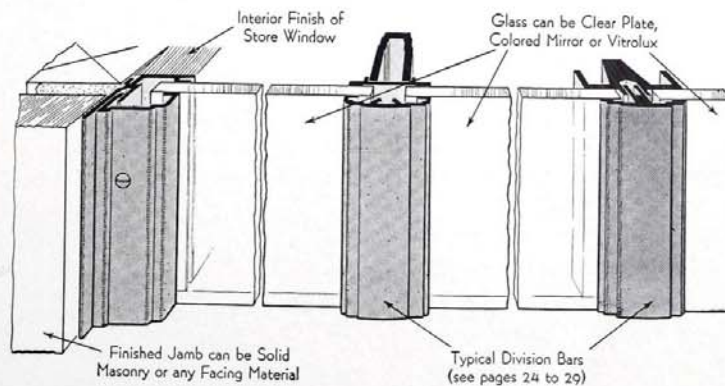



# HOW TO DESIGN WITH EXTRUDALITE

**M**ETAL construction with Extrudalite has an extremely wide application in modern building design. Members have been designed primarily for storefront construction. But their wide variety, their simplicity in appearance and principle of operation, their lightness and strength and the ease with which they can be installed immediately suggest a range of other uses. Extrudalite members can be used to form "picture windows" in residential work and, as trim, can hold many types of panels in residential, commercial and industrial interiors. Indeed, Extrudalite metal construction can be used in any type of interior or exterior installation to which its characteristics can contribute values in modern appearance, durability and ease of maintenance. The scope of Extrudalite application is limited only by the imagination of the designer. To aid him, the following pages show Extrudalite details which include, in each case, a basic standard with a number of commonly encountered alternates. Installation of Extrudalite follows commonly accepted practices. There exist no complications in using Extrudalite under any structural condition which would prove satisfactory for any other similar material.

**F**OR COMPLETE STOREFRONTS — The diagrammatic illustration below indicates how easily Extrudalite may be employed to solve every problem in the design and economical, up-to-date construction of a storefront. It is adaptable for use with any sort of storefront facing material. Being of rigid, extruded construction, it provides true alignment under all conditions of use. And Extrudalite can also be furnished in curved sections conforming to any radius of more than eighteen inches. The list of Extrudalite sections include: sash, vertical corner, reverse and division bars, transom bars, various types of edgings for sills and jambs, trim moldings, copings, soffit sections, hinged ventilators, pilaster coverings and show case doors as well as a complete line of extruded tubular doors, transoms and frames. Thus, through the Libbey.Owens.Ford organization, architect, builder or owner has at his command anything and everything in metal which finds a use in storefront design or construction. A study of the details on pages 24 to 35, inclusive, will indicate the ease with which Extrudalite may be used to produce strong, lightweight, easily assembled construction for every element of the modern storefront.

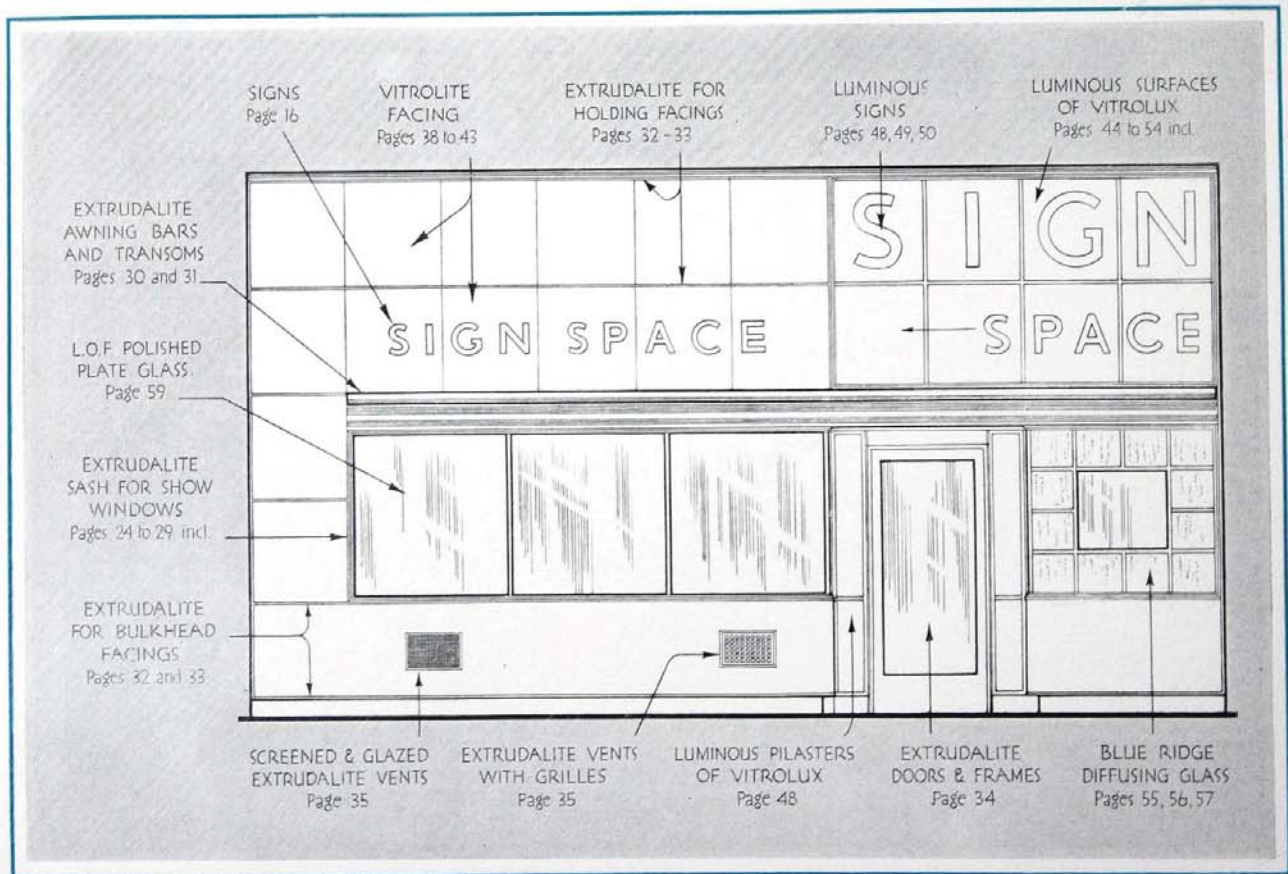



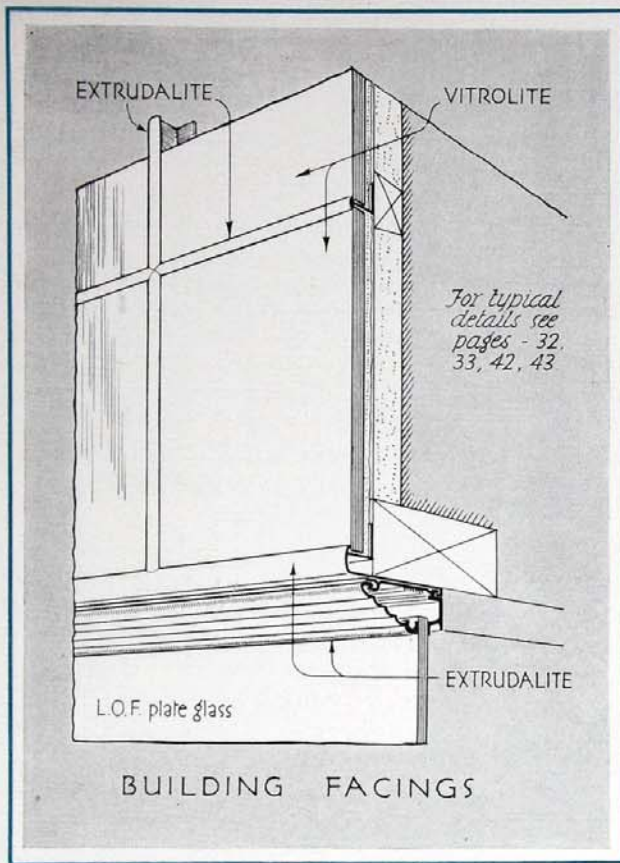

**FOR SECURING SOLID PANELS** — In appearance, strength and durability as well as in the simplicity of its sturdy construction, Extrudalite is well adapted as a holding system for a large number of materials commonly used to surface building facades. Illustrated here is a typical application which involves the use of Extrudalite sash and members to hold Vitrolite panels or any similar type of opaque structural glass. It is evident that the Vitrolite surfaces might be replaced by mirrors, metal of various kinds, by panels of plywood or any one of the many other surfacing materials of phenolic-resin or other synthetic compositions. Use of such holding members does not necessarily involve installation of Extrudalite sash as indicated in the sketch which is typical of any plain storefront facing above show window construction. This basic use of Extrudalite sections is practical for the exterior surfacing of any type of building. With or without various combinations of Extrudalite sash, sill edgings or transom members, the typical construction indicates a modern solution to the problem of finishing spandrel beams, facias or bulkhead surfaces commonly encountered in many sorts of commercial and industrial structures. Extrudalite can be similarly used on building interiors, the number of practical possibilities being limited only by the structural condition to which the designer must adhere. In all instances, installation presents no unusual complications.

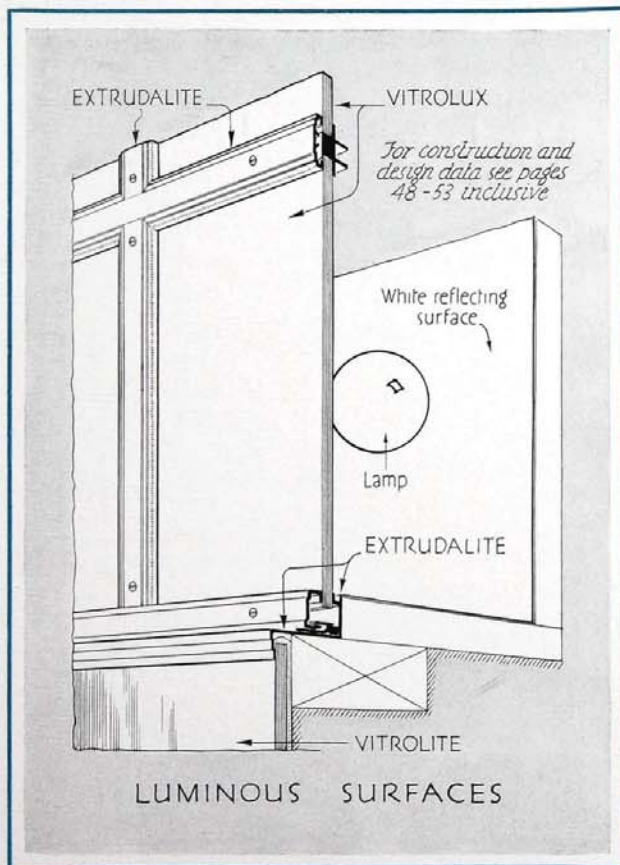

**TO FORM HOLLOW PANELS** — With the present easy availability of translucent materials, particularly those which, like Vitrolux, gives off luminous color when lighted from behind, architects have at hand a dramatic new element of design. But its use presents certain problems of construction. Required behind the luminous surface is adequate space for the installation and servicing of electrical equipment. Holding members which form panels of this sort must be strong but light in weight and in many instances must be so assembled as to permit removal of the luminous panel itself. Extrudalite can be used in a wide variety of such installations, one of which is illustrated at the left. Here a lightweight sash has been used with an arrangement of division bars which make it possible to remove a Vitrolux panel easily and quickly. This basic type of construction can be developed in a variety of ways by using different combinations of Extrudalite members as illustrated by details on the following pages. It is possible, for example, to set the luminous panel permanently in Extrudalite, with or without sash members, if structural conditions permit an access for servicing equipment from the inside. Several applications are illustrated in more detail in Part III of this manual on pages 48, 49 and 50 which contain details of Vitrolux installations. By addition of a few simple members, this application of Extrudalite can be used to form double-glazed areas as illustrated on page 55.



# SPRING-TENSION SASH 500 SERIES — HORIZONTAL SECTIONS

TYPICAL details shown on these two pages indicate use of the 500 Series Extrudalite Sash only under installation conditions most commonly encountered in practice. The character of the 500 Series design, the fact that sash members can be curved to any inside radius above 18 inches and the availability of many additional Extrudalite members that can be used with it, make this sash particularly adaptable to large storefronts in which unusually attractive design must be executed in a modern type of construction of highest quality. Extrudalite 500 Series Sash can be used with storefront facing materials of all types including metals and various kinds of synthetic panels or stone and marble veneers as well as Vitrolite, Vitrolux and other L.O.F. Glass Products.

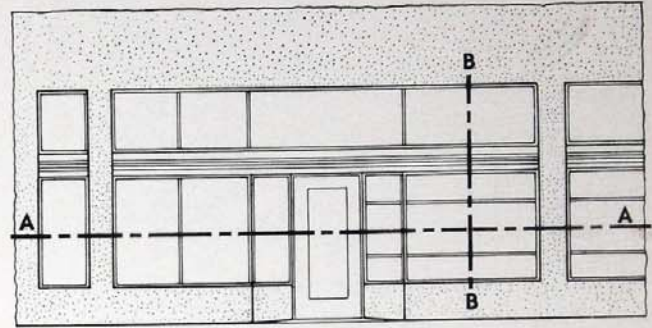

ELEVATION — TYPICAL STORE FRONT

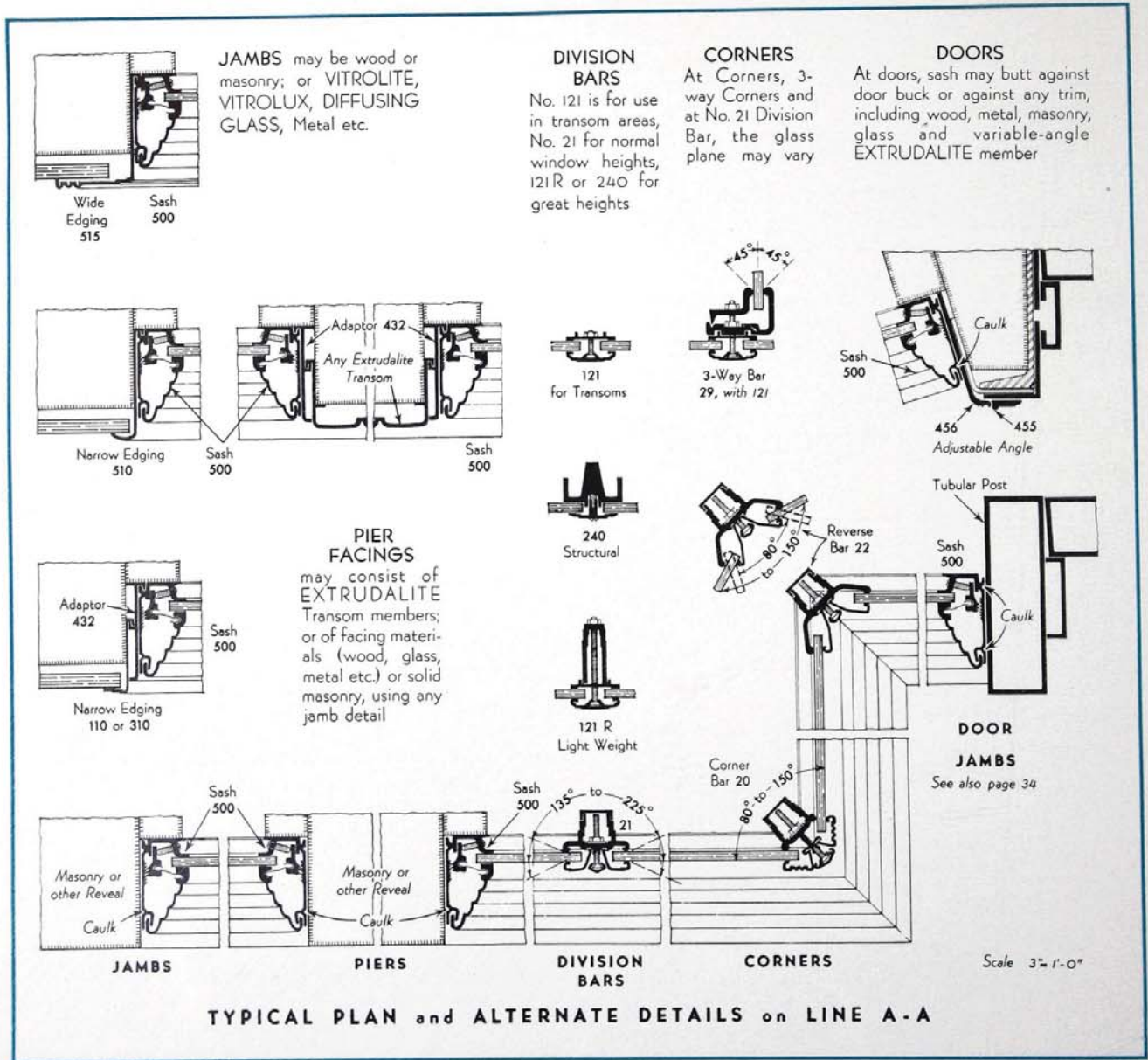



# SPRING-TENSION SASH 500 SERIES—VERTICAL SECTIONS

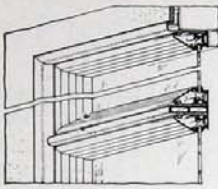

**ISOMETRIC VIEW**  
Intersection of Transom and Edging Strip

**BUILDING FACINGS**

Alternate details for use of EXTRUDALITE with VITROLITE, Metal etc. are shown on pages 32, 33 & 43. Additional details showing VITROLUX are contained on pages 48, 49 & 50; Mirrors, page 61

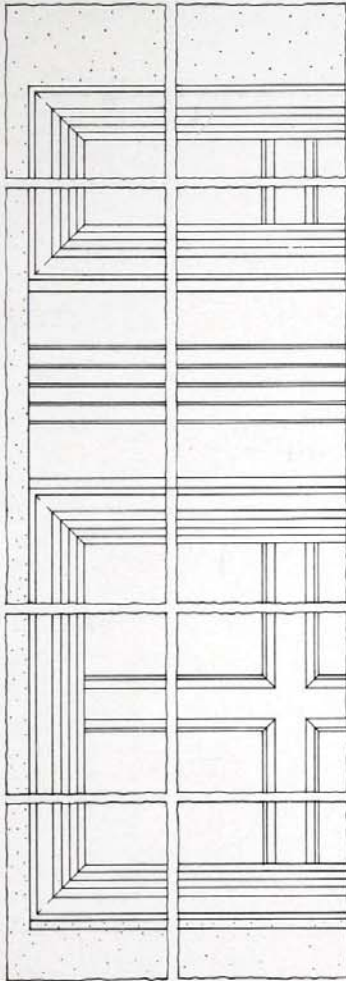
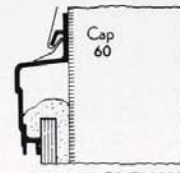

**ELEVATION - Masonry Reveal Shown**



**NO EDGING**

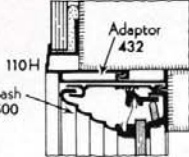

**NARROW EDGINGS**

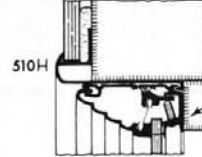

**ALTERNATE TRANSOM DETAILS**

Additional Extrudalite Transom and Awning Bars, and methods of forming transoms of other materials, are shown on pages 30 & 31

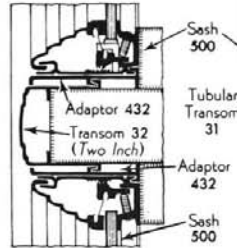
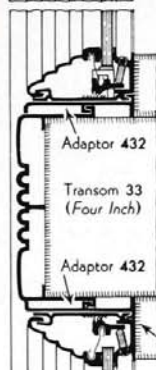

**DIVISION BARS**

Use Horizontal Bars No. 430 for excessive spans

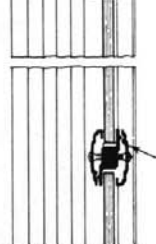
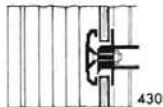

Horizontal Auxiliary Bar 30

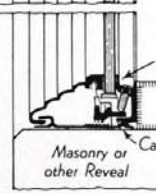

**WIDE EDGING**

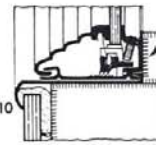
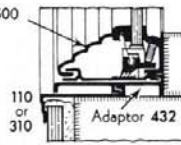

**ADDITIONAL BULKHEAD DETAILS**

showing the use of EXTRUDALITE with VITROLITE, VITROLUX, Metal and other facing materials, are shown on pages 32, 33 & 42

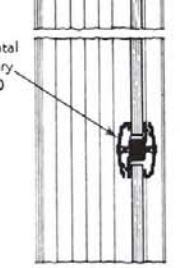
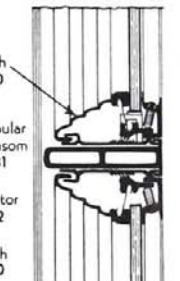
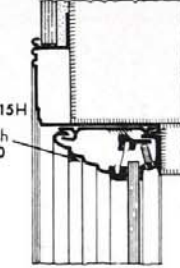

Horizontal Auxiliary Bar 30

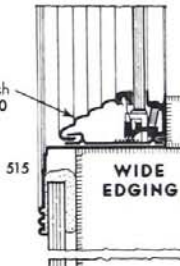

Division Strip 65

**REAR VIEW**  
Method of securing Division Bar No. 21, and intersection with 500 sash (300 similar)

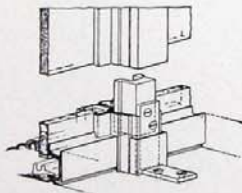

**TYPICAL SECTIONS and ALTERNATE DETAILS at B-B**

Scale 3"=1'-0"



# SPRING-TENSION SASH 300 SERIES—HORIZONTAL SECTIONS

**E**XTRUDALITE 300 SERIES SASH is similar in operating principle and basic construction to the 500 Series and can be used for generally similar storefront installations. Characterized by simplicity in design that produces a narrow window reveal, this sash can be used with the self-supporting member number 318 for openings with no supporting wood frame or without Extrudalite sills or joints when properly attached and caulked to adjacent masonry materials. When used with flat facing materials such as metal, synthetic marble or stone veneers, Vitrolite, Vitrolux, etc., the 300 Series Sash should be set with edging sills and jambs as indicated on these two pages. These details show typical installations under conditions most commonly met with in practice.

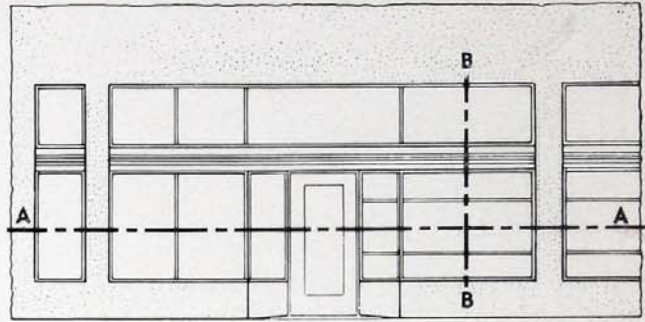

ELEVATION - TYPICAL STORE FRONT

Wide Edging  
15  
(515 for Deeper Reveal)

**JAMBS**  
may be solid masonry, wood, metal; or VITROLITE, VITROLUX, etc. held in EXTRUDALITE Edging Strips as shown

**DIVISION BARS**  
No. 121 is for use in transom areas, No. 21 for normal window heights, 121R or 240 for great heights

**CORNERS**  
At Corners, 3-way Corners and at No. 21 Division Bar, the glass plane may vary

**DOORS**  
At doors, sash may butt against door buck or against any trim, including wood, metal, masonry, glass and variable-angle EXTRUDALITE member

Narrow Edging  
110

121  
For Transoms

3-Way Corner  
29, with 121

Door  
Stop  
Sash 300  
Caulk  
456  
455

Narrow Edging  
310  
(510 for Deeper Reveal)

240  
Structural

Facings Nos. 455 and 456 are adjustable to varying angles

Caulk  
318  
Sash 300  
Self-supporting Jamb

**PIERS FACINGS**  
may consist of any EXTRUDALITE Transom, or of VITROLITE, VITROLUX, masonry, wood or other facing materials as used at jambs

121R  
Light Weight

Reverse Bar 22  
Sash 300  
Caulk  
Tubular Post  
**DOORS**  
See also page 34

JAMBS

PIERS

DIVISION BARS

CORNERS

**PLAN and ALTERNATE DETAILS at A-A**  
Scale 3/8" = 1'-0"



# SPRING-TENSION SASH 300 SERIES—VERTICAL SECTIONS

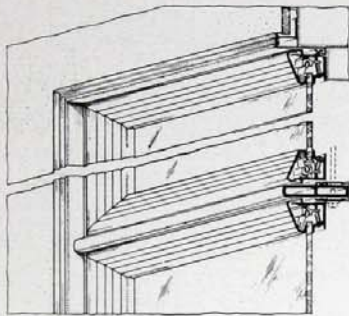

**ISOMETRIC VIEW**  
showing intersection of transom  
and typical narrow edging. Use  
hangers for long spans

**BUILDING FACINGS**  
Alternate details for VITROLITE  
are on pages 32, 33, & 43;  
VITROLUX on pages 48, 49,  
& 50; Mirrors, page 61

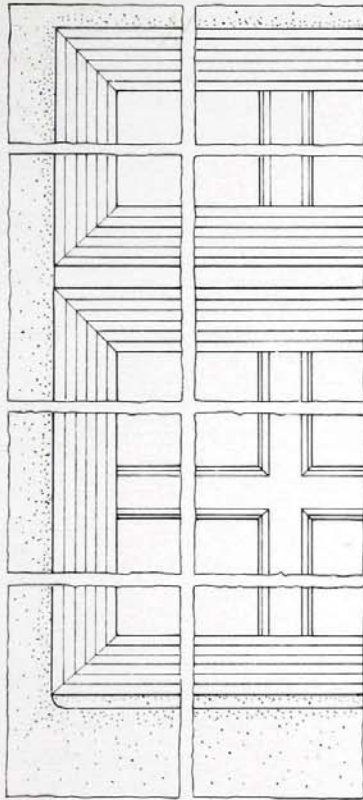
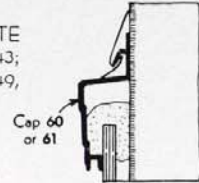

**ELEVATION - Masonry Reveal**

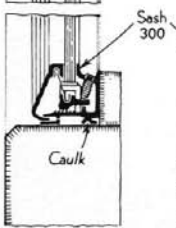
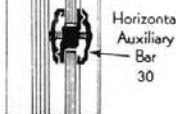
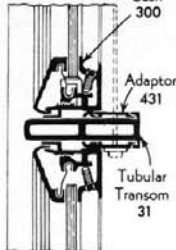
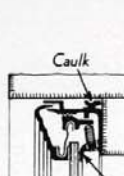

**NO  
EDGING**

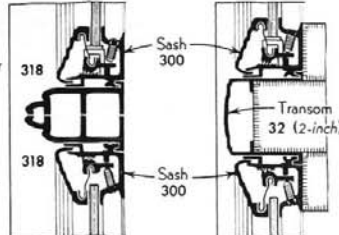
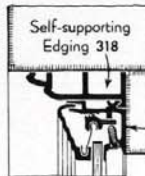

**STRUCTURAL  
HORIZONTAL  
BAR**  
is shown on page 25

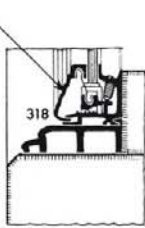

**SELF-SUPPORTING  
EDGING**

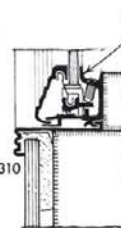
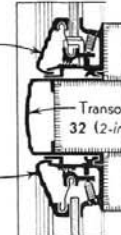
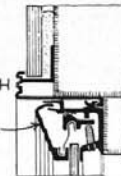

**NARROW EDGINGS**

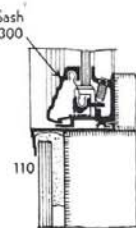
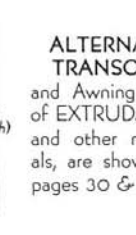
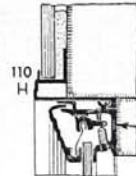

**ALTERNATE  
TRANSOMS**  
and Awning Bars,  
of EXTRUDALITE  
and other materials,  
are shown on  
pages 30 & 31

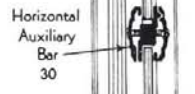
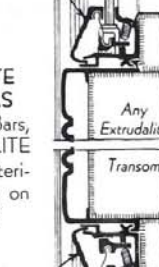
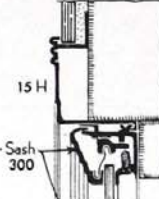

**WIDE  
EDGING**

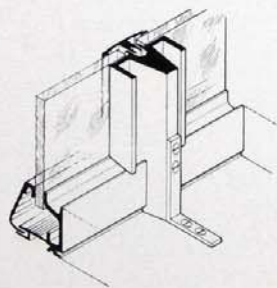
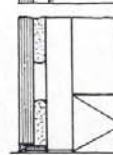
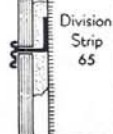

**REAR VIEW**  
showing attachment of Structural  
Division Bar No. 240

**ADDITIONAL BULKHEAD  
DETAILS**  
are shown on pages 32, 33 & 42

**TYPICAL DETAILS at SECTION B-B**

Scale 3"=1'-0"



# LIGHTWEIGHT SASH 100 SERIES—HORIZONTAL SECTIONS

THESE pages indicate use of the 100 Series Extrudalite Sash for storefronts in which advantages of extruded metal construction can be gained only through economies of installation. Sash 101 and Sash 102 are both self-supporting. The latter is double-faced and therefore is particularly adapted for development of "picture windows" or glass partitions. Sash 100 is not self-supporting and is installed with screws against a wood stop. Sash 50 should never be installed at the bottom of glass, but is useful as a framing member for light interior installation. Details here indicate possibilities of adapting the 100 Series, particularly to a wide range of inexpensive storefront uses. Corner and division bars can be used interchangeably with all three types of Extrudalite Sash.

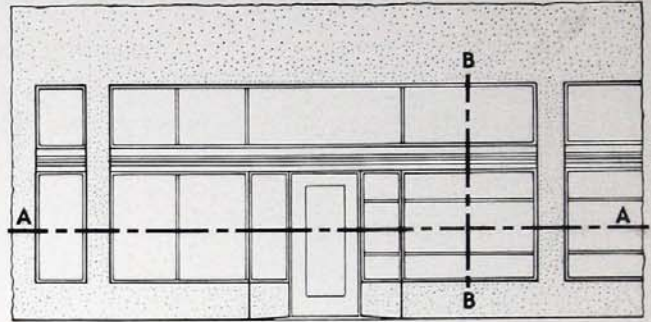

ELEVATION - TYPICAL STORE FRONT

**ALTERNATE JAMB DETAILS**  
are shown below and at right. Jamb reveals may be of solid masonry, wood, or VITROLITE, VITROLUX, etc.

Masonry Jamb 117

Narrow Edging 110

Narrow Edging 310

Wide Edging 15

**PIER FACINGS**  
may consist of any EXTRUDALITE Transom, or of VITROLITE, VITROLUX, masonry, wood, or other facing materials as used at jambs

Self-supporting Jamb No. 318

Inexpensive Window

**DOORS**  
See also page 34

Door jamb facings Nos. 455 and 456 are adjustable to varying angles

**JAMBS**      **PIERS**      **DIVISION BARS**      **CORNERS**

See page 24 for proper uses for Division Bars

Glass angle may vary in sections 20, 21, 22, 29, as noted

Scale 3/4" = 1'-0"



# LIGHTWEIGHT SASH 100 SERIES—VERTICAL SECTIONS

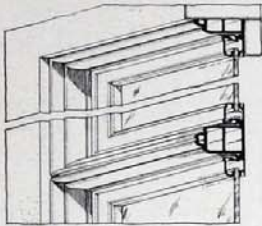

**ISOMETRIC VIEW**  
Transom and self-supporting Edging No. 318

**BUILDING FACINGS**

Alternate details for EXTRUDALITE with VITROLITE are shown on pages 32, 33 & 43. VITROLUX details are shown on 48, 49 & 50; Mirrors on page 61

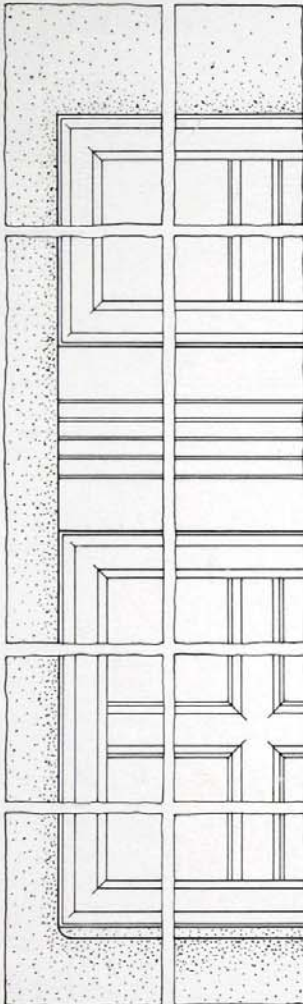
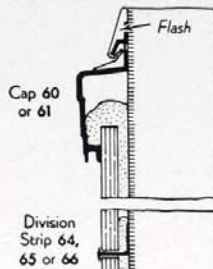

**ELEVATION - Masonry Reveal**

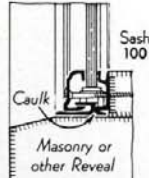
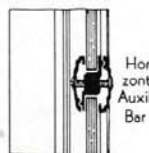
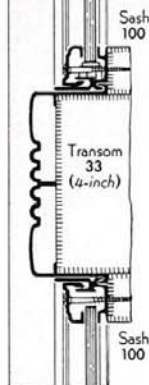
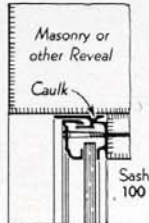

**NO EDGING**

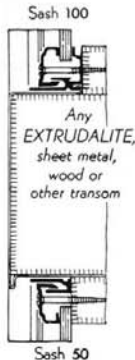
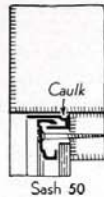

**SASH 50** (with 100) is intended for low-cost new or remodeling work

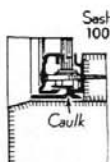

**INEXPENSIVE WINDOW - NO EDGING**

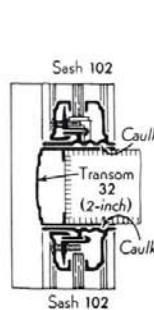
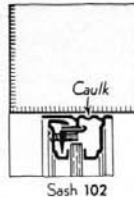

**SASH 102** is intended for use when show window interior finish is on same plane as reveal finish

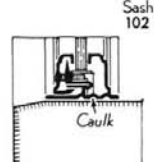

**DOUBLE FACE SASH - NO EDGING**

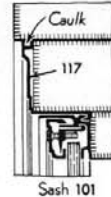

**ALTERNATE TRANSOMS**  
Additional Transom and Awning Bars of EXTRUDALITE and other materials are shown on pages 30 & 31

**SASH 101** should be used when sash can not be secured directly to interior finish

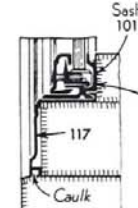

**MASONRY SILL**

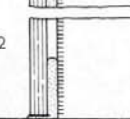
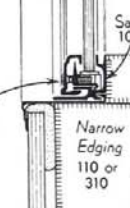
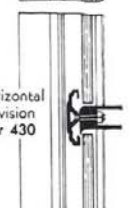
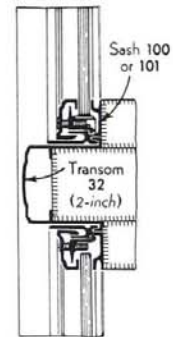
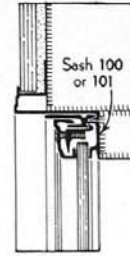

**ADDITIONAL BULKHEAD DETAILS**

are shown on pages 32, 33 & 42

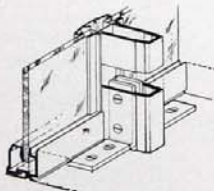

**REAR VIEW**  
showing attachment of Lightweight Division Bar No. 121R

**TYPICAL DETAILS at SECTION B-B**

Scale 3"=1'-0"



# TRANSOMS AND AWNING BARS FOR ALL EXTRUDALITE SASH

**E**XTRUDALITE Transom Members are interchangeable for use with Series 100, 300 and 500 Sash, although a Series 500 installation requires use of adaptor Number 432 in certain cases as indicated in details. Transom members can be used as a facing for jambs and bulkheads if desired and can be built to any size by employing filler units Numbers 38 and 39. Sash can also be installed with transoms of metal, wood, synthetic marble or stone veneers and any one of the various L.O.F. glass products. Details on page 31 are typical of standard Extrudalite Awning Hood installations. Either of the two types can be installed with Extrudalite transom members or, by using suitable edging members and adaptors, with any other type of transom in connection with any series of Extrudalite sash.

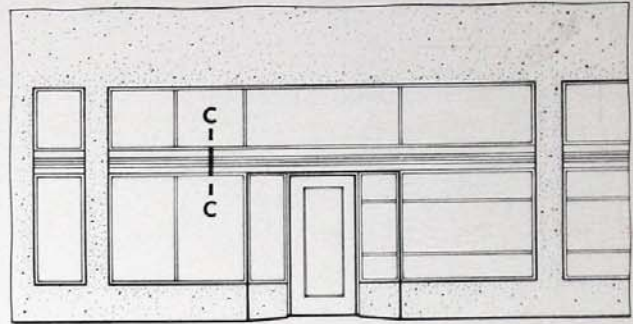

ELEVATION - TYPICAL STORE FRONT

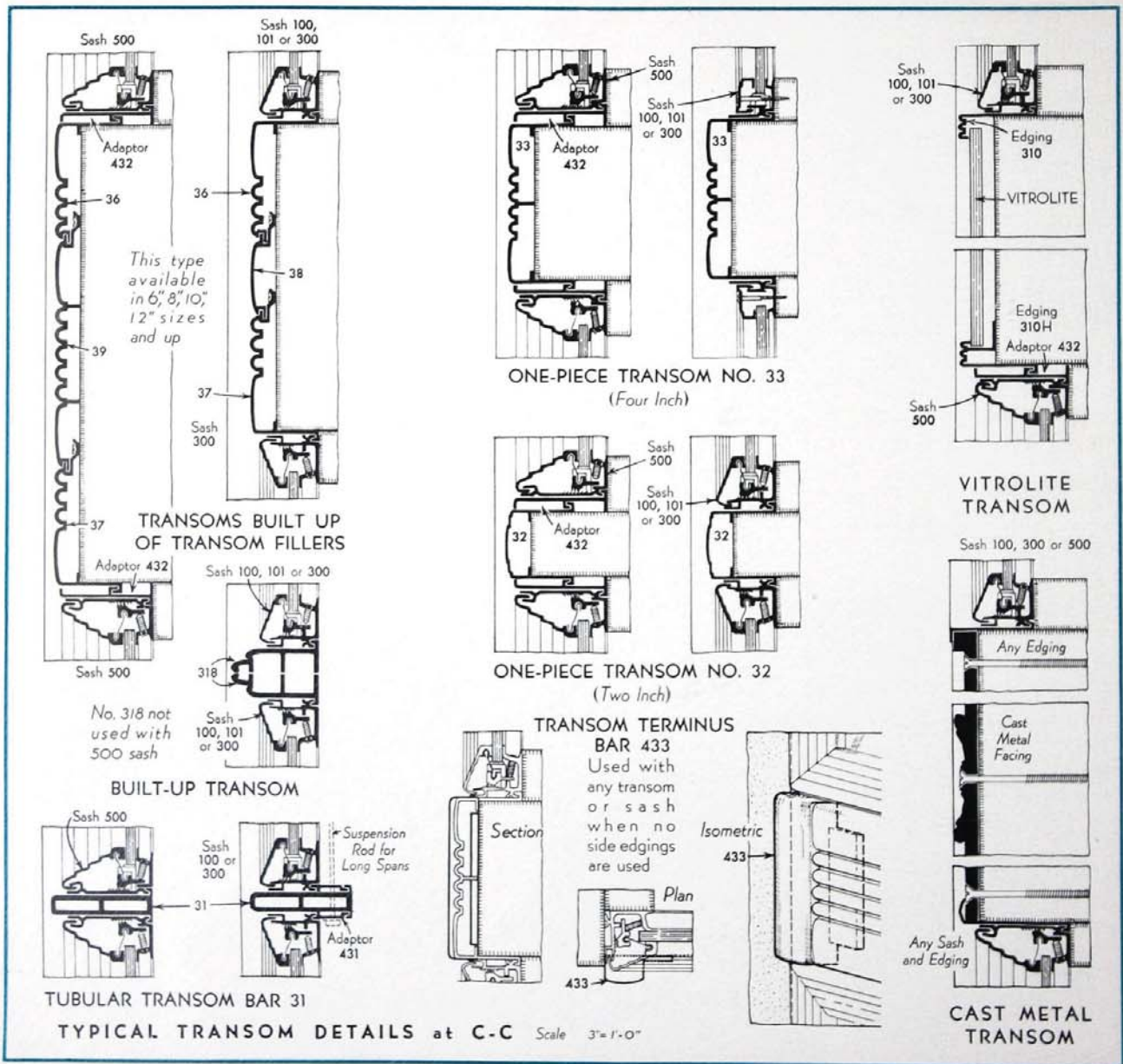



# TRANSOMS AND AWNING BARS FOR ALL EXTRUDALITE SASH

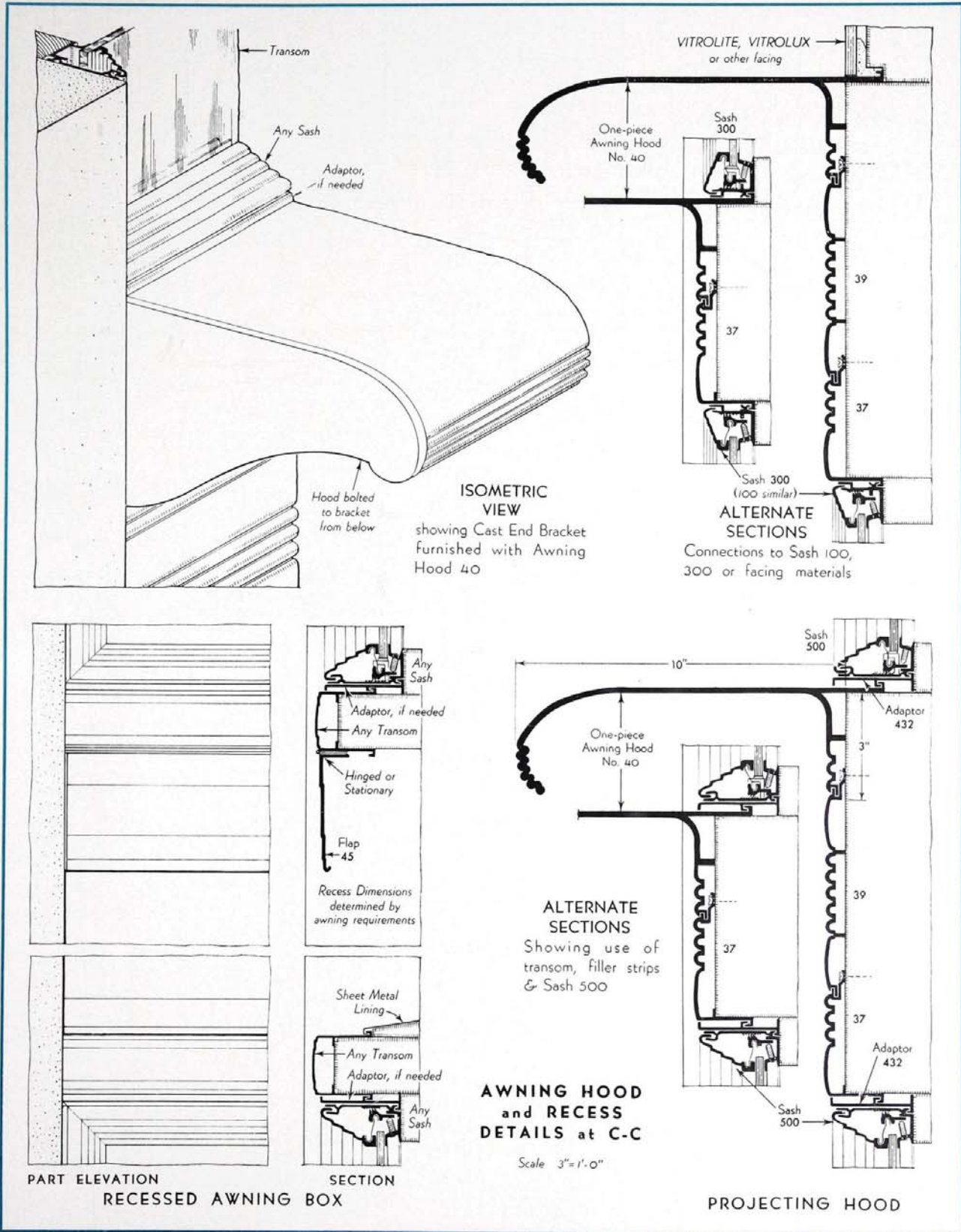



# BULKHEADS AND FACINGS OF EXTRUDALITE

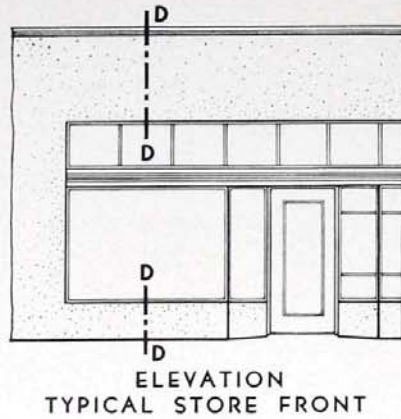

**F**OR securing all types of facing materials commonly used to surface storefronts in connection with show window construction, Extrudalite Edgings, Division Strips and Caps are available. The wide range of standard members is sufficient to meet all practical conditions, the most typical of which are detailed on these pages.

These holding members are manufactured in series which include edgings, division strips and caps. Each series is sized and designed for normal employment with a particular series of Extrudalite sash, although they are interchangeable to a certain extent. For example, Edging 515, designed primarily for use with the 300 Series sash, can be used with the 100 Series sash to produce an unusually deep reveal for this sash. Edgings are also suitable for use as caps.

Details at 3-inch scale on these two pages show Extrudalite holding members only in the most commonly encountered type of installation. Large scale details on this page suggest the wide range of facing materials that can be used successfully on storefronts when Extrudalite construction is employed. These details are merely typical of usual installations. They do not attempt to show the extremely varied possibilities for storefront surfacing through use of many types of sheet materials and Extrudalite holding members.

Any series of Extrudalite sash and any series of Extrudalite holding member is adapted for use with surfacing units of wood, metal, synthetic marble or stone veneers or any one of the many L.O.F. glass products.

Because these materials can be installed alone or in any sort of combination with Extrudalite, the designer has available a practical means for developing any novel plan arrangement and facade treatment which will most fully meet the owner's requirements.

**VITROLITE OR GLASS FACING**  
For additional details on VITROLITE see pages 40 & 41; VITROLUX, pages 48, 49, 50; Blue Ridge Diffusing Glass, page 55; Mirrors, 61

**VITROLITE AND METAL**  
in alternating panels, strips or other designs  
These details are adaptable also to combinations of Diffusing Glass, translucent marble, etc. and metal panels

**METAL FACING**  
Metal facings require a backing of rigid or semi-rigid board (such as fibre-board, plywood, etc.) to provide stiffness, and reduce resonance

**MASONRY FACING**  
Solid or Veneered

**FACINGS**

**GLASS AREAS**  
See notes on page 33

**BULKHEADS**

**TYPICAL SECTION  
D-D - 100 or 300 Sash**  
See also page 33  
Scale 3"=1'-0"



# BULKHEADS AND FACINGS OF EXTRUDALITE

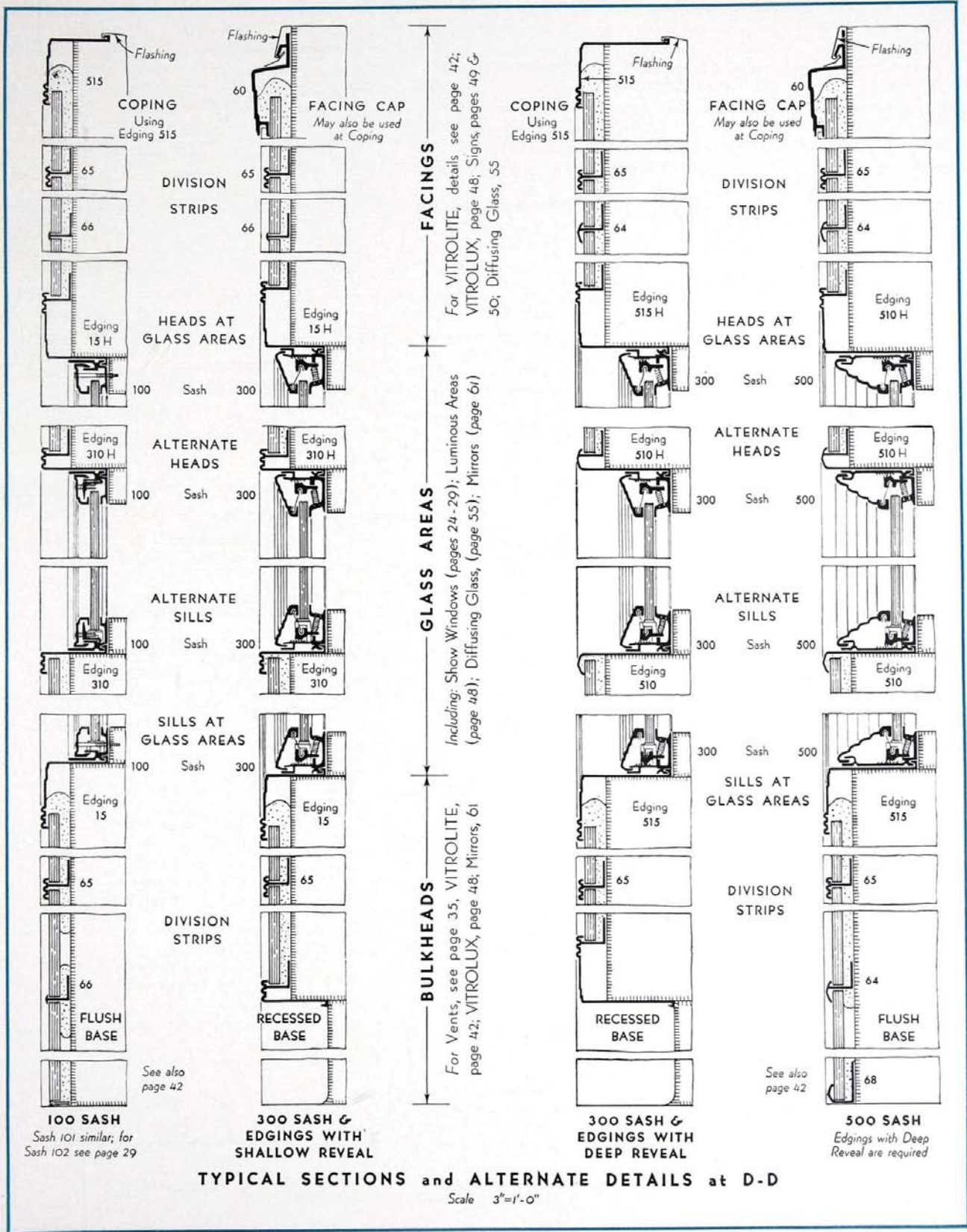



# TUBULAR METAL DOORS OF EXTRUDALITE

AVAILABILITY of tubular metal doors in a wide range of stock sizes as well as showcase doors and ventilators makes possible the complete development of any storefront with the Extrudalite system of metal construction. Details on this sheet are typical of Extrudalite doors and show commonly met installation conditions. They also suggest the wide possibilities for unusual design that can be developed by combining Extrudalite doors, stock metal shapes, Extrudalite sash and accessory members with L.O.F. glass products. Extrudalite frames, thresholds and jamb accessories (numbers 455 and 456) can be assembled in a variety of ways to meet every requirement. Sizes of doors, transoms and frames may be varied according to job conditions, except for the elements dimensioned on these details.

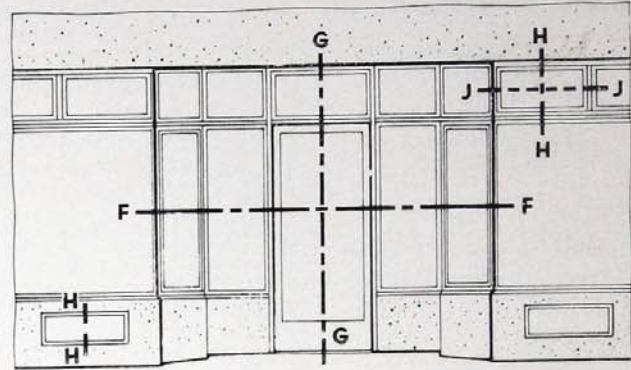

ELEVATION - TYPICAL DOOR AND VENTS

**TYPICAL SECTION G-G  
DOOR and TRANSOM**  
Doors Available Single or Double-acting

**ALTERNATE HEAD DETAILS  
Section G-G**

**ALTERNATE DETAILS  
at JAMB - Plan F-F**

**DOOR SIZES**  
Door, transom and frame sizes may be varied to suit job conditions, except those elements for which fixed sizes are given in these details

*All Details at Scale of 3"=1'-0"*



# SHOWCASE DOORS AND VENTS OF EXTRUDALITE

SHOWCASE door and ventilator assemblies can be used with all Extrudalite sash, horizontal and vertical division bars and corner bars for interior or exterior installation. Details are for typical exterior conditions. Showcase door details show practical construction for plan sections F-F noted on the elevation on the opposite page.

For openings greater than 34" use two showcase doors within a single frame. Ventilator details are of typical bulkhead construction at H-H and of typical transom construction at J-J. Dimensions at the right list stock sizes of light transom ventilator units. Appropriate bulkhead details are shown on pages 32 and 33.

## DIMENSIONS

w	h	H
26	16	30
20	16	36
20	16	42
20	16	48
20	16	60
24	20	48
24	24	60
18	12	24

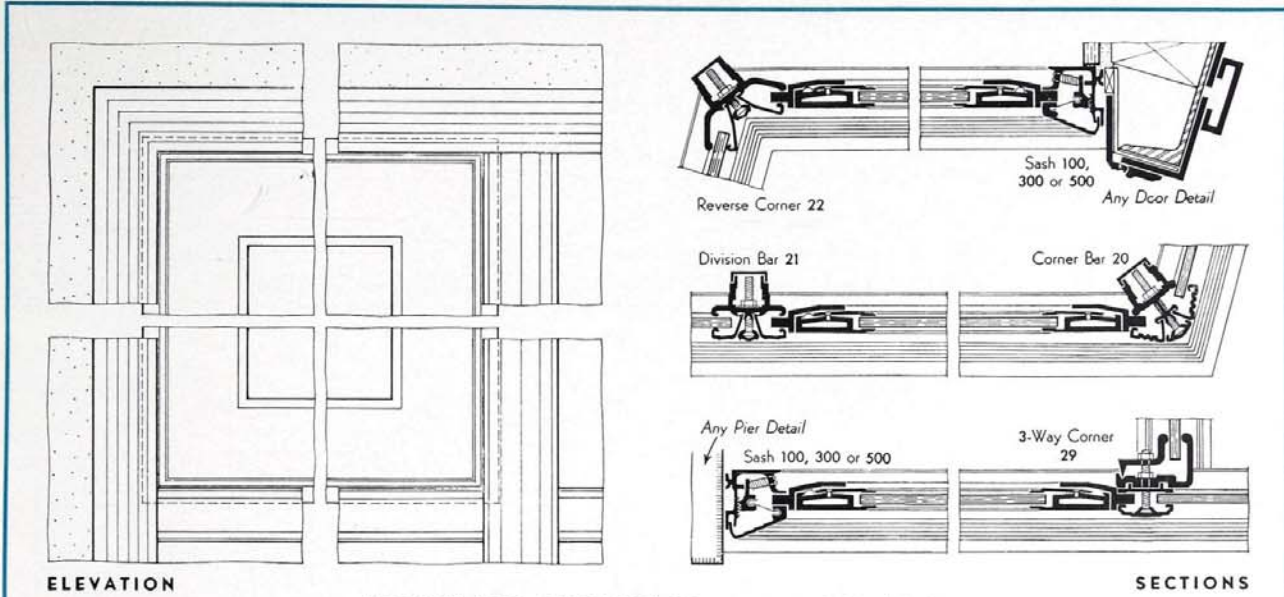
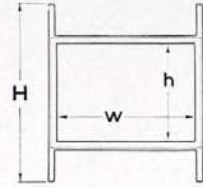

## ALTERNATE SHOWCASE DOOR DETAILS

Vents and showcase doors are interchangeable in sash and vertical or horizontal EXTRUDALITE members

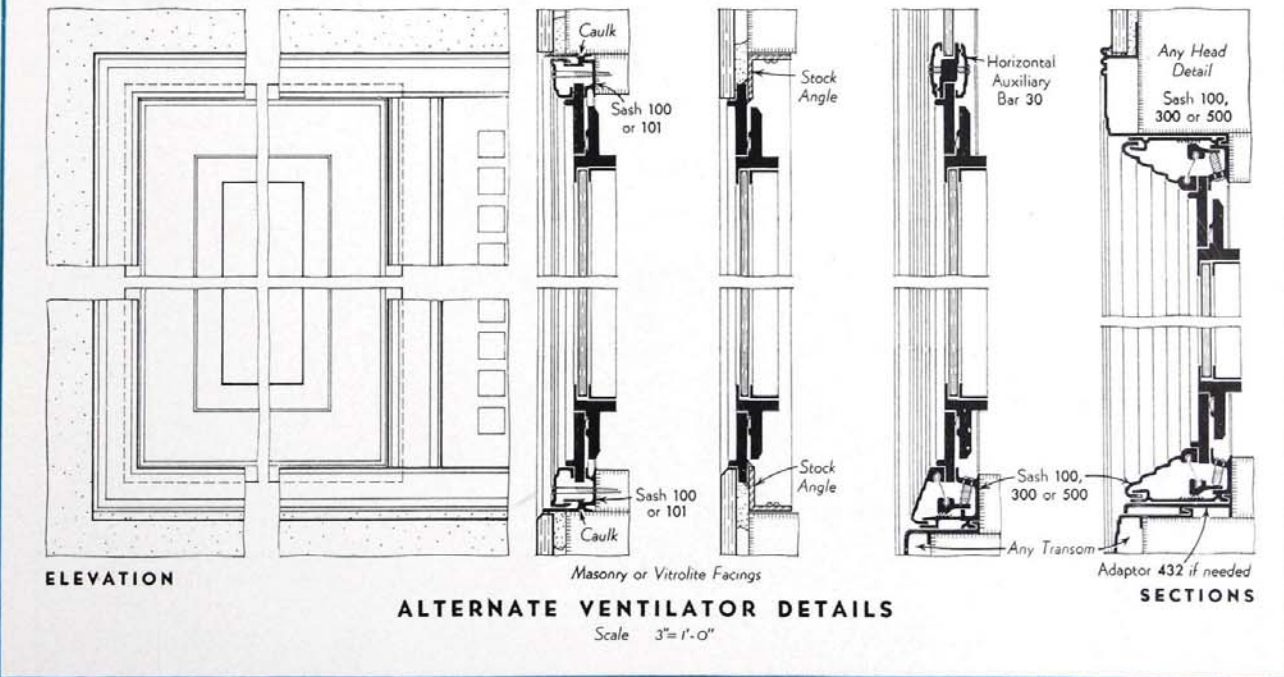

## ALTERNATE VENTILATOR DETAILS

Scale 3"=1'-0"



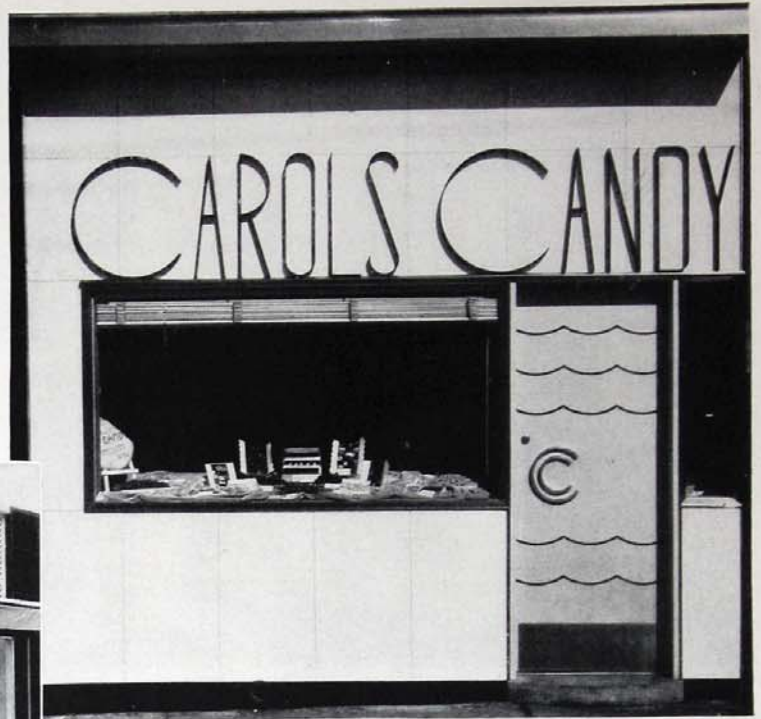
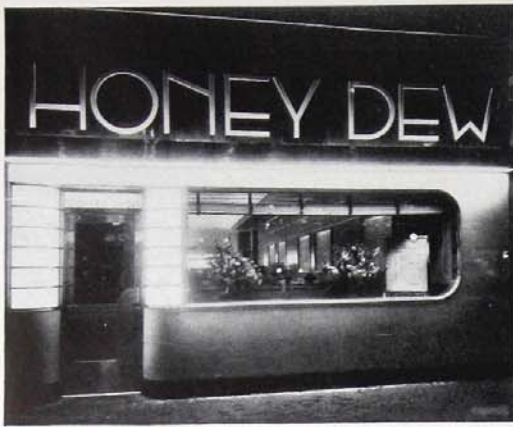

### VARIETY IN FORM, PATTERN AND COLOR

SUGGESTED here are a few of the almost limitless opportunities for strikingly original storefront design which colorful glass products offer to owner and architect alike. Today glass can be clear, opaque or translucent and colorful or not at the whim of a designer. It reflects, transmits, obscures or diffuses light. It is tough, durable, strong and can be made unbelievably resistant to shock and temperature changes. In all its various forms, colors and finishes modern glass, held permanently in place with light but strong members of extruded metal, can meet the most exacting demands which spring from the creative imagination of a storefront designer.



# PART THREE — L. O. F. GLASS PRODUCTS

Ideal materials for modern storefronts should combine strength and durability with a colorful and attractively fresh appearance. In addition they must be easy to install and economical to maintain. Of all modern materials glass measures up most completely to these standards.



**E**VERY type of glass product needed for development of attractive, up-to-date storefronts is manufactured by Libbey-Owens-Ford. Briefly

described here, these modern building materials, with Extrudalite, comprise the most completely coordinated group of storefront products available to owners, builders and architects.

**VITROLITE** is an opaque, structural glass particularly appropriate for the facing of bulkheads, store facades above the show windows and for trim around doors, windows or grille openings. It is equally adaptable for interior or exterior use and is furnished in sheets of various sizes and thicknesses which are easily applied with mastic or metal moldings. Because of its opacity, Vitrolite is not adapted to development of luminous surfaces. But it can be successfully flood-lighted to gain night-time advantage of a wide range of solid and agate colors. Vitrolite is susceptible to a variety of surface finishes and may be inlaid, cut or ground.

**VITROLUX** is a color-fused tempered plate glass which, like Tuf-flex, has unusually high strength and extraordinary resistance to thermal shocks. It is opaque or translucent depending upon the amount of color applied during manufacture. Translucent Vitrolux diffuses light so well that lamps may be placed close behind it without producing an effect of spottiness. It is not harmed by heat from the lamps or by the contrasting cold of rain or snow to which exterior installations are subject. These characteristics combine to make Vitrolux a surfacing material particularly adapted to formation of luminous areas in which both light and color play important parts. Colors of Vitrolux are available to match most solid colors of Vitrolite so that the two materials can be safely employed side by side on the same storefront. In addition, Vitrolux is available in a wide range of

other shades. This glass product cannot be etched, drilled, ground or cut after manufacture and must therefore be accurately detailed before manufacture.

**BLUE RIDGE FIGURED GLASSES** are available in a wide range of surface patterns which vary in relative obscurity and light diffusing quality. Most of them are available as wired glass when increased strength is desired. They are adapted to both exterior and interior uses and because of their decorative appearance and controlled diffusion properties find wide application on storefronts of any type in transom and bulkhead areas, as light diffusing panels and as show window backings.

**AKLO GLASS** is a product of special composition which absorbs the infra-red rays of the sun and consequently lessens transmission of solar heat. It can be effectively used in place of the usual plate glass in windows of florists' and ladies' apparel shops, candy stores, bakeries, etc., which display products susceptible to damage or deterioration through exposure to solar heat. Aklo looks like standard L.O.F. Plate Glass, though it transmits slightly less light.

**POLISHED PLATE GLASS** is a standard product of the building industry widely used in window areas of any practical size. Interior uses include such elements as screens, partitions, shelves, etc., and a wide range of decorative applications. L.O.F. Plate Glass is characterized by a high luster and freedom from imperfections. It is available clear or in several colors.

**MIRRORS** of polished plate glass may be clear or colored and backed with the conventional silvering or a metallic surface of copper, bronze, gunmetal, etc. Availability of large mirror sheets have made this glass product a practical building material well suited as a facing for bulkheads, spandrels and upper store facades, as a covering material for columns and pilasters and as trim for doors, windows or cased openings for both interiors and exteriors. Mirrors can be etched, ground, sandblasted or painted as desired.



# VITROLITE STRUCTURAL GLASS

**VITROLITE** is an opaque structural glass which has long been used in buildings of all types for a great variety of architectural and decorative purposes. Originally developed for use where highly sanitary finishes were required, its scope of use has been greatly broadened by the introduction of color variety and the development of new textures and decorative treatments. Its appearance and peculiar properties make Vitrolite significantly expressive of modern design, both interior and exterior. One of its most popular and successful applications in recent years has been found in the facing of storefronts.

**CHARACTERISTICS.** Vitrolite, like all structural glasses, is fused at high temperature. Its structure is dense and tough, with a tensile strength and resistance to wear greater than that of marble. The surface of Vitrolite has a high luster and the back is ribbed so that it may be effectively cemented to hard, dry, stable surfaces.

Vitrolite will not warp, swell or craze. It is impervious to all liquids in common use and is highly resistant to staining, marking or abrasion. It is easily cleaned by wiping with a damp cloth, or, in extreme cases, by washing with soap and water.

**PHYSICAL PROPERTIES.** Vitrolite has a minimum tensile strength of 937 pounds per square inch and crushing strength of 3,658 pounds per square inch, which is about 40% greater than that of marble. Its weight in pounds per square foot is given in the following table:

<i>Thickness (inches)</i>	<i>Net Weight</i>	<i>Packed Weight</i>
$\frac{3}{8}$	4	5
$\frac{7}{16}$	$5\frac{1}{4}$	$6\frac{1}{2}$
$\frac{3}{4}$	$9\frac{1}{2}$	12
1	11	14
$1\frac{1}{4}$	$14\frac{1}{2}$	18

**SURFACES.** Vitrolite is produced with two types of polished surface — fire-polished and mechanically polished. The fire-polished surface is a natural result of the melting, rolling and annealing processes during manufacture and is high, hard, smooth and dense. Modern manufacturing methods have made this surface remarkably free from defects and the waviness common to ordinary fire-polished surfaces. It is suitable for installation within a wide range of usual structural conditions.

Where mirror-like, reflective surfaces are desired Vitrolite in black and in several other colors can be supplied with a mechanically polished surface, at slightly higher cost.

**COLORS AND DECORATIVE TREATMENTS.** Vitrolite colors are shown in the chart on the opposite page, which reproduces the true colors as nearly as practical limitations of printing processes permit. Other colors than those shown may be obtained on special order on the advice of an L.O.F. technician. For accurate color selection ask for samples.

A wide variety of textures and ornamental treatments some of which are illustrated on the opposite page may be given Vitrolite. Plain or colored sandblasted ornament may be applied, or thin inlays of colored opaque glass or mirrors. A relief effect may be obtained by cementing Vitrolite letters to a Vitrolite background; a grill may be made by sandblasting through Vitrolite over a stencil. Surface effects may be obtained by various processes of glue-chipping and sandblasting over resists.

**SIZES AND THICKNESSES.** White, black, gray, jade and ivory are produced in the five thicknesses given in the table of weights. Agate colors and other plain colors are made in  $11/32$  inch thickness only.

For storefront work, the designer should limit the size of individual slabs to a gross area of six square feet with a maximum horizontal width of 3' and a maximum height in any one piece of 4'. For wainscoting, ashlar pieces from 8" x 12" to 24" x 24" are commonly used. Within these limits they are furnished with finished edges at a somewhat lower price than if especially cut and finished to fractional or irregular sizes. For complete interior and exterior applications consult Vitrolite literature.

**STOREFRONT WORK.** Vitrolite is recommended for the facing of all storefront and facade areas where an opaque decorative material is required which can withstand wear and abrasion, and requires a minimum of maintenance. It can be used harmoniously in conjunction with Vitrolux where parts of the store facade are to be made luminous at night, since the surface of translucent Vitrolux by day is similar in appearance to that of polished Vitrolite. Attachment to structural surfaces may be made by means of cements (see pages 40 and 41) or by the use of appropriate Extrudalite members, as shown in the drawings on pages 42 and 43 and the series of Extrudalite details on pages 24 to 35 inclusive.

**STRUCTURAL ORGANIZATIONS.** Franchised Vitrolite dealers, experienced and competent in the installation of Vitrolite, are located in all principal cities. They may be called upon for additional information and for estimates including, if desired, entire storefronts embracing Extrudalite as well as other Libbey-Owens-Ford glass products.





WHITE



BLACK SHADED SANDBLAST



GRAY



IVORY



ORCHID AGATE



ROYAL BLUE AGATE



YELLOW



JADE AGATE



SUN TAN



WALNUT AGATE



EMERALD AGATE



JADE

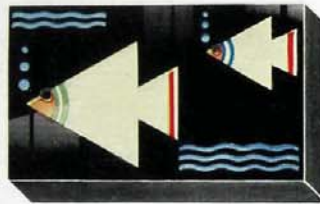

COLORS SANDBLAST OR INLAY

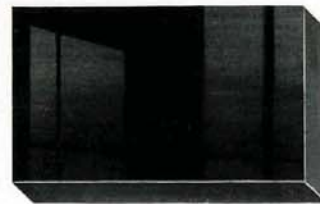

BLACK

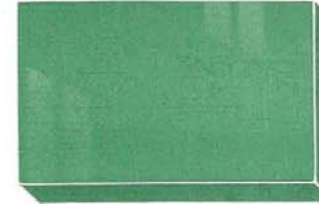

TROPIC GREEN



RED

STANDARD Vitrolite colors and principal decorative processes are illustrated on this page. Sun Tan, Black, Yellow, Tropic Green and Red are mechanically polished; others are fire-polished. Agate colors show consider-

able variety in veinings. Three of them — Emerald agate, Walnut agate and Royal Blue agate — are furnished in light, medium and dark shades. When ordering, specify shade desired. Medium shades are illustrated. Decorative proc-

esses include sandblasting, colored sandblast decoration, and inlaid decoration. Special finishes include Chipped, Crackle, Granite and Honed. Whenever color selection is an important factor, request Vitrolite samples.

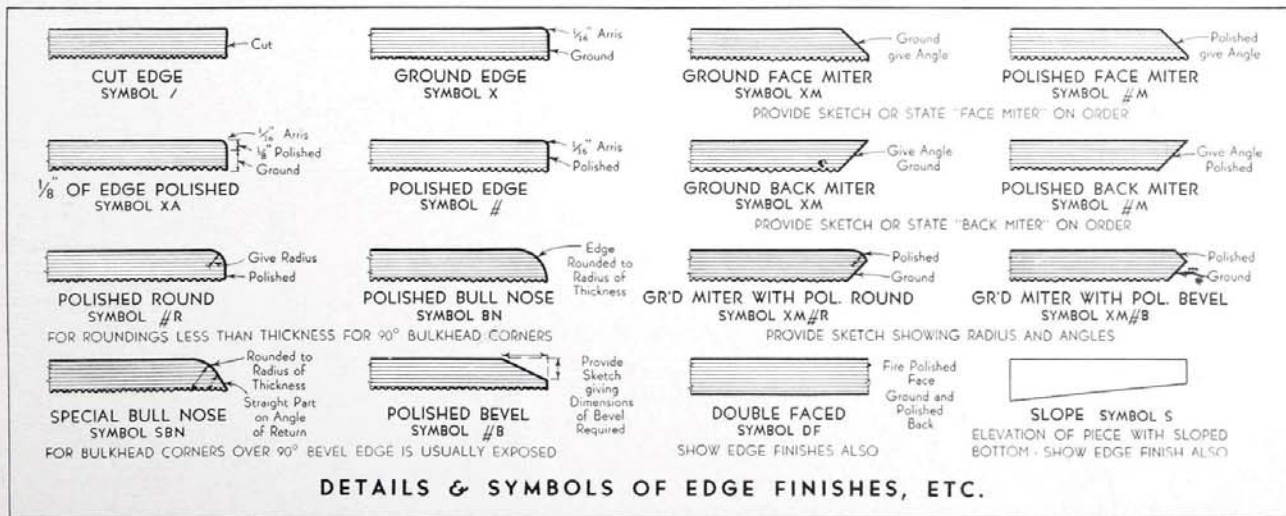



# BASIC CONSTRUCTION DATA

**S**UCCESSFUL use of Vitrolite requires structural methods and detailing which are definitely different from those employed in the application of marble or tile. The details and specifications on these and the following two pages show recommended practices that are based on years of successful experience in the use of Vitrolite for storefronts and other purposes. Careful study of these pages and the procedures indicated therein will reveal a considerable

difference in the methods of construction for exterior and interior applications of Vitrolite.

Because of the extremes of temperature to which it is exposed in exterior work, special precautions must be observed to safeguard Vitrolite, which has a very low coefficient of expansion, against the expansion or contraction of materials back of it or adjacent to it, such as metal, wood, concrete or masonry, all of which have considerably

higher coefficients of expansion. Vitrolite should never come in direct contact with any of these materials. It should either be held in Extrudalite members in accordance with typical details to be found in this section, or else space should always be left for clearance between the Vitrolite and the masonry or other structural supports. This space should be filled with joint cement, adhesive cork tape, caulking, or a combination of these, depending on location.

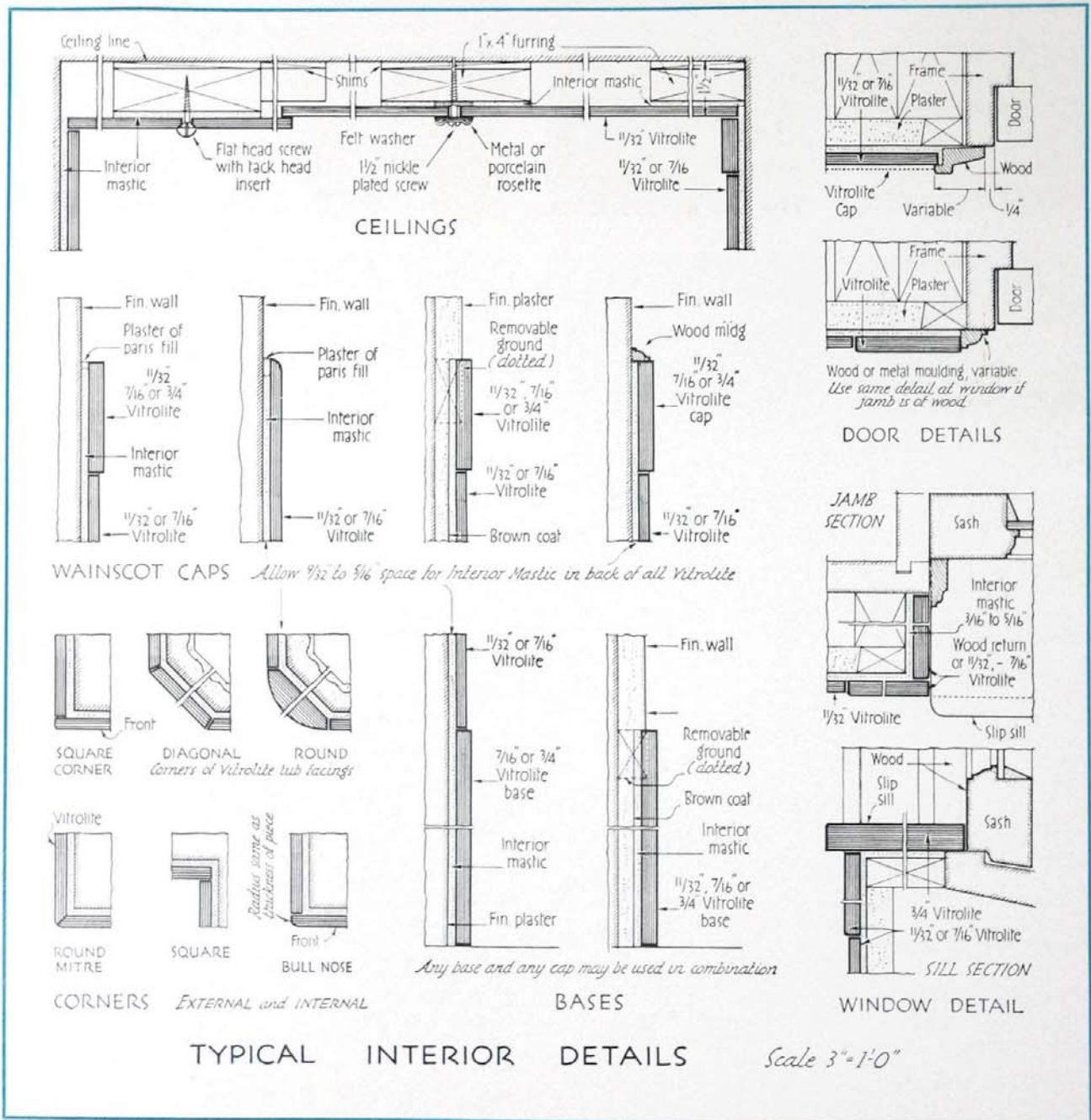



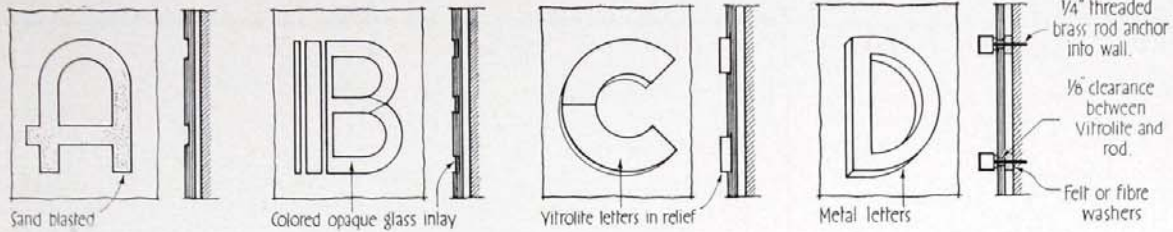

TYPES OF SIGN LETTERS Scale 1/2"=1'-0"

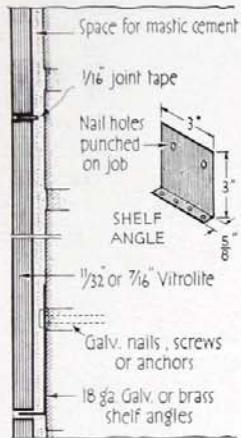

STANDARD CONSTRUCTION For Store Fronts

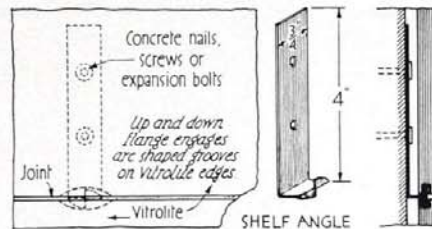
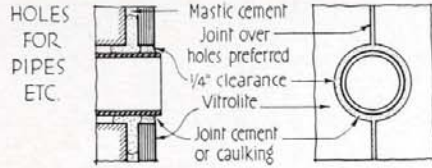

SYSTEM of MECHANICAL FASTENING For Upper Stories

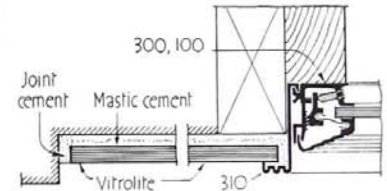
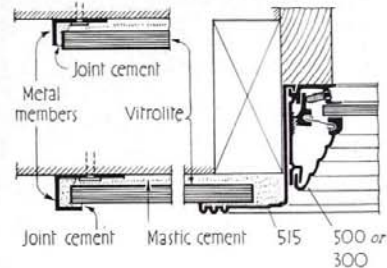

END FINISH ..... and JAMBS

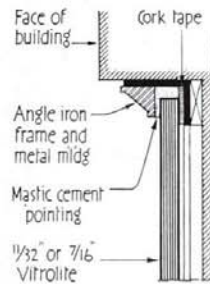
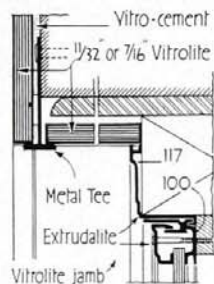
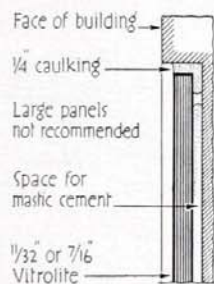

SECTIONS THRU SPANDRELS

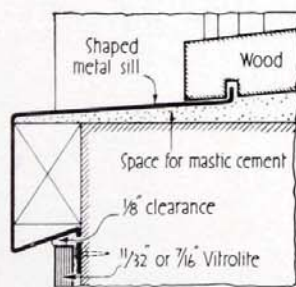
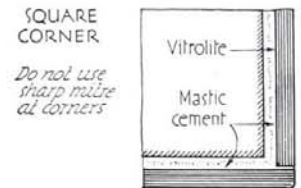
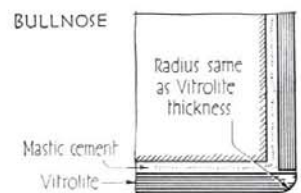

WINDOW SILLS

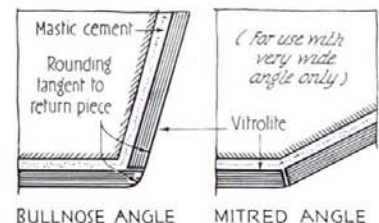
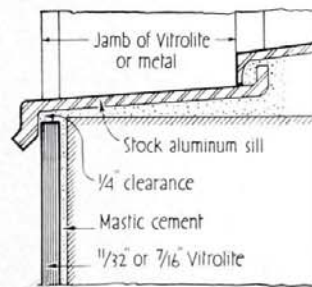

PLANS at CORNERS

TYPICAL EXTERIOR DETAILS Scale 3"=1'-0" unless otherwise noted.



# STOREFRONT CONSTRUCTION

TO SECURE Vitrolite on storefronts three installation methods are recommended. *First:* Cementing to a suitable backing using a mastic cement especially made for exteriors with shelf angles for supplementary support. *Second:* Mechanical attachment by means of metal ties secured to the wall and anchored to the Vitrolite in concealed grooves. *Third:* Framing with exposed metal members such as Extrudalite, using mastic cement as setting compound.

The first method is practical for store facades up to two stories in height. For higher structures the other methods should be specified. There exists no height limit when Vitrolite is supported by Extrudalite members.

Provision for normal expansion and contraction is a necessary element in every Vitrolite wall. Therefore use of excessively large pieces of Vitrolite should be avoided. A maximum practical size should not exceed 24" x 30" or 36" long for narrow strips laid horizontally. Cushioning should be provided at the sidewalk line, in joints and at all places of contact with other materials; and the use of mastic cement which retains a degree of elasticity is essential. Bulkhead facings should contain a base section about 6 inches high to provide an extra horizontal joint for expansion.

All abutting edges must be ground and have a small arris; all exposed edges must in addition be polished. Bullnose corners are recommended for bulkheads. Top edges should be protected with metal trim such as Extrudalite cap members especially designed for this purpose and flashed to assure watertightness.

Vitrolite can be installed against any firm, dry, rigid and permanently secure wall surface, although smooth masonry, concrete or cement plaster on metal lath are preferred. Never apply to wood or any other material that is subject to warping, swelling or dry rot. Walls should be straight and plumb; all loose surface coverings should be removed and the surface completely covered with a brushed-on coat of binding compound supplied for use with the mastic cement.

Mastic cement may be applied to the back of the Vitrolite slab, or to the backing, and should attain a 60% coverage in  $\frac{1}{4}$  to  $\frac{3}{8}$ " thickness. Wherever openings occur or Vitrolite abuts other materials, a complete seal extending under all edges is necessary.

Pointed joints (as distinguished from Extrudalite joints) should be as follows: Horizontal joints  $\frac{1}{8}$ " wide and buttered over cork joint-tape which is set back  $\frac{1}{8}$ " from face. Vertical joints  $\frac{1}{2}$ " wide ( $\frac{1}{8}$ " may be used if desired) and buttered.

## TYPICAL BULKHEAD FACINGS

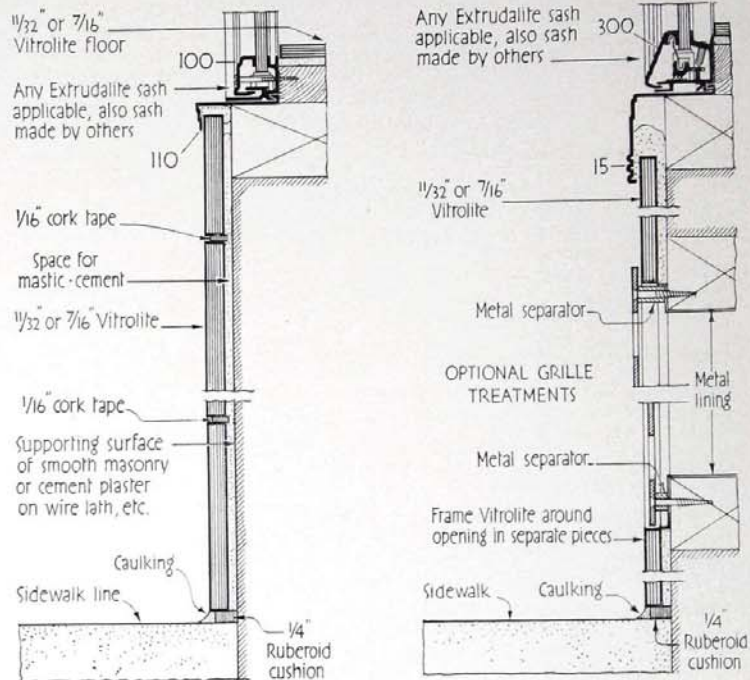

Scale 3" = 1'-0"

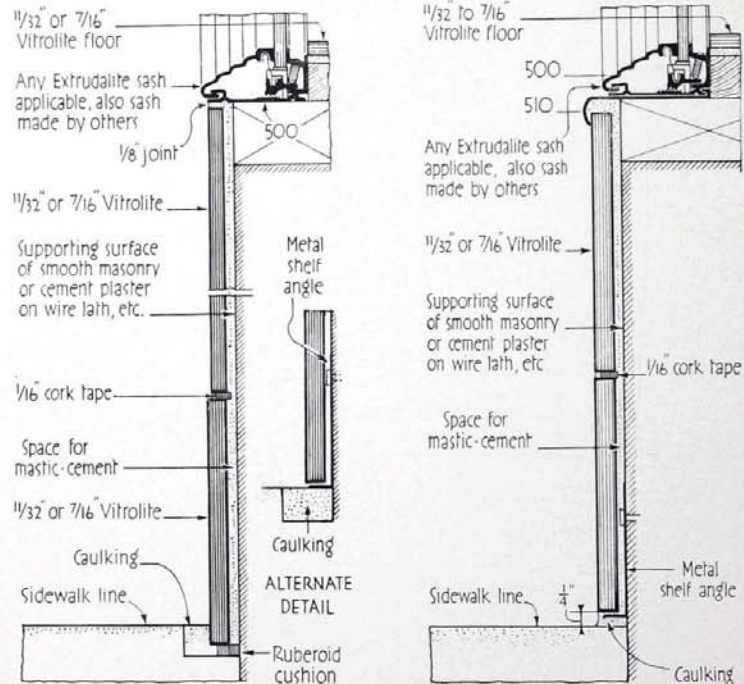

NOTE! Use of Extrudalite for installing Vitrolite is shown on pages 32 and 33



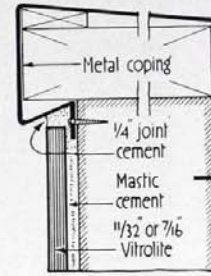
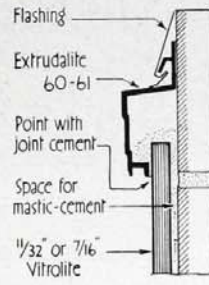
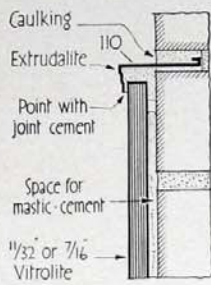
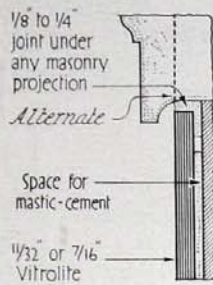

TYPICAL CAP DETAILS

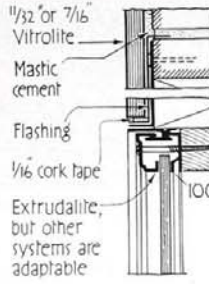
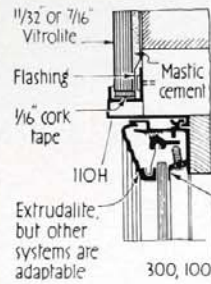
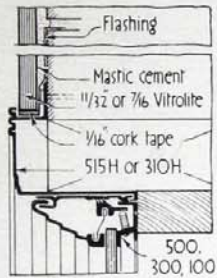

WINDOW HEAD INTERSECTIONS

## BUILDING FACINGS OVER SHOW WINDOWS

*Any Cap and any Window head can be used in combination.*

*Scale 3"=1'-0"*

## HOW TO SPECIFY VITROLITE

**STANDARDS** of good practice governing the installation of Vitrolite under specific conditions of use have been prepared and are available to architects or others on request. Reference can be made to Sweet's Catalog, to bulletins of the Producer's Council and to "Vitrolite in Architecture and Decoration" for detailed data. The following paragraphs summarize recommended procedure when Vitrolite is to be specified for storefront construction.

In extended form, the Vitrolite specification should cover the following:

**SCOPE OF WORK:** List in schedule form location, kinds and extent of structural glass, and details of thickness, color, special decorations, names, etc.

**MATERIALS:** Specify Vitrolite by name. Mastic should be specified as asphaltic mastic especially made for external use and approved by manufacturer and architect. Bond coating and joint cement should be similarly approved.

**COLOR AND FINISH:** Specify color as selected or to be selected. Specify whether surface is to be fire polished or mechanically polished and also the type

of finish for any decoration indicated on drawings. The back surface of the glass should always be specified as ribbed.

**SUBMISSION OF SAMPLES:** Samples may be requested of the various kinds of structural glass specified.

**SHOP DRAWINGS:** Complete shop drawings indicating jointing, thickness, color finish, etc., should be required.

**FABRICATION:** Specify cutting, fitting and setting according to approved details and shop drawings. Because Vitrolite is fabricated to exact sizes, special shapes of any character should be clearly specified. Specify treatment for all abutting edges, for angles at intersections of face and edges, exposed edges at salient angles, and concealed edges.

**CUTTING, DRILLING AND FITTING** should be specified to be done on the job by the contractor.

**INSTALLATION:** Preparation of surfaces for receiving Vitrolite should be carefully specified. When installation involves work of other trades such as masonry, ornamental metalwork, electric

wiring, etc., it is wise to make cross-reference to Vitrolite in such specifications. The contractor should be made fully responsible for the quality of the finished job by requiring his acceptance of the surface as prepared to receive Vitrolite before the commencement of his work.

Installation specification should cover: (a) condition of wall; (b) kind, thickness and distribution of mastic; (c) cushioning at sidewalk level; (d) thickness, cushioning and buttering of joints; (e) jointing against other materials; (f) material and distribution of shelf angles; (g) finish of top course; (h) provision against moisture penetration; (i) setting of ceiling and soffit slabs.

**PROTECTION, CLEANING AND POINTING:** Contractor should be required to protect work during construction to prevent penetration of moisture. Require also complete pointing and cleaning.

**GUARANTEE** covering installation against defects of material and setting workmanship and against breakage or separation from wall, except from violence or excessive heat, for a minimum period of eighteen months should be required.



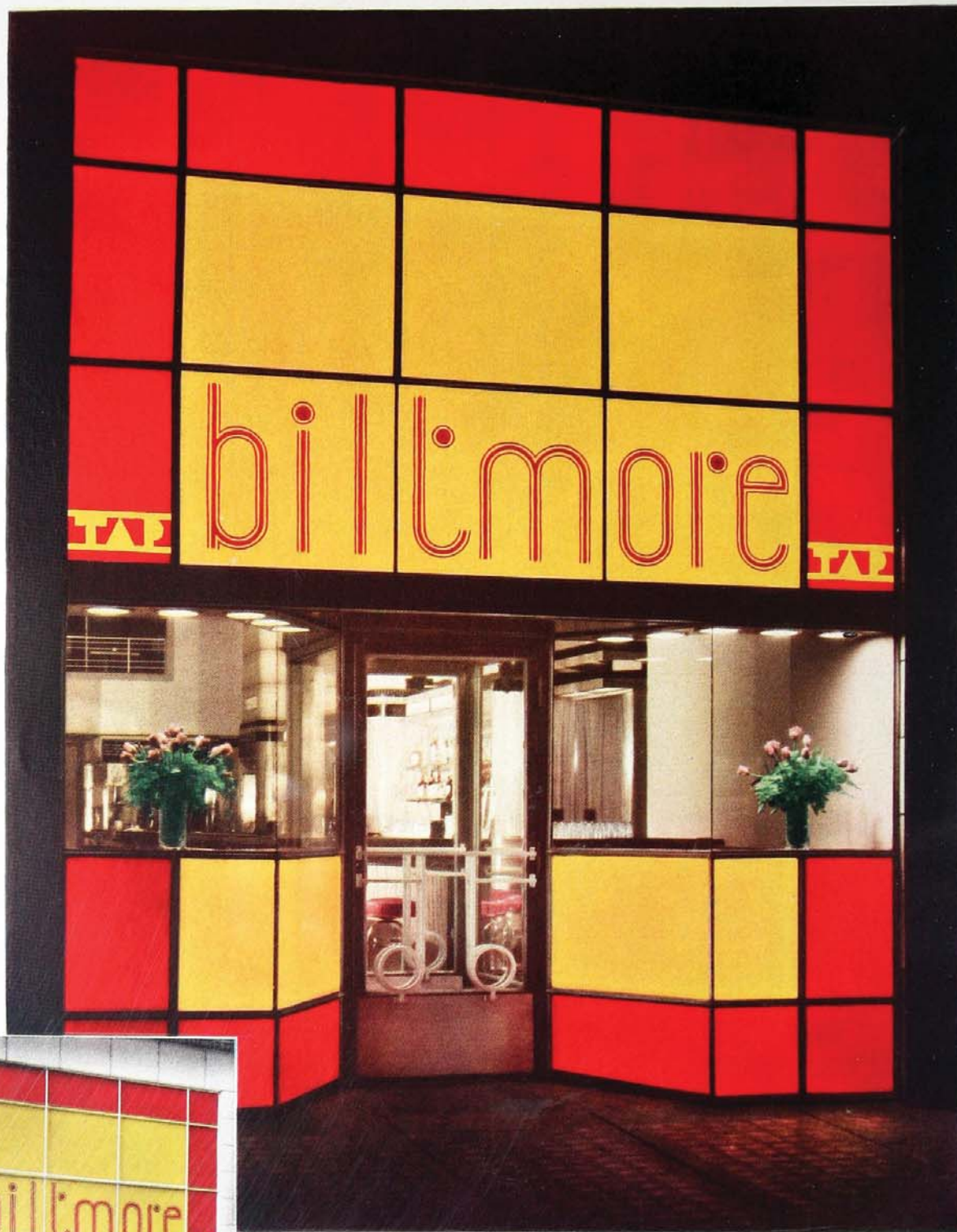

## LUMINOUS COLOR — NIGHT AND DAY

CONVINCING evidence of the day-and-night values of luminous color is shown in the design of this brilliant Chicago Cafe. Vitrolux has been used to face the storefront completely. During daylight hours it appears as a

smooth, colorful and opaque material contributing a clean, modern character to the design. At night it becomes radiant with luminous color and the entire surface gives off light that forcefully compels attention.



# VITROLUX COLOR-FUSED TUF-FLEX

A color-fused, tempered plate glass with unusually high strength and resistance to great thermal shock. Available in a wide range of translucent and opaque colors, it makes practical the development of modern storefronts that are strikingly colorful by day and completely luminous by night

**V**ITROLUX is tempered plate glass to the back of which a vitreous sun-fast type of color has been fused during the patented process of manufacture. It is a companion of Tuf-flex, the clear tempered plate glass, and has all the unique properties of that product. Vitrolux is exceptionally strong — it has from three to seven times the strength of regular plate glass — and is not damaged by impacts or radical temperature changes that would shatter other glass products. It can be bent or twisted far beyond the breaking point of regular plate glass. Vitrolux is not unbreakable. But if broken, it crumbles into relatively small particles resembling bath salts. These have a tendency to fly apart if the glass is not framed.

Two types of Vitrolux are available, opaque and translucent. These differ only with respect to light-transmission and diffusion and are developed according to the kind and amount of color fused to the glass during manufacture. They can be combined in a single sheet of Vitrolux in any two-color design. Translucent Vitrolux appears to be opaque when not illuminated. But it diffuses light with such exceptional uniformity that no bright spots reveal the source of illumination in any properly designed lighting installation. All colors of translucent Vitrolux do not diffuse light equally well. But the diffusion curve of translucent white is near theoretical perfection.

Vitrolux is made by a process in which plate glass sheets, cut to exact size and sprayed with vitreous color, are uniformly heated to a predetermined temperature that is just short of the softening point of glass. It is then suddenly and uniformly quenched to normal temperature by blasting the surfaces with cold air. This produces a highly, but uniformly, strained condition throughout the glass.

As a result of this tempering treatment, the physical properties of the glass are completely changed. Strains and stresses are created, which, because they are balanced, cannot be disturbed without damage to the glass. For this reason, Vitrolux must be manufactured to exact size, for thereafter the glass cannot be cut, ground, scored or otherwise worked.

The internal strength which the manufacturing process develops gives Vitrolux a toughness, strength and resilience similar in character to a steel spring. Vitrolux can be twisted through an angle of 20° without breaking and returns to its original plane with no permanent distortion. It withstands without damage impacts far beyond the point at which untempered plate glass would be shattered. Of still greater importance in storefront work is an extraordinarily small coefficient of expansion under heat and a resistance to thermal shock or temperature change several times greater than that of regular plate glass.



RESISTANCE TO THERMAL SHOCK is illustrated in this test. A sheet of Vitrolux resting on a cake of ice is undamaged by the heat of molten lead.



WHEN BROKEN, Vitrolux disintegrates into particles resembling bath salts. Greater impact is required to damage Vitrolux than regular plate glass.

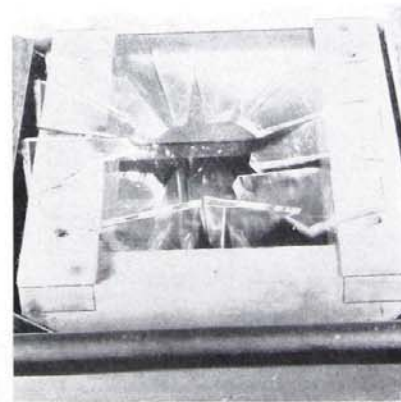

UNTEMPERED PLATE GLASS shatters when a 2-lb. steel ball drops only 8 inches on it. Vitrolux is undamaged until the ball drops 5 feet or more.



## I - COMPARISON STRENGTH OF VITROLUX AND PLATE GLASS

Kind of Glass	Glass Size 12" x 12"			Glass Size 18" x 18"			Glass Size 24" x 24"		
	Thickness (in.)	Breaking Pressure (Lb./Sq. In.)	Deflection (in.)	Thickness (in.)	Breaking Pressure (Lb./Sq. In.)	Deflection (in.)	Thickness (in.)	Breaking Pressure (Lb./Sq. In.)	Deflection (in.)
Plate 1	3/16	51.8	2.17	3/16	37	2.85	3/16	26.8	3.6
Plate 2	1/4	84.2	1.38	1/4	57	1.91	1/4	41.6	2.1
Plate 3	5/16	112	1.13	5/16	71	1.55	5/16	51.2	1.7
Plate 4	3/8	146	0.88	3/8	85	1.21	3/8	63.2	1.3
Plate 5	7/16	182	0.71	7/16	101	0.97	7/16	76.8	1.0
Average	3/8	112	1.13	3/8	85	1.21	3/8	63.2	1.3
Vitrolux 1	3/16	67	2.00	3/16	49	2.67	3/16	35.8	3.3
Vitrolux 2	1/4	81	1.81	1/4	57	2.07	1/4	42.2	2.5
Vitrolux 3	5/16	97	1.53	5/16	67	1.73	5/16	49.2	2.1
Vitrolux 4	3/8	115	1.30	3/8	79	1.47	3/8	57.2	1.8
Vitrolux 5	7/16	135	1.08	7/16	93	1.27	7/16	66.2	1.5
Average	3/8	115	1.30	3/8	79	1.47	3/8	57.2	1.8

## II - COMPARISON OF WEIGHT

Thickness	Standard Weight (Lb./Sq. Ft.)		Range (Lb./Sq. Ft.)	Range (Kg./Sq. M.)	Range (Lb./Sq. Ft.)	
	Thickness	Weight			Weight	Weight
3/16"	3/16"	4.01	3.92	57	3.97	3.96
1/4"	1/4"	5.34	5.25	77	5.30	5.29
5/16"	5/16"	6.67	6.58	97	6.53	6.52
3/8"	3/8"	8.00	7.91	117	7.86	7.85
7/16"	7/16"	9.33	9.24	137	9.20	9.19
1"	1"	12.00	11.91	177	11.86	11.85
1 1/8"	1 1/8"	13.33	13.24	197	13.20	13.19
1 1/2"	1 1/2"	15.00	14.91	217	14.86	14.85

Thickness given in the table weighs 1 sq. ft. Area of Vitrolux will be the weight of 1 sq. ft. Area of plate glass, with a saving of 1.00 lb. per sq. ft. or 10 percent of the glass weight, thus permitting a saving in weight of structural members.

## III - RESISTANCE TO THERMAL SHOCK

Kind of Glass	Average Difference in Expansion Coefficient (1/100,000)	Normal Difference in Expansion Coefficient (1/100,000)	Normal Difference in Expansion Coefficient (1/100,000)
1/4" Plate	100	100	100
1/4" Vitrolux	40	40	40

When used in Vitrolux window and doors in a line of glazing, when the window is exposed to variations of temperature caused by direct sun, the "tempered" glass window used for the maximum temperature difference for window 1/4" plate is 100° F. Vitrolux will not shatter until the surface temperature difference reaches 40° F.

## PROPERTIES OF VITROLUX

CHARACTERISTICS of Vitrolux are based upon actual tests conducted in accordance with the methods and procedures suggested by National Fire Protection Association. Vitrolux is a clear, tough, strong, and safe window material for use in areas where maximum resistance to impact and shattering is required. Its strength is approximately 50% greater than ordinary window glass and its heat resistance is about 100% greater than ordinary window glass. Because of these characteristics, Vitrolux can be used in areas where ordinary window glass is not recommended. Vitrolux is a composite plate of plate glass sheets affording a saving in weight ranging from 10 to 20 percent.

Results of these tests are contained in the accompanying tables. Table I compares the breaking load of Vitrolux and ordinary plate glass. The data show that individual samples of Vitrolux can withstand loads over 50% greater than breaking load on samples of ordinary plate glass and that the average breaking load on Vitrolux is 75% more greater than the average breaking load on plate glass. Deflection averages are approx. 50% less and a half more greater for Vitrolux windows of the same size as ordinary window glass.

Resistance to temperature change or thermal shock measured in degrees of temperature difference required to cause failure is shown in Table III. The maximum resistance of Vitrolux to temperature differential is evidenced by the data in the illustrations on page 40.

Temperature stability of expansion and contraction rates under various conditions of stress and strain and compressive strength are shown for Vitrolux and



ordinary plate glass in Table IV. Test data recorded in this table indicate that the modulus of rupture for Vitrolux averaged 4.8 times greater than that of untempered plate, and its defective averages 9.9 times greater.

Resistance to shock or impact is shown in Table V, and illustrated in photographs on page 45.

Table II gives actual and percent savings in dead weight resulting from the use of thinner sheets of Vitrolux in place of equivalent strength plate glass.

The color used on Vitrolux is finely powdered colored glass sprayed onto one surface of plate glass and then permanently fused during the tempering process. It thus becomes integral with the glass and is characterized by the same resistance to wear, weathering, craze or checking. Vitrolux can be made opaque or with varying degrees of translucency depending upon the amount of color applied. Normal solarization of plate glass which always occurs within a year or two after installation, does not materially alter Vitrolux colors.

IV - COMPARATIVE MODULUS OF RUPTURE							
ORDINARY PLATE GLASS				VITROLUX			
Thick. (Inch)	Deflection (Inch)	Breaking Load (Lbs.)	Modulus of Rupture (Lb./Sq.In.)	Thick. (Inch)	Deflection (Inch)	Breaking Load (Lbs.)	Modulus of Rupture (Lb./Sq.In.)
.238	.044	24.1	6,330	.264	.383	108.0	32,600
.228	.062	30.9	8,900	.266	.383	107.5	31,900
.228	.070	34.5	9,940	.263	.445	131.0	39,800
.228	—	37.5	10,600	.263	.503	137.0	41,600
.227	.041	22.4	6,520	.265	.450	134.0	40,400
.228	.047	23.7	6,500	.251	.402	99.0	32,600
.215	.035	18.5	6,140	.264	.380	105.0	31,600
.237	.044	24.5	6,570	.251	.505	129.0	42,500
.223	.047	21.3	6,640	.264	.382	105.0	32,000
		Average	7,570			Average	36,100

Vitrolux has high resistance to damage from impact. A 2-lb. steel ball must be dropped from a height of 5' or more to damage a sheet of 1/4" Vitrolux. It will shatter regular plate glass of similar size and thickness if dropped from a height of only 8 inches.

V - COMPARISON OF IMPACT		
Kind of Glass	2 Lb. Steel Ball	11 Lb. Shot Bag
	*Critical Distance in Inches	*Critical Distance in Inches
1/4" Plate	8	37
1/4" VITROLUX	60	168

\*By "critical distance" is meant the height through which an object must fall before impact to produce breakage or failure with approximately 50% of the samples tested.

## HOW AND WHERE TO USE VITROLUX

THE range of structural and decorative uses to which plate glass is adapted is greatly extended by special properties possessed by Vitrolux and Tuf-flex. Data on these two pages clearly show the remarkable superiority that characterizes Vitrolux in comparison with untempered plate glass. To utilize fully the wide possibilities of this material, it is necessary only to understand how the properties can affect the design of a structure in which it is used.

The unusually high strength of Vitrolux and its resistance to damage from impact and distortion makes it practical for use in locations where untempered plate glass could not safely or economically be installed. For example, Vitrolux will resist high wind pressures in exposed locations. It is practical for use in store bulkheads where sturdiness is necessary and for facade or spandrel facing in all cases which require luminous, colorful

and easily maintained surfaces combined with a saving of dead weight and a minimum of structural support.

Because it is less susceptible to breakage, Vitrolux can be used in panels larger than those ordinarily permitted for plate glass by building codes. This is particularly an advantage in sign work. An additional advantage of Vitrolux from the standpoint of public safety is the fact that upon fracture this glass disintegrates into comparatively small particles. These particles tend to fly in the plane of the glass and, therefore, it is desirable that Vitrolux be set so that the edges of each sheet will be protected.

Resistance to radical changes in temperature and the remarkable light-diffusing properties of translucent Vitrolux combine to make the development of large luminous areas practical. Built-in lighting with Vitrolux as a complete diffusing surface can be installed in any interior or exterior location. The glass

sustains no damage from thermal shock under any type of practical lighting condition. This permits a relatively shallow depth between the source of illumination and the glass surface without the danger of failure caused by a high temperature differential between the inner and outer surfaces of the glass. Its translucency permits the design of built-in lighting in such fashion that the entire surface of the glass becomes evenly luminous. For detailed lighting data governing the design of luminous Vitrolux forms refer to pages 52 and 53.

The daytime appearance of Vitrolux is such that this glass product may be used as a facing material in colors that harmonize with or match those of Vitrolite. By night the areas of Vitrolux give off luminous color. Opaque colors can be combined with those of translucent Vitrolux. Thus signs can become integral parts of a storefront; smoothly colorful by day, brilliantly luminous by night.



# CONSTRUCTION WITH VITROLUX

VITROLUX is manufactured in  $\frac{1}{4}$ " thickness only, to a maximum size of 4'-0" x 4'-0". No single light is furnished in proportions greater than 12 to 1, that is, minimum width for a 4'-0" panel is 4".

Vitrolux cannot be worked on the job like ordinary plate glass. Consequently, required shapes and sizes of Vitrolux must be manufactured from shop specifications so that any necessary holes may be drilled, patterns cut, and edges finished before it is tempered.

Minimum size for holes is  $\frac{1}{4}$ " diameter; and the minimum distance of holes or apertures from the perimeter of opening to the edge of glass is 1- $\frac{1}{2}$ ". Edges should preferably be seamed or swiped, ground, flat-polished, or  $\frac{1}{4}$ " radius polished bullnose. Miters or wide bevels materially weaken the glass.

Tong marks are normally found along one short edge, although small lights of

Vitrolux may be produced without them.

Opaque Vitrolux may be applied with mastic like ordinary structural glass. Translucent Vitrolux may be installed as ordinary glass with putty or standard glazing beads in any standard type of framed opening. Both varieties may also be held by the Extrudalite sections designed particularly for this purpose (refer to pages 19 to 35, inclusive). In all cases the edges of Vitrolux should be protected from damage during installation.

Illustrated on these two pages and on page 50 are a number of typical applications of Vitrolux. Drawings are primarily suggestions for installing the material in a very wide range of structural conditions.

Major uses of Vitrolux in storefront construction include:

*Luminous facings* formed by framing Vitrolux with Extrudalite or other metal members over a lighting installa-

tion (refer to pages 52 and 53 for data).

*Signs*, as projecting elements or as transom areas with or without division bars. Opaque and translucent Vitrolux can be combined to produce integral lettering, or opaque letters can be applied to silhouette against a luminous background.

In this and other exterior work, a specially designed  $\frac{1}{4}$ " Extrudalite metal bead can be used at vertical joints in place of heavy division bars. The design of this bead renders it almost invisible when the sign is illuminated. It also affords an excellent method of waterproofing the vertical joints. An allowance of  $\frac{1}{8}$ " in the dimensions of Vitrolux at each vertical joint should be made when this bead is used.

*Luminous ceilings* for both interiors or exteriors may be of Vitrolux supported on edges of wall materials, on small T-bars or by Extrudalite sections.

*Luminous marquees* may have a fully luminous ceiling with luminous facias which form a background for removable silhouette letters (see page 14).

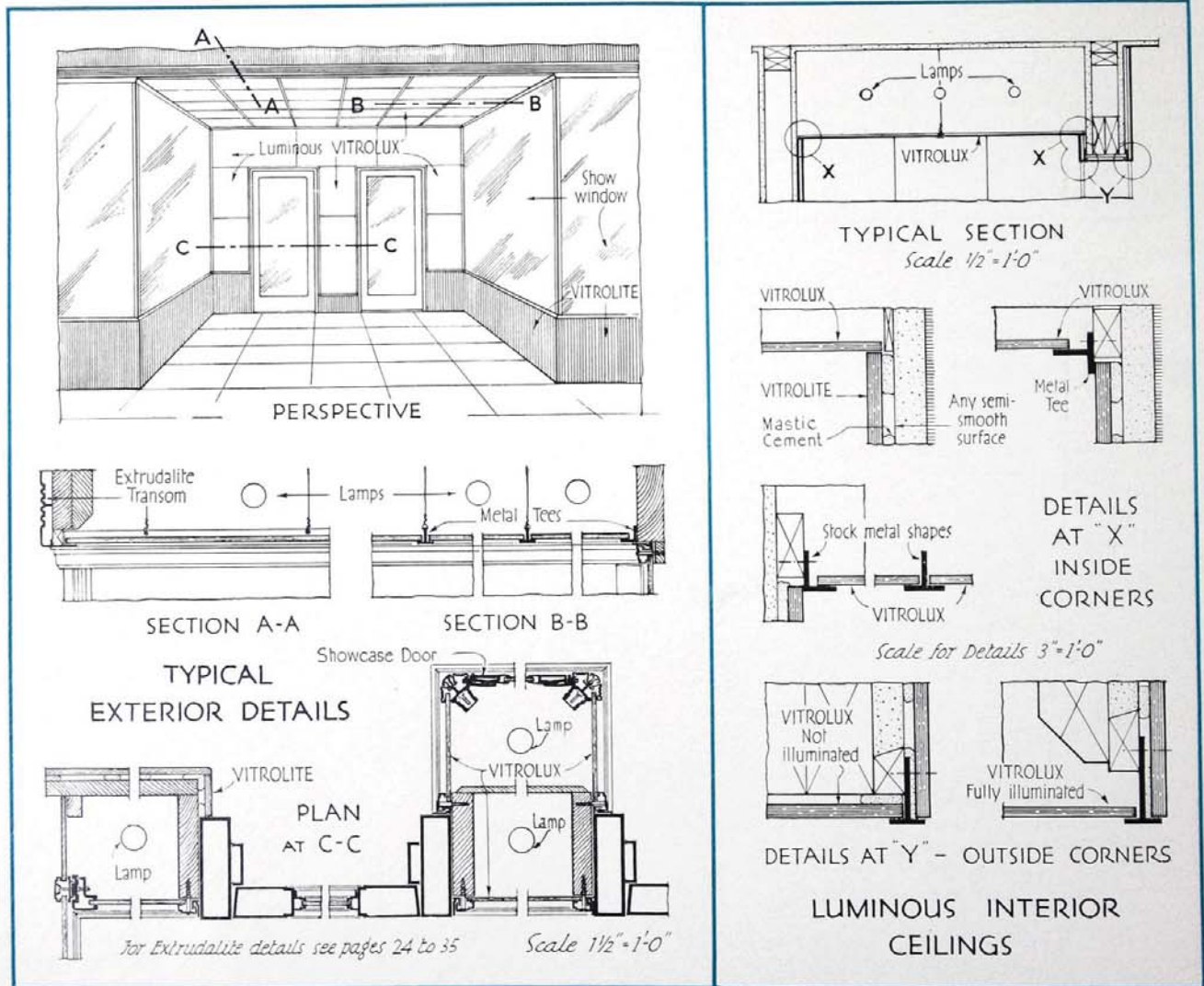



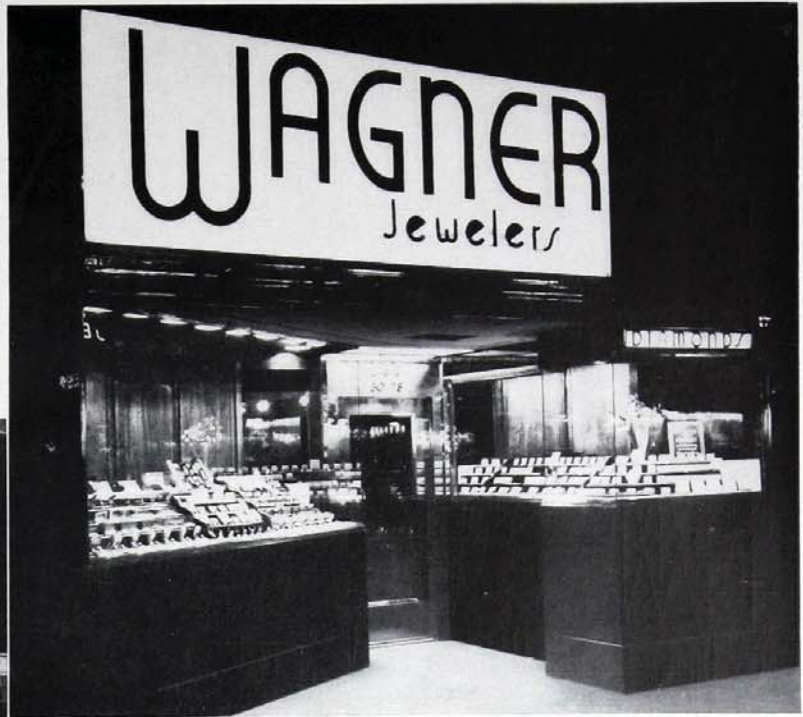
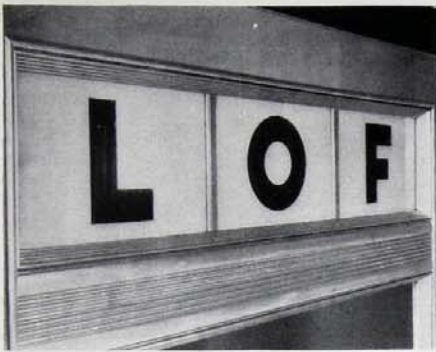

Vitrolux sign panels of two widely adaptable types. At upper left, opaque letters were fused integrally with a contrasting translucent field. In the sign above, Vitrolux is installed as a background without vertical bars.

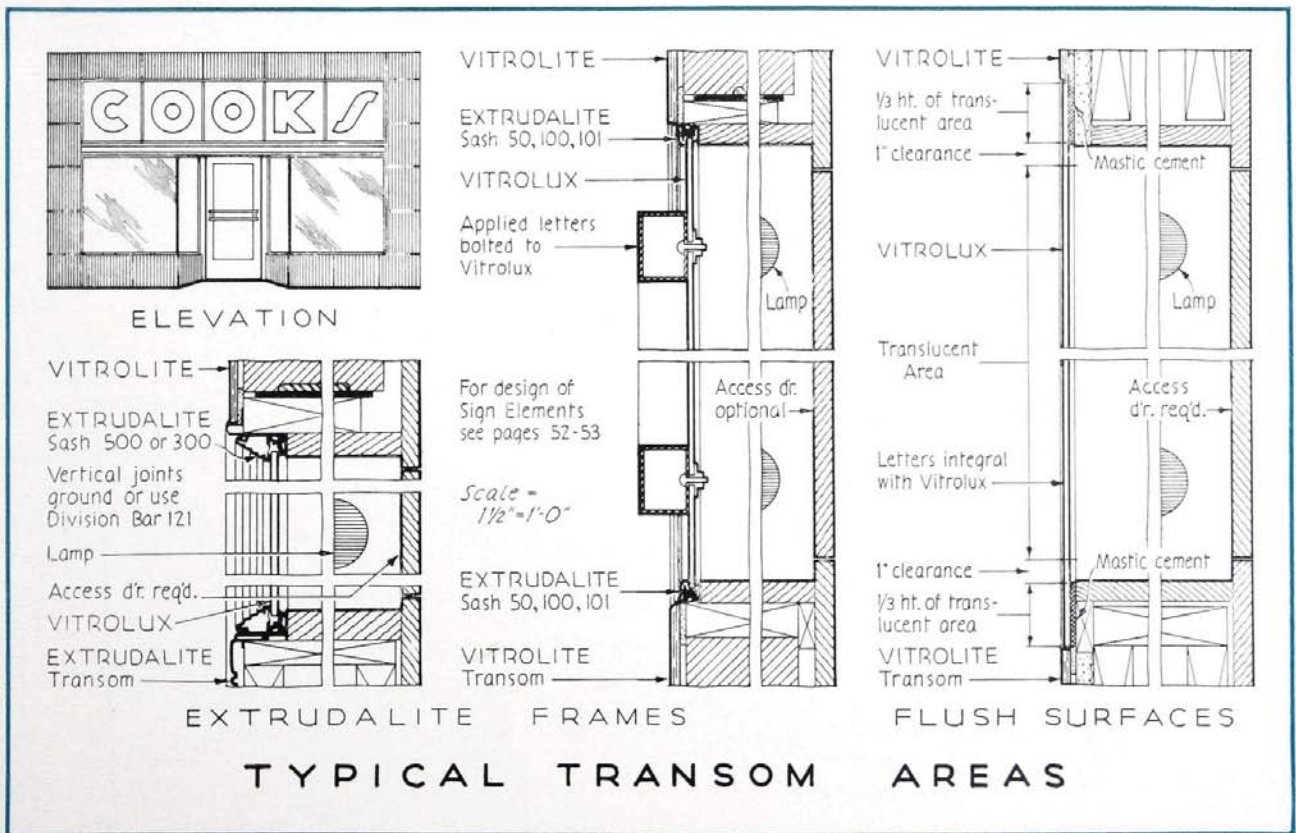



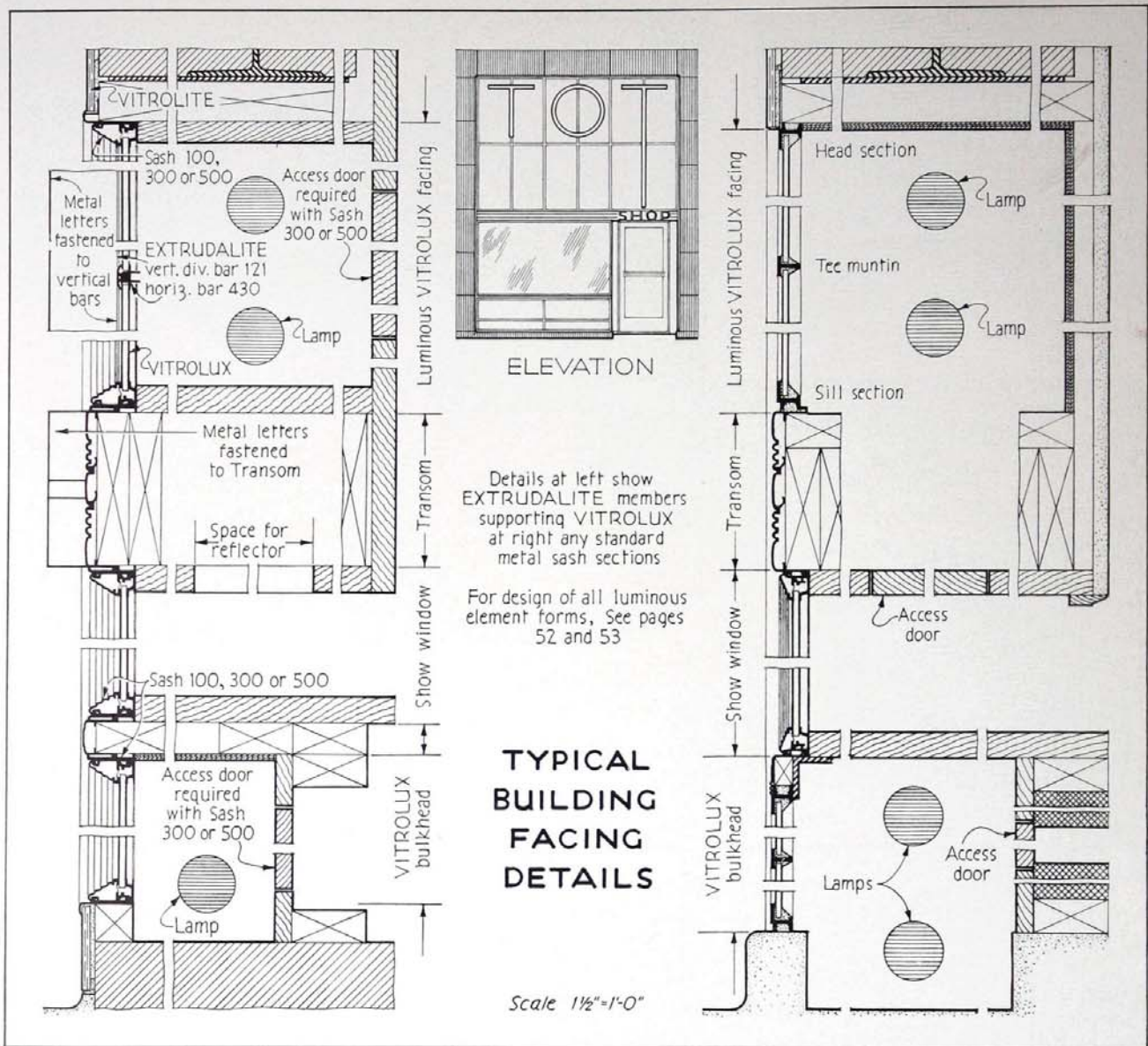

## VITROLUX COLORS ARE MANY AND VARIED

Colors of Vitrolux are translucent or opaque depending on the amount of coloring materials employed in their manufacture.

**TRANSLUCENT COLORS** include:

White	Light Orange	Brilliant Red
Bright Yellow	Deep Orange	Apple Green
Yellow	Chinese Red	Sun Tan

Night and day appearance of these colors is not the same. Light passing through translucent Vitrolux to produce a luminous surface invariably changes the intensity and shade of all unilluminated colors.

Therefore, to visualize the vivid effects of translucent Vitrolux, both unilluminated and illuminated, it is advisable to inspect actual samples of the material. Translucent colors are solid, except Apple Green and Sun Tan which may show a slight mottling of pleasing character when illuminated.

**OPAQUE COLORS** are made in somewhat wider range. There are ten opaque Vitrolux colors, three of which match the solid Vitrolite colors shown on page 39. In addition, special opaque colors can be developed, provided they are no lighter than standard gray.





A modern and well-designed storefront by day becomes even more attractive at night through the use of light and color. Due to construction with Vitrolux, luminous color is introduced as a new element in architectural design.



## LUMINOUS COLOR A NEW ELEMENT IN DESIGN

AS a powerful means of attracting attention to any sort of display both color and light have won important positions as elements of modern design. But until recently technical problems of combining the two successfully have forced designers to employ them sparingly and have made it impossible to use luminous color widely.

Vitrolux, however, renders luminous color practical as a new and stimulating element of architectural design. The material combines wide ranges of color, various degrees of translucency and an almost perfect quality of light diffusion. In addition, the strength of Vitrolux and its high resistance to great and sudden changes in temperature make it ideally suited to the production of luminous color areas in an almost endless variety of shapes and sizes, because it is unaffected by the considerable heat

generated by incandescent lamps used to light such areas.

By day the color of Vitrolux appears opaque. The material is so similar in all outside characteristics to Vitrolite that the two products can be used side by side to produce virtually limitless combinations of color and pattern with smooth gleaming surfaces. By night the areas of Vitrolux present surfaces of rich light that glow in an even spread of radiant color in sharp relief against the darkness of opaque materials which adjoin them.

To the progressive merchant and imaginative architect the vast potentialities of luminous color need only be suggested. The availability of Vitrolux creates possibilities for using light and color as an integral part of building design in ways that have never before been practical.

Vitrolux storefronts may be designed to any degree of luminosity suited to the surroundings. They can be made a brilliant and colorful beacon to attract consumers against the competitive bidding of neighboring shops.

Further, luminous color as a new architectural medium gives the architect a wider latitude in arranging the elements of storefront design. Physical forms may be simplified; structural problems made less complicated and architectural design made striking with smooth, easily maintained surfaces that give off colorful light.

The qualities of Vitrolux make it practical to capitalize the values of modern materials and advanced methods of construction. Luminous color can now be employed to the fullest extent as a new element for the design of any type of storefront.



# LIGHTING DATA FOR LUMINOUS VITROLUX FORMS

**T**O USE Vitrolux most effectively in storefronts or where luminous color becomes an important element of design, the simple rules on these two pages should be observed.

In general, lighting efficiency is governed by the size and desired brightness of the luminous unit, the relative location of lamps, their wattage and spacing, and the character of the light-diffusing surface. Data on these two pages reflect good lighting practice as applied to various uses of translucent Vitrolux in white and a variety of colors. For data on sign lighting, see page 16.

## LIGHTING METHOD

The recommended lighting of translucent Vitrolux Glass is accomplished by placing electric lamps behind the glass and enclosing them with reflecting surfaces which may assume various shapes or forms referred to as Element Forms. While no general set of design data can embrace all the conditions encountered in luminous architecture, the eight Element Forms illustrated in Table II are typical.

## REFLECTING SURFACE

Economy and effective luminosity require complete enclosure of the lamps behind the glass with a reflecting surface of high efficiency. All interior surfaces should have a white finish such as mat white paint.

**TABLE I — BRIGHTNESS VALUES FOR LUMINOUS INSTALLATIONS**

(Recommended averages in Foot-Lamberts)

Type of Luminous Installation	General Brightness of District		
	Low	Medium	High
Luminous store fronts, luminous transoms, luminous backgrounds and signs.....	80-130	100-200	150-350
Projecting units of dominant character.....	50-130	70-170	150-300
Decorative flush units (Principal units in design)...	30-100	50-150	100-300
Translucent letters with an opaque background.....	150-200	200-400	300-600
Marquees, pylons, gasoline service stations, etc.....	80-150	100-250	200-400
Interior ceiling installations: (Approx. upper limits)			
High ceilings.....	500		
Low ceilings.....	250		
Interior bathroom and shower ceilings.....	75		

## ELECTRICAL EQUIPMENT

The lighting design is based upon the use of standard Mazda lamps, and no special fittings or reflectors are required in most elements.

## BRIGHTNESS

The desirable brightness for luminous displays governs the lamp wattage to be selected. Brightness is the degree of brilliancy of a surface and is measured in Foot-Lamberts. A luminous surface of too high brightness causes glare while a luminous surface too low in brightness is drab and unattractive. An installation of any given Foot-Lamberts will have an effect of low brightness or high brightness under varying conditions such as size and brightness of nearby displays and surrounding areas and size of the installation itself. And different types of commercial establishments require not only a careful color selection but different degrees of brightness to provide the desired effect. With certain colors, too, a lower brightness often proves effective.

## USE OF TABLES

Table I lists various types of installation and recommends the degree of brightness most advantageous in low-, medium- or high-brightness districts. In selecting the lamp wattages from Table II only an approximate brightness value is required from Table I.

## ELEMENTS

Most of the eight luminous element forms illustrated in Table II are adaptable to typical Vitrolux applications such as — No. 3, shallow backgrounds; No. 1, use of lower wattage; No. 5, more suitable to corner installations.

## LAMP LOCATION AND SIZE

After selection of the element form, the table accompanying the element chosen will determine such factors as size and wattages of lamps, distance from the back of the glass to the center of the lamp and correct spacing between lamps. In the tables below, *W* represents the width of the Vitrolux glass to be illuminated; *D* is the distance from the back of the Vitrolux glass to the center of each lamp; and *S* is the maximum spacing between lamps for uniformity of brightness (measured between centers of filaments).

Data given in each table are based on the use of white Vitrolux. For use of colored Vitrolux, see page 53.

*Example:* For a transom sign 30" high the element form must first be chosen. If No. 2 is chosen, 30 in the column headed *W* shows that lamps should be 10 inches behind the glass and 15 inches apart. The other figures at the right represent varying degrees of brightness as set forth in Table I. If brightness 150 is selected, use 60-watt lamps.

**TABLE II—AVERAGE BRIGHTNESS VALUES FOR LUMINOUS ELEMENTS OF WHITE VITROLUX**

(Computed in Foot-Lamberts with allowances made for depreciation from initial values)

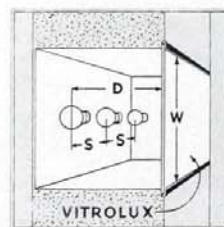

$$D = 2/3 W \quad S = W$$

$$D = 1/3 W \quad S = 1/2 W$$

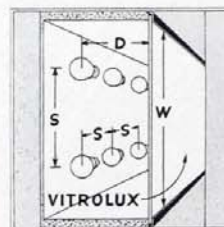

Dimensions in Inches	ELEMENT FORM No. 1													
	Watts per Lamp													
W D S	10	15	25	40	50	60	75	100	150	200	300	500	750	1000
6 4 6	90	160	290	500										
9 6 9	40	70	130	220	295	415	535							
12 8 12	20	40	70	125	165	230	300	430						
15 10 15		25	45	80	105	150	195	275	465					
18 12 18			30	55	75	105	135	190	320	455				
24 16 24				30	40	60	75	105	180	255	410			
30 20 30					25	35	50	70	115	165	260	450		
36 24 36						25	35	50	80	115	180	310	455	
48 32 48								25	45	65	105	175	255	360

Dimensions in Inches	ELEMENT FORM No. 2													
	Watts per Lamp													
W D S	10	15	25	40	50	60	75	100	150	200	300	500	750	1000
12 4 6	90	160	290	500										
18 6 9	40	70	130	220	295	415	535							
24 8 12	20	40	70	125	165	230	300	430						
30 10 15		25	45	80	105	150	195	275	465					
36 12 18			30	55	75	105	135	190	320	455				
48 16 24				30	40	60	75	105	180	255	410			



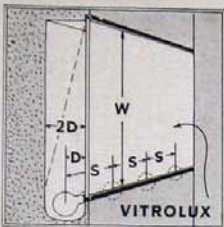

$D = 1/10W$   $S = 2/10W$

		ELEMENT FORM No. 3													
Dimensions in Inches		Watts per Lamp													
W	D S	10	15	25	40	50	60	75	100	150	200	300	500	750	1000
16	2 4	25	45	85	145	190	265	345	490						
24	2 1/2 5	25	50	85	115	160	210	295	500						
30	3 6	35	55	75	105	140	195	330	470						
36	3 1/2 7	40	55	75	100	140	240	335	535						
48	5 10					30	40	50	75	125	175	280	480		

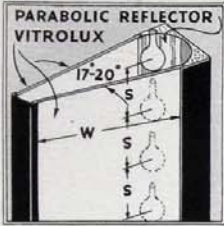

$S = 2/5W$

		ELEMENT FORM No. 4													
Dimensions in Inches		Watts per Lamp													
W	D S	10	15	25	40	50	60	75	100	150	200	300	500	750	1000
18	8			35	65	85	115	155	220	370	520				
24	10			40	50	70	100	130	220	315	500				
30	13					30	45	55	80	135	195	310	530		
36	15						30	40	60	100	135	215	380	555	
42	18							30	40	70	100	165	270	400	
48	21								30	55	75	120	205	300	425

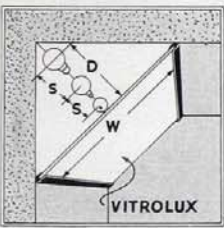

$D = 2/5W$   $S = 3/5W$

		ELEMENT FORM No. 5													
Dimensions in Inches		Watts per Lamp													
W	D S	10	15	25	40	50	60	75	100	150	200	300	500	750	1000
12	5 7 1/2	40	65	125	215	285	400	515							
15	6 9	25	45	85	140	190	265	345	490						
18	7 10 1/2	30	60	100	135	190	245	350	590						
24	10 15			30	55	70	100	130	185	310	440				
30	12 18				35	45	65	85	120	210	290	465			
36	14 21					35	45	60	85	150	210	335	575		
48	19 29						25	35	50	80	110	180	320	450	

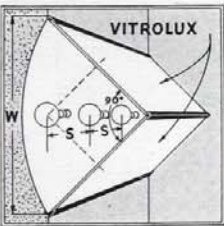

$S = 1/2W$

		ELEMENT FORM No. 6													
Dimensions in Inches		Watts per Lamp													
W	D S	10	15	25	40	50	60	75	100	150	200	300	500	750	1000
12	* 6	40	70	130	220	295	415	535							
18	* 9	30	55	100	130	185	240	340	570						
24	* 12		30	55	75	105	135	190	320	445					
30	* 15			35	45	65	85	120	205	290	465				
36	* 18				35	45	60	85	145	200	320	555			
48	* 24					25	35	50	80	115	180	310	450		

\* Position Lamps Equidistant from the two sides.

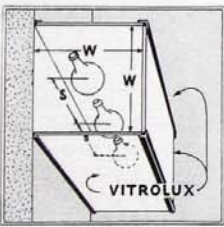

$S = 3/4W$

		ELEMENT FORM No. 7													
Dimensions in Inches		Watts per Lamp													
W	D S	10	15	25	40	50	60	75	100	150	200	300	500	750	1000
12	6 9	25	50	85	115	160	205	290	495						
18	9 13 1/2	20	40	50	70	90	130	220	315	500					
24	12 18			30	40	50	75	125	175	280	480				
30	15 22 1/2				25	35	45	80	110	175	310	450			
36	18 27					25	35	55	80	125	215	310	445		
48	24 36						20	30	45	70	120	175	250		

$S = 7/10W$

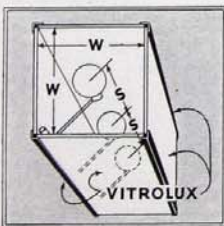

		ELEMENT FORM No. 8													
Dimensions in Inches		Watts per Lamp													
W	D S	10	15	25	40	50	60	75	100	150	200	300	500	750	1000
12	6 8 1/2			45	80	105	145	190	270	460					
18	9 12 1/2			35	50	65	85	125	210	295	470				
24	12 17				25	35	50	70	115	160	260	445			
30	15 21					25	30	45	75	105	165	290	420	595	
36	18 25							30	50	75	115	200	290	410	
48	24 34								30	40	65	110	160	230	

## VITROLUX IN COLORS OTHER THAN WHITE

THE same procedure is followed in the design for lighting for colored Vitrolux, using the same values of "D" and "S" as are used for White Vitrolux.

Lamp wattages as determined in Table II for white Vitrolux may also be used for: Ivory, Yellow, Bright Yellow, Light Orange, Deep Orange, Chinese Red, Brilliant Red and Bright Red.

The next larger size of lamp is recommended for: Pastel Green, Sea Green, Apple Green, Light Blue and Baby Blue.

Lamps two sizes larger than those determined by Table II are recommended for: Irish Green, Dark Green, Dull Green and Medium Blue.

For example, in working out an installation in which Table II requires 60-watt lamps for white Vitrolux, use 75-watt lamps if Pastel Green Vitrolux is used. If Irish Green Vitrolux is to be installed, use 100-watt lamps instead of 60-watt lamps.

Incident light transmission factors for the eighteen standard colors of translucent Vitrolux may vary from a high of 35.6% for white to a low of 4.1% for Irish Green, the lower values being caused by the absorption of light to produce color.

NOTE: The accompanying tables giving data on various Element Forms are based on enclosed white reflecting surfaces reflecting 75% of the light.

For the sake of simplicity, only a single sheet of Vitrolux glass covers the face of the element in each of the element forms illustrated. But it is, of course, possible to use any desired number of pieces of glass for the face of the element.

To produce luminous areas larger than those shown in the tables, element forms may be combined one above or beside the other. For example, the design of lighting for an area 12 ft. high may be composed of 3 units of Element Form No. 1, each 48" high, and the size and location of lamps determined directly from the table of Element Form No. 1. In this case the abutting reflecting surfaces of the three combined elements may be omitted, enclosing the lamps with the outer end and rear reflecting surfaces only.

If such a design results in a depth greater than practical, the distance behind the glass may be reduced by designing the lighting to be comprised of four element forms each 36" high, etc.

In figuring wire sizes and circuit layout, it is good practice to allow capacity for at least one size larger lamp than planned to provide a margin for testing or future increases in brightness.





A simple but effective sign in which contrasting colors of Vitrolux are combined. Lettering is opaque against a translucent field, forming a colorful and attractive panel by day and a smooth, glowing area of luminous color at night.



## HOW TO SPECIFY VITROLUX

**S**PECIFICATIONS for Vitrolux should be substantially as follows:

*"Where tempered plate glass with either translucent or opaque color is specified or shown on plans, it shall be Vitrolux manufactured by the Libbey-Owens-Ford Glass Company in sizes and shapes as shown on full size or scale detail drawings. It shall be installed in strict accordance with the manufacturer's instructions to match colors of approved samples as indicated."*

When use of Vitrolux involves work of other trades as masonry, electrical wiring, ornamental metalwork, etc., cross reference should be made in the specifications. These should cover: (1) *Scope of Work*; List all areas where Vitrolux is to be used; (2) *Method of Application*; Describe type of glazing, pointing, etc.; and (3) *Structural Conditions*; Describe preparation of all interior or exterior areas to receive Vitrolux.

Since Vitrolux cannot be cut, ground, polished, edged or otherwise worked on the job, it must be ordered to exact size and specification. It is, therefore, important that the architect make complete working drawings and full size details of every special piece of Vitrolux. Location, size and finish of joints should be indicated. For limiting factors in design, as holes, maximum sizes and thicknesses, edgework, etc., refer to "Construction with Vitrolux" on page 48.

**ORDERS** for Vitrolux in standard colors can normally be filled in approximately two weeks after receipt at factory. Orders for Vitrolux specifying special opaque colors cannot normally be filled in less than three weeks. To facilitate execution of orders, all scale or full size detail drawings and specifications should be as completely detailed and as definite as possible. Otherwise additional time will be required at the factory for

full size detailing in addition to shop drawings.

The following information is required in ordering each piece of Vitrolux: Color, quantity, description, piece number, size, finish and sketch. If a design involves any special requirement, advice of an L.O.F. technician should be obtained before detailing. Drawings and specifications should cover completely these points:

**COLOR** should be designated by stock name and number or to match approved samples. Where two colors are used on a single piece of Vitrolux, full size or large scale details should indicate distribution of color and exact pattern desired.

**FINISH** should indicate whether edges are to be seamed (furnished at no extra charge), ground, flat-polished or  $\frac{1}{4}$ " radius bullnose polished.



# BLUE RIDGE DECORATIVE GLASSES

**B**LUE RIDGE GLASS CORPORATION products, distributed by the Libbey-Owens-Ford Glass Company, include Rolled Figured and Wire Glass. Made in a wide range of patterns which transmit and diffuse light in varying degrees as required, Blue Ridge Glasses find traditionally widespread application in partitions, doors, transoms, skylights, windows and general industrial use. In addition, the contemporary trend toward a fuller use of glass for both decorative and utilitarian purposes is constantly evolving new applications in the form of decorative screens and panels, lighting fixtures, double glass walls, museum and exhibition lighting, etc.

In the development of modern storefronts which combine design elements of light and color with advanced methods of construction, Blue Ridge Glasses are particularly suitable in a variety of applications. All possess in varying degrees the characteristic of light diffusion and the ability to transmit light but obscure vision. These qualities, together with the surface textures of the various patterns, suggest the use of Blue Ridge Glasses for bulkheads, for portions of store windows which can properly be obscured in order to focus attention on a small display and for background and ceiling panels, in larger display areas.

Methods of using Blue Ridge Glass for such purposes depend largely on the whim of the designer. For example, it can be set in Extrudalite frames as a single membrane or, as illustrated below, in a partition with double membrane between which can be installed a variety of lighting installations. It can be secured in lead comes or held by simple wood or metal moldings for interior installations.

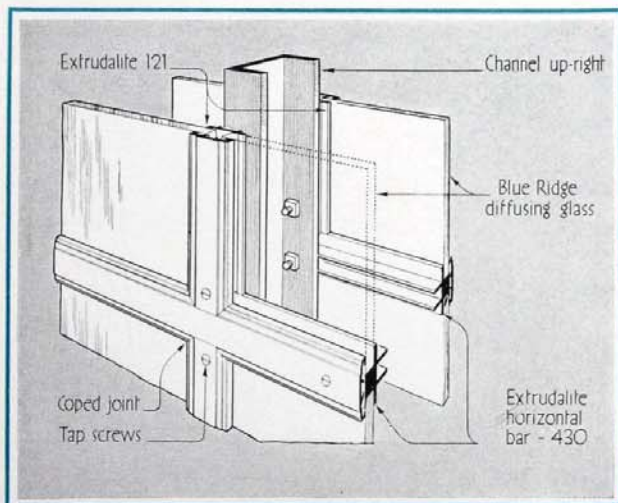

A hollow wall easily formed of Extrudalite and any type of Blue Ridge Glass suggests a wide range of practical uses for these modern materials on all sorts of interiors and exteriors.

The following practices should be observed in installation:

(1) In openings exposed to fire hazard, size of wire glass is limited by requirements of the National Board of Fire Underwriters. In brief, the unsupported area of the glass must not measure more than 48" in either dimension, or exceed 720 square inches; also wire glass must be set in non-inflammable materials.

(2) Wire glass is usually set with the wire running vertically, hence the width (always given first in ordering glass) is understood to be across the wire twists.

(3) Ribbed and Skytex Glasses are usually set with the ribs running vertically; hence the width is considered to be across the ribs unless shown otherwise.

(4) Prism glass distributes light best when prisms are set horizontally or parallel to width.

A short form specification, approximately as follows, will serve: "*where figured or polished wire or obscure glass is specified herein, or shown on plans, it shall be . . . inch in thickness and shall be . . . . . pattern, as manufactured by the Blue Ridge Glass Corporation.*" If Satinol processed glass is required, add "*. . . pattern Satinol*" (one surface or two surfaces). A label on every light of Satinol-Processed Blue Ridge Glass states the extent of processing.

Thirteen patterns in Blue Ridge Rolled Figured Glass are illustrated on pages 56 and 57, and their properties described. Ten of these are furnished plain or wired. Mazex and Prism are additional Blue Ridge patterns which are not illustrated. Blue Ridge Glass is carried in stock by leading glass jobbers and glazing contractors. Quick shipment of any size, pattern and thickness can be made from the factory.

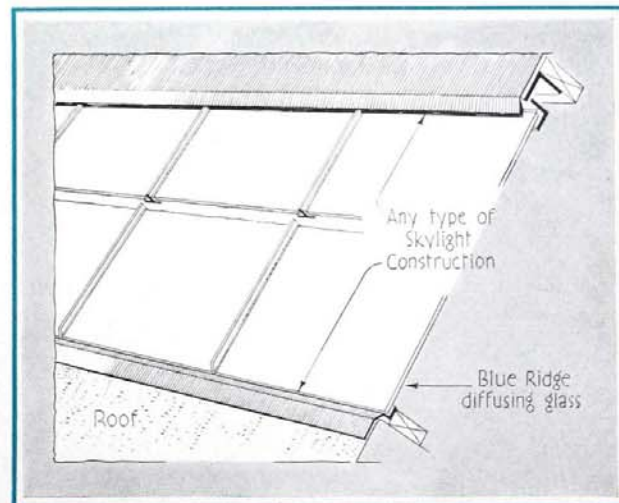

Advantages of Blue Ridge Glass are traditional in skylights, transoms, windows and partitions which require obscure glass with or without the fire protection of properly spaced wire.



# CHARACTERISTICS OF BLUE RIDGE DECORATIVE GLASSES

**B**LUE RIDGE glasses vary considerably in obscurity, transmission and diffusion, depending on surface pattern. They are generally characterized by (1) uniform quality and thickness; (2) brilliant surface, easily kept clean; (3) variety of surface pattern designed for effective transmission and diffusion of light; and (4) versatility of use. Blue Ridge wire glass is fire-retardant and approved by Underwriters' Laboratories, Inc. (Number R-2129) for such use.

**FIRE-RETARDING ABILITY** and resistance to impact and wind pressure of wired glass depends largely on the exact centering of wire in the glass. Tests have shown that glass in which wire is properly centered is 42 percent stronger than that in which the wire is substantially closer to one surface than the other. Blue Ridge Glass is manufactured by an exclusive process which insures effective centering of the wire and further insures freedom from clusters of bubbles on the wire, an important appearance consideration. The wire itself is clean and untarnished.

**TRANSMISSION OF LIGHT** is shown in percentage figures for each type of glass in the accompanying tables; these should be accepted as approximate only in specifying glass for factory and commercial buildings. Positive values for this factor cannot be established for two reasons: first, laboratory apparatus for determining transmission values shows

wide variation even in the hands of experienced observers; second, laboratory tests are always made on thoroughly clean samples of glass.

Glass in buildings cannot be kept in the same spotless condition and thereby loses a considerable ability to transmit light. Clear glass set vertically may lose as much as 50 percent of its original efficiency due to dirt collection within six months after installation. Similarly, glass at an angle of 60° may lose as much as 83 percent of its initial efficiency.

To maintain light transmission efficiency patterns of Blue Ridge glasses were designed to permit full and easy cleaning. Wired glass normally has about 10 percent lower efficiency in transmitting light than unwired glass of the same pattern, thickness and batch composition.

**DIFFUSION OF LIGHT** or the distribution of light as it passes through glass so that bright spots and glare are minimized, is not equally effective in all Blue Ridge figured glasses. Complete diffusion or the *elimination* of glare caused by contrasting bright spots on the surface of the glass cannot be accomplished with any type of figured glass made today; and no manufacturer can guarantee, in good faith, that his product will do that. In general, glasses which produce high degrees of diffusion do not transmit as much light as those with a lower diffusing capacity.

Blue Ridge glasses particularly designed for high diffusing efficiency are

Pebblex, Muralex, Diffusex and Industrex. Patterns transmitting a greater volume of light without great distribution include Hammered, Luminex or Velvex. Ribbed and Prism patterns throw light mainly in two directions.

**SANDBLASTING** of figured glass tends to improve its light diffusing quality. But it decreases light transmission by 16 percent when applied to one surface and from 20 to 30 percent on both surfaces depending upon the glass pattern. Also it collects dirt quickly and makes cleaning more difficult.

**SANITOL** is a special process for finishing Blue Ridge glasses in lieu of sandblasting. It materially improves the light diffusing quality of any glass and imparts a mellow, satin-like finish which does not show spots or finger marks. Sanitol reduces light transmission by about 3 percent on one surface and 6 percent on both surfaces.

**NOTE:** Where accompanying tables show 48" as maximum width, some patterns may be available in 60" widths depending upon stock on hand. Also, greater thicknesses may be obtained on special order. Louvrex, Reglex, Diffusex, Muralex and Pebblex are available polished. Louvrex, Muralex, Velvex and Luminex are carried in stock with one or both surfaces Satinol-Processed. Illustrations on these two pages show actual size of patterns except where noted.

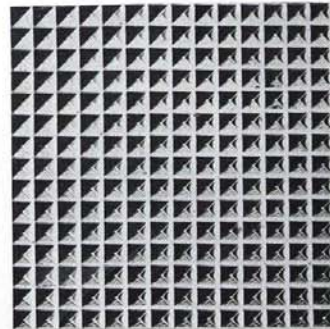
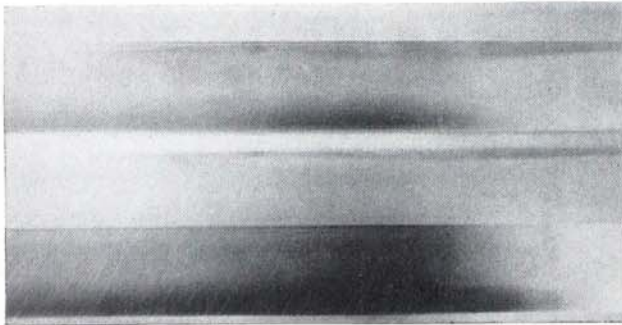

REGLEX

	Plain	Wired
Thickness, ins.	1/8, 3/16, 1/4	
Max. width, ins.	48	
Max. length, ins.	132, 136	not made
Approx. wt., lbs. per sq. ft.	2, 2 3/4, 3 1/2	
Approx. light trans., %	52.3	

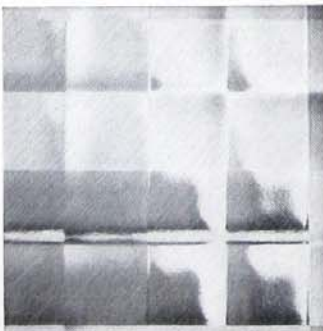

LOUVREX

Illustrations 1/2 full size

	Plain	Wired
Thickness, ins.	approx. 1/4	
Max. width, ins.	54	
Max. length, ins.	136	not made
Approx. wt., lbs. per sq. ft.	3 1/2	
Approx. light trans., %	90.0	

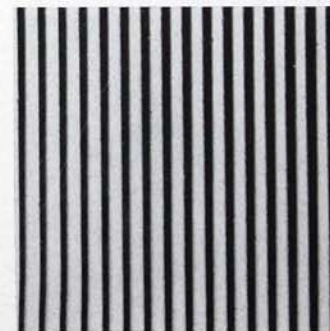

SKYTEX

	Plain	Wired
Thickness, ins.	1/8, 3/16, 1/4	1/4
Max. width, ins.	48	48
Max. length, ins.	132, 136	144
Approx. wt., lbs. per sq. ft.	2, 2 3/4, 3 1/2	3 3/4
Approx. light trans., %	66.8	56.8



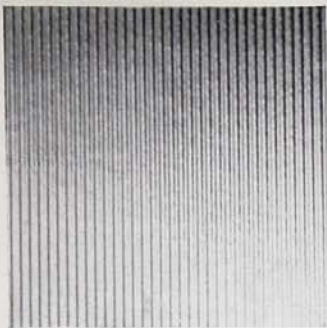

### RIBBED

	Plain	Wired
Thickness, ins.	$\frac{1}{8}, \frac{3}{16}, \frac{1}{4}$ $\frac{3}{8}, \frac{1}{2}$	$\frac{1}{4}, \frac{3}{8}, \frac{1}{2}$
Max. width, ins.	48	48
Max. length, ins.	90, 132, 136	90, 144
Approx. wt., lbs. per sq. ft.	$2, 2\frac{3}{4}, 3\frac{1}{2}$ $5, 6\frac{3}{4}$	$3\frac{3}{4}, 5, 8$
Approx. light trans., %	84.4	74.4

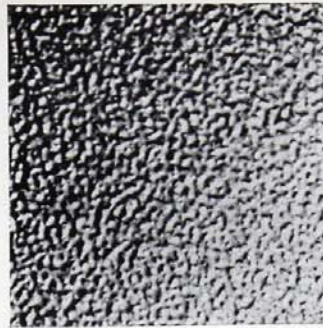

### MURALEX

	Plain	Wired
Thickness, ins.	approx. $\frac{1}{4}$	$\frac{1}{4}$
Max. width, ins.	48	48
Max. length, ins.	136	144
Approx. wt., lbs. per sq. ft.	$3\frac{1}{2}$	$3\frac{3}{4}$
Approx. light trans., %	86.0	76.0

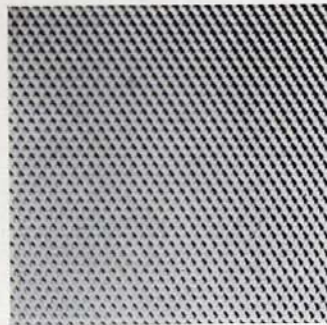

### INDUSTREX

	Plain	Wired
Thickness, ins.	$\frac{1}{8}, \frac{3}{16}, \frac{1}{4}$	$\frac{1}{4}$
Max. width, ins.	48	48
Max. length, ins.	132, 136	144
Approx. wt., lbs. per sq. ft.	$2, 2\frac{3}{4}, 3\frac{1}{2}$	$3\frac{3}{4}$
Approx. light trans., %	88.2	78.2



### PEBBLEX

	Plain	Wired
Thickness, ins.	$\frac{1}{8}, \frac{3}{16}, \frac{1}{4}$	$\frac{1}{4}$
Max. width, ins.	48	48
Max. length, ins.	132, 136	144
Approx. wt., lbs. per sq. ft.	$2, 2\frac{3}{4}, 3\frac{1}{2}$	$3\frac{3}{4}$
Approx. light trans., %	79.7	69.7

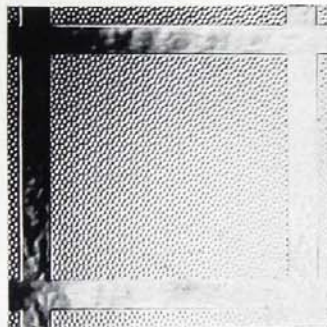

### TRANSEX

Illustration  $\frac{1}{5}$  Full size

	Plain	Wired
Thickness, ins.	approx. $\frac{1}{4}$	
Max. width, ins.	48	
Max. length, ins.	136	not made
Approx. wt., lbs. per sq. ft.	$3\frac{1}{2}$	
Approx. light trans., %	87.6	



### VELVEX

	Plain	Wired
Thickness, ins.	$\frac{1}{8}, \frac{3}{16}, \frac{1}{4}$	$\frac{1}{4}$
Max. width, ins.	48	48
Max. length, ins.	132, 136	144
Approx. wt., lbs. per sq. ft.	$2, 2\frac{3}{4}, 3\frac{1}{2}$	$3\frac{3}{4}$
Approx. light trans., %	89.0	79.0



### DIFFUSEX

	Plain	Wired
Thickness, ins.	$\frac{1}{8}, \frac{3}{16}, \frac{1}{4}$	$\frac{1}{4}$
Max. width, ins.	48	48
Max. length, ins.	132, 136	144
Approx. wt., lbs. per sq. ft.	$2, 2\frac{3}{4}, 3\frac{1}{2}$	$3\frac{3}{4}$
Approx. light trans., %	87.6	77.6

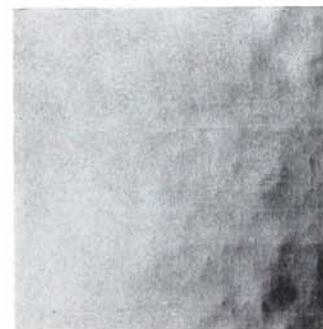

### LUMINEX

	Plain	Wired
Thickness, ins.	$\frac{1}{8}, \frac{3}{16}, \frac{1}{4}$	$\frac{1}{4}$
Max. width, ins.	48	48
Max. length, ins.	132, 136	144
Approx. wt., lbs. per sq. ft.	$2, 2\frac{3}{4}, 3\frac{1}{2}$	$3\frac{3}{4}$
Approx. light trans., %	88.4	78.4

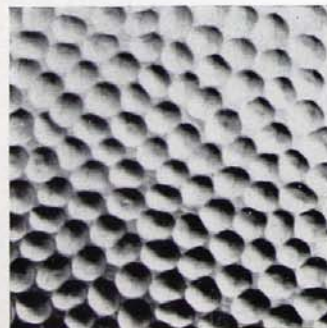

### HAMMERED

	Plain	Wired
Thickness, ins.	$\frac{1}{8}, \frac{3}{16}, \frac{1}{4}$ $\frac{3}{8}, \frac{1}{2}$	$\frac{1}{4}, \frac{3}{8}, \frac{1}{2}$
Max. width, ins.	48	48
Max. length, ins.	90, 132, 136	90, 144
Approx. wt., lbs. per sq. ft.	$2, 2\frac{3}{4}, 3\frac{1}{2}$ $5, 6\frac{3}{4}$	$3\frac{3}{4}, 5, 8$
Approx. light trans., %	90.0	80.0



### FLOREX

	Plain	Wired
Thickness, ins.	$\frac{1}{8}, \frac{3}{16}, \frac{1}{4}$	$\frac{1}{4}$
Max. width, ins.	48	48
Max. length, ins.	132, 136	144
Approx. wt., lbs. per sq. ft.	$2, 2\frac{3}{4}, 3\frac{1}{2}$	$3\frac{3}{4}$
Approx. light trans., %	86.2	76.2



# AKLO HEAT-ABSORBING GLASS

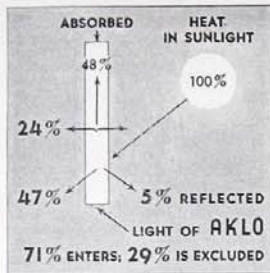

**A** KLO Plate Glass is a product of special chemical composition which absorbs most of the infra-red rays of the sun and consequently lessens the transmission of solar heat. Although similar to standard types of plate glass in appearance and most physical

characteristics, Aklo has a factor of light transmission 12% lower than that of ordinary glass. Its resistance to heat transmission is almost three times greater than that of ordinary glass and its coefficient of expansion only half as great.

These characteristics suggest a number of uses in many types of buildings—a list that is rapidly increasing as the use of glass becomes more widespread in modern structures. Among the most important current uses of Aklo are:

1. To provide cooler, or more even temperatures in rooms or enclosed porches of residences with windows constantly exposed to direct rays of the sun.
2. For reducing damage to perishable goods exposed in storefront display areas.
3. To reduce costly fading of colors in displays that are affected by solar heat rays.
4. To maintain more equable temperatures in refrigerated show windows exposed to the sun.
5. To increase comfort in offices by reducing both glare and sun-heat.

6. To reduce summer heat-gain in buildings having skylights with single or double glazing.

The diagram at the left graphically illustrates the characteristics of Aklo glass. The polished surface of the glass reflects 5% of the sun's radiant heat. Half of the remainder, or 48%, is absorbed by Aklo. The balance, 47%, enters the room immediately. The 48% which is absorbed is dissipated equally by both sides of the glass, so that 24% of it enters the room. Consequently, 71% of the sun's heat enters the room through Aklo glass, and 29% is excluded.

In the table are listed the comparative performance of Aklo and ordinary glass in respect to light and heat transmission under various conditions of use. Comparative figures for Maximum Temperature Difference between Interior and Exterior were recorded as a result of laboratory experiments. Actual temperature difference in buildings will vary with the area of exposed glass, the volume of the room and the rate of heat loss from the room itself.

Aklo has a high resistance to thermal shock due to its low coefficient of expansion. This permits the use of large lights which might otherwise be fractured by cooling action of sudden shadows on hot days.

Standard thicknesses of Aklo Plate Glass are  $\frac{1}{8}$  and  $\frac{1}{4}$  inch. Sheets in  $\frac{1}{4}$  inch thickness are available in any dimensions under a maximum of 128 x 284 inches. Standard thickness for glazing purposes is  $\frac{1}{4}$  inch, but this may vary from  $\frac{3}{32}$  to  $\frac{5}{16}$  inch.

Tolerances and variations in thicknesses are identical for Aklo Plate Glass and standard plate glass. For a full description, refer to table on page 59.

FIGURES IN THIS TABLE represent data obtained under laboratory conditions. Values obtained in service may vary with job conditions within reasonable limits.

COMPARATIVE LIGHT and HEAT TRANSMISSION		
Type of Window and Glass	% Visible Light Transmitted	% Total Radiant Heat Excluded
Single Window $\frac{1}{4}$ " PLATE	92	10
Single Window $\frac{1}{4}$ " AKLO	80	29
Double Window $\frac{1}{4}$ " PLATE	85	16
Double Window AKLO and $\frac{1}{4}$ " PLATE	76	41



AKLO protects contents of this florist's window from withering effect of solar heat



# L. O. F. POLISHED PLATE GLASS

L. O. F. Polished Plate Glass is manufactured in plants equipped throughout with the finest, most modern equipment and of raw materials of the highest quality. It is characterized by brilliance, clarity and sparkling luster, the result of grinding and polishing by highly accurate machines. Grinding removes surface inequalities and polishing, which is done by felt-covered rotating discs, imparts a high luster. Each light of glass is carefully inspected and graded before receiving the L.O.F. label.

The very finest polished plate glass, which is used almost exclusively in making the costliest mirrors, is known as "First Silvering" quality. It is never specified for building purposes because of its high cost. The next quality is "Second Silvering," often used for high grade glazing work; it is seldom specified in sizes over 20 square feet. Plate glass most commonly used for glazing purposes is "Glazing" quality.

Definite requirements for tolerances in thickness and dimensions are set up by U. S. Government specifications. These are described in the accompanying table together with data on available sizes, weights and colors of L.O.F. Polished Plate Glass.

Polished plate glass, clear or in colors, may be subjected to a tempering process to produce Tuf-flex with superior structural properties and high resistance to thermal shock. Vitrolux is also a tempered plate glass product with all the properties that characterize Tuf-flex. In addition, its color is fused to one face during the tempering process. Vitrolux may be opaque or translucent, depending upon the amount of coloring material applied to it.

Clear polished plate glass is available in a range of thicknesses and in standard sheets large enough to meet all average requirements of storefront installations. Sheets larger than those listed below can be obtained, but only on special order. In all cases that involve use of unusually large areas of plate glass, advice of Libbey.Owens.Ford technicians should be sought by the architect before installation is specified.

COLORED plate glass is manufactured by Libbey.Owens.Ford in green, peach and three shades of blue. In all major physical aspects, it is similar to clear plate glass and is characterized by the same luster and clarity. The ability of colored glass to transmit light varies widely in comparison to clear plate, as indicated in the table below.

As an essential material for store windows and display cases, polished plate glass is universally accepted. Contemporary design is rapidly extending its uses in interior decoration as well as architectural design. It is easily cut, ground, etched or painted; it can be curved to a simple radius or formed into a variety of shapes. These possibilities have given plate glass a growing popularity and modern designers are now using it effectively for decorative panels, for shelving, for screens and even for furniture. Architects have recognized it as a building material of both structural and decorative worth and are using both clear and colored plate for interior partitions to control a flow of traffic without obstructing vision, for aquaria, conservatory screens and "picture windows" of unusually large area.

DIMENSIONS and CHARACTERISTICS of L. O. F. PLATE GLASS						
Thicknesses* Available (Inches)	Maximum Dimensions (Inches)	Qualities and Uses	Weights	Colors		
1/8	80 x 126	<b>First Silvering Quality</b> for use in very finest mirrors; not used for building purposes  <b>Second Silvering Quality</b> for use in mirrors and high-grade glazing in sizes not exceeding 20 sq. ft.  <b>Glazing Quality</b> for all glazing purposes	Approximate weight of L.O.F. Plate Glass in pounds per square foot may be derived from the following rule: Weight = 1.62 ± lbs. per square foot per 1/8" of thickness	L.O.F. Polished Plate Glass is available in rich deep tones of: Green, Peach, Blues ranging from pale to deep		
13/64	126 x 274					
1/4	126 x 274			<b>Efficiency of Light Transmission</b>		
3/8	126 x 274			Glass	% Total Light Transmitted	% Transmitted Compared with Clear Plate
1/2	126 x 274			Standard Blue	56	62
5/8	126 x 250			Medium Blue	43	47
3/4	126 x 215			Dark Blue	5.5	6
** 7/32	126 x 274	Standard Green	57	63		
*Tolerance: "Max. and min. should not exceed given thickness ± 1/2 difference between standard thicknesses; for lights under 1/4" thickness and 10 sq. ft., variation (thickness) should not exceed 1/32"; for lights over 1/4" thickness, not more than 1/2 total tolerance for that thickness" - U. S. Gov't. Standard  **Colored Plate Glass		Peach	81	89		
		Clear Plate	92	100		



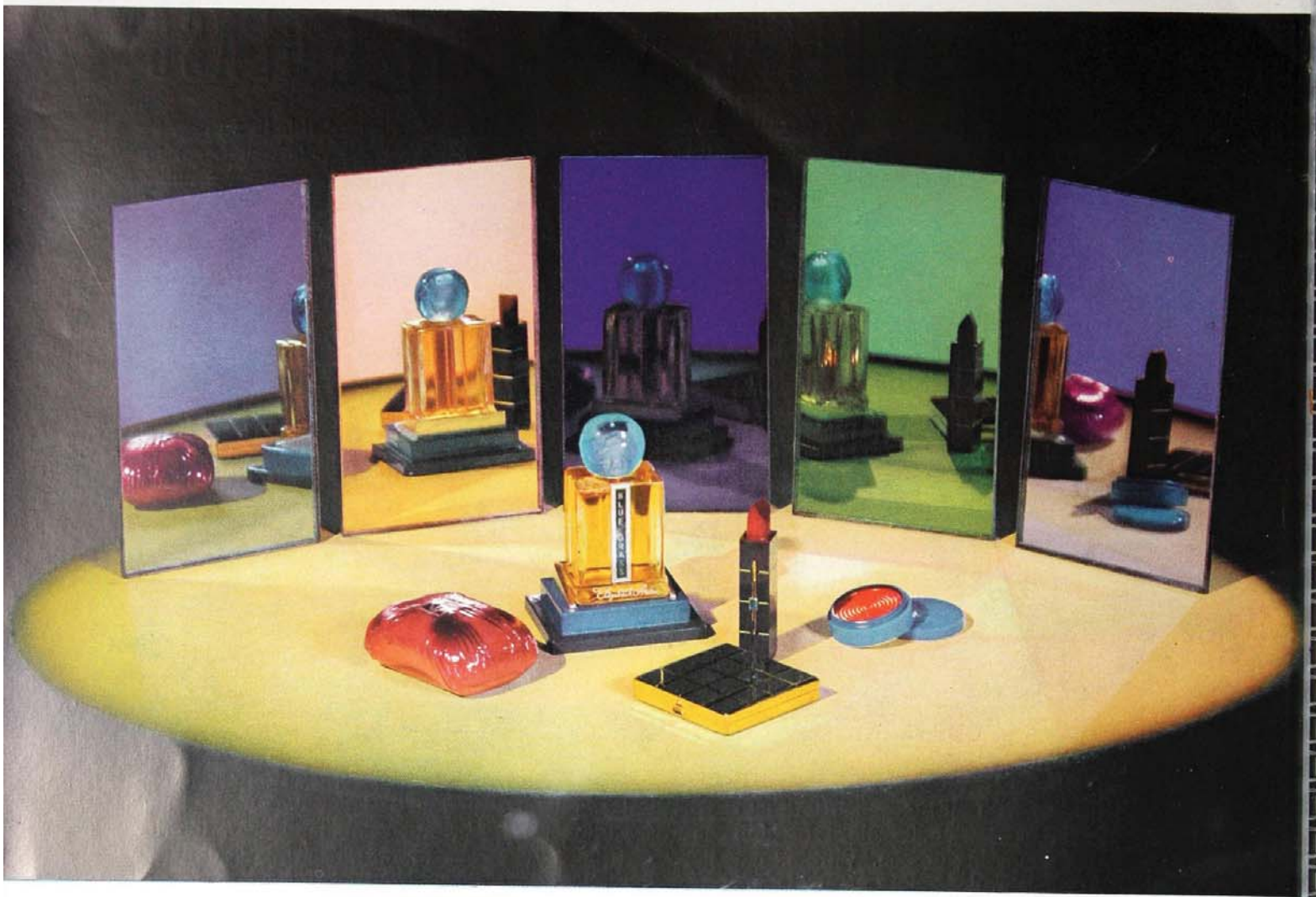

## MIRRORS OF POLISHED PLATE— A COLORFUL BUILDING MATERIAL

THROUGHOUT history mirrors have had important uses as accessories in the fields of architectural and decorative design. But only until modern industrial science standardized the quality of mirrored glass and made it easily available in large areas could mirror be generally regarded as a practical, widely adaptable modern building material.

Today L.O.F. Mirrors of Polished Plate Glass have a wide field of application as a facing material on both exteriors and interiors of all types of buildings. Particularly on storefronts mirror surfaces can contribute unusual color and an attractive and unique quality of brilliant lustre that are not to be found among other materials commonly used as finishes on storefronts.

In show windows mirrors are being

used more and more as coverings for columns to give an illusion of a continuous display and also as panels at the sides of show windows to create an impression of an enlarged display area. In store interiors large areas of mirror serve a valuable purpose in producing a sense of greater height and floor area.

Because mirrors are subject to so many applications and decorative treatments their use is virtually limited only by the imagination of the designer. Mirrors of polished plate glass can be etched, sandblasted or painted. A wide range of color combinations is possible, for L.O.F. mirrors are available in green, peach, pale, medium and deep blue as well as in clear glass with the customary silver backing. Metallic backings of copper, various shades of bronze or of



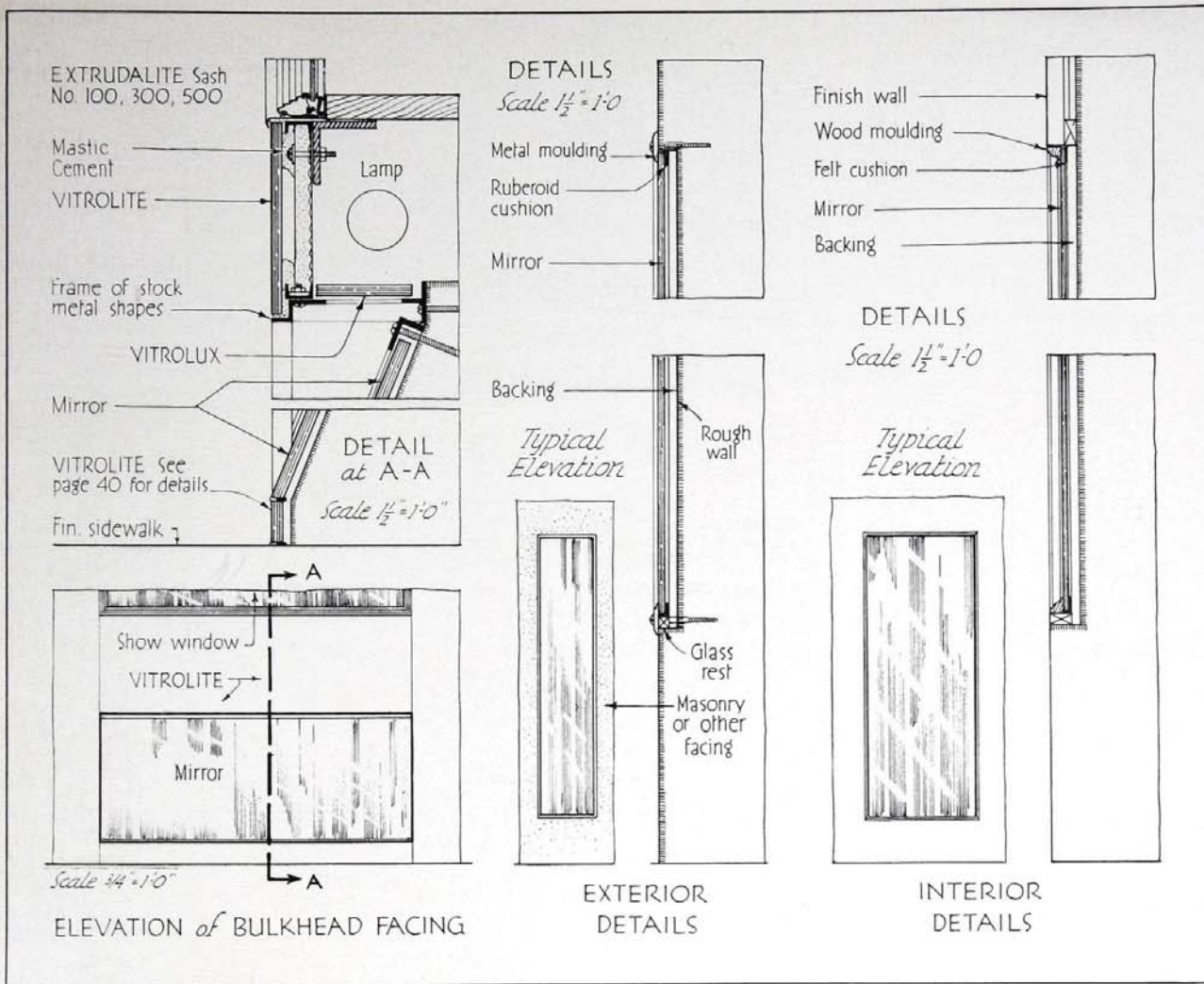

aluminum can be obtained for mirrors of either clear or colored glass on order. It is advisable to consult an L.O.F. technician before specifying the use of mirrors with backings other than standard.

L.O.F. Polished Plate Glass for mirrors is characterized by brilliance, lustre and freedom from imperfections. To conserve these qualities completely, silvering or the application of any metallic backing should be done in a manner approved by the Mirror Manufacturers Association of America and guaranteed for a year from date of manufacture unless installation subjects the mirror to unusually severe conditions of weather, building moisture or continual strong sunlight. The Association has adopted standards of quality and performance for the guidance of both the manufacturer and the user of mirrors. These standards should be followed generally by designers who plan to use mirrors in the development of any type of storefront.

Ways of using L.O.F. Mirrors that embody approved methods of installation are suggested in the drawings above. Tabular data below lists the available sizes and colors of L.O.F. Mirrors and outlines grading standards adopted by the Mirror Manufacturers Association of America.

#### SELECTION DATA FOR L.O.F. MIRRORS

Thicknesses	Colors	Sizes Available	Qualities and Descriptions
Thicknesses of clear mirrors are the same as standard clear plate glass thicknesses. Colored mirrors are uniformly $\frac{7}{32}$ " thick  Tolerances in thicknesses should not exceed $\pm \frac{1}{32}$ "	Clear	Any size in all standard plate glass thicknesses up to 126" x 144"  Areas greater than this can be obtained only on special order	<b>AA Quality:</b> Entirely free from major defects and as nearly perfect as possible. May contain only well-distributed fine seed and small, faint hair lines  <b>A Quality:</b> Central area free from major defects; may contain scattered seed and hair lines  <b>No. 1 Quality:</b> Central area may contain scattered seed and hair lines; outer area may contain short scratches and strings  <b>No. 2 Quality:</b> May contain scattered seed, light reams, strings, light scratches, short finish, hair lines and bullseye visible only from back
	Peach		
	Green		
	Light Blue		
	Medium Blue		
	Dark Blue		
	Metallic backings are available in both clear and colored mirrors		





## LIBBEY. OWENS. FORD COMPLETE STOREFRONT SERVICE

TO ALL those who own, design or build storefronts, Libbey.Owens.Ford offers without obligation an Advisory Architectural Service.

It is not the intention of the trained technicians who compose this group to take the place of the architect or designer. Rather, their wide experience with various types of display and application enables them to suggest improvements in layouts and economies in construction details and to serve as a source of technical information.

Libbey.Owens.Ford makes all necessary facing materials and metals to compose a complete modern storefront for any type of business. The designer, working for attractive display, may give free rein to his imagination. His skill will be supported—on request—by the advice and counsel of men in the L.O.F. Advisory Architectural Service who are familiar with every construction detail, who can supply special parts where necessary, suggest unusual uses and work out application problems.

That design may have full expression . . . that every step be properly coordinated . . . that the finished result shall stand as a creditable accomplishment for all concerned; is the object of the Advisory Architectural Service division. Representatives are available in all sections of the country whom architects, designers, builders, owners and storefront managers may call upon for information and advice regarding any phase of the Libbey.Owens.Ford Complete Storefront Service.



# WHERE TO BUY LIBBEY • OWENS • FORD STOREFRONT PRODUCTS



**B**EHIND all the products that go into the L.O.F. Complete Storefronts stands an industrial and distributing organization with facilities

that make all L.O.F. products easily available in every section of the country.

In eight modern factories, scientific research and manufacturing ability work hand in hand to preserve present standards and forge ahead to new frontiers of development.

From start to finish there is no compromise with quality. Inspection checks every step of the way to the end that every process and product may meet the rigid standards L.O.F. has set. The result is that L.O.F. quality finds expression in storefronts that attract the eye and in storefront materials that will properly and practicably suit the purposes for which they are intended.

Supporting this manufacturing ability is a service structure that blankets the country. You will find Libbey.Owens.Ford distributors located at strategic points to make L.O.F. complete storefronts quickly available.

More than this, you will find that these distributors are composed of men—selected because of their ability and knowledge of all technical and practical phases of application. These men are qualified to act in an advisory capacity to help architects, owners or builders.

In convenient central locations these distributors maintain warehouses for prompt shipment. Every distributor carries adequate stocks for L.O.F. complete storefronts to meet normal requirements quickly and efficiently. These distributors are in a position to sell, fabricate and install complete L.O.F. storefronts. Many of them maintain a free advisory service to architects as an aid to the economical planning and construction of structures in which L.O.F. products are to be used.

## COUNSEL AND RECOMMENDATIONS

**I**NQUIRIES regarding the use of Extrudalite or any one of the Libbey.Owens.Ford Glass products will receive the quick attention of a trained Libbey.Owens.Ford representative. He will be competent to answer almost any question which may arise on the technicalities of using these Libbey.Owens.Ford products. His job, however, is by no means to supplant the architect in the eyes of the owner; or to tell the architect how to design a structure. But he has been trained in the characteristics of the products which he represents; is completely familiar with the Company's policies of sales and distribution; and can often give valuable help to the designer in terms of practical information on the structural possibilities and limitations of Libbey.Owens.Ford products.

It goes without saying that there is no charge for the services of these sales engineers. If some unusual design brings about a condition which requires the specialized knowledge of Libbey.Owens.Ford technicians for its practical solution, these sales representatives will be glad to see that your query is referred to the proper individual for a complete and authoritative recommendation.

## SPECIAL PRODUCTS ON ORDER

**I**F THE DESIGN involves Extrudalite or glass of any special form or pattern, the experienced opinion of Libbey.Owens.Ford technicians should be sought before the design is completed and plans for its construction well advanced. L.O.F. materials have many possibilities for such special adaptations, yet constructions other than those that meet common requirements of recommended good practice should be tested prior to their adoption.

Immediately upon receipt of the necessary information on special forms or patterns, Libbey.Owens.Ford technicians will study the possibilities of developing the product or construction desired. As soon as possible thereafter, they will forward to



you the full information and cost figures covering the development of these special designs. If in their estimation, the idea would prove impractical or too costly to construct, they will suggest other ways to accomplish as nearly as possible the desired result.

### THE EXTENSIVE USE OF GLASS AND METAL

**A**LTHOUGH this book has stressed the use of Extrudalite and Libbey-Owens-Ford Glass products primarily in the field of storefront planning and construction, metal and glass products find an extremely wide range of application in every type of building and, to varying degrees, are applicable to every type of architectural design. This is particularly true of such materials as plate glass and mirrors, colorful Vitrolite and Vitrolux. All these, including

L.O.F. Flat-drawn Glass, are particularly adapted to the residential field and will find application in a variety of ways in every room of the house. Kitchens and bathrooms of Vitrolite; picture windows glazed with plate glass or held in Extrudalite Sash; luminous panels of glowing colorful Vitrolux — all these are applications to which the progressive designer and the modern owner will be immediately attracted.

Use of these products with all their stimulating potentialities for the utilization of both color and light are suggested for theaters, for store interiors as well as exteriors and also for the development of unusual office buildings, commercial and industrial structures. Information on such fields of application for all L.O.F. products will be gladly furnished by a qualified Libbey-Owens-Ford representative or upon application to any dealer or distributor close at hand.

## LIBBEY · OWENS · FORD FACTORIES

Toledo, Ohio  
 Rossford, Ohio  
 Charleston, W. Va.  
 Parkersburg, W. Va.  
 Ottawa, Ill.  
 Shreveport, La.

## L. O. F. DISTRICT SALES OFFICES

New York	Detroit
Boston	Shreveport
Atlanta	Buffalo
Minneapolis	San Francisco
Milwaukee	Los Angeles
Chicago	Cincinnati
Philadelphia	Seattle
Kansas City	Richmond
Denver	Syracuse

**LIBBEY · OWENS · FORD GLASS COMPANY**  
 NICHOLAS BUILDING : : : TOLEDO, OHIO





[BLANK PAGE]



CCA



**LIBBEY · OWENS · FORD  
GLASS COMPANY**



**TOLEDO, OHIO**