

HISTORIC AMERICAN BUILDINGS SURVEY

HOUSE OF TOMORROW

DAHP No. pending

Location: 4907 66th Avenue E, Puyallup, Pierce County, Washington
(formerly 4907 Clarks Creek Road).

Present Owner: Jeremy Shuler and Maureen J. Shuler.

Present Use: Residence.

Significance: The House of Tomorrow property at Clarks Creek is significant as the work and primary residence of Bert Smyser, window display designer and amateur architectural designer. The house is reflective of Smyser's design sensibilities that are present on other buildings he designed and showcases modern materials and his preference for curves and a streamlined aesthetic over straight or hard edges. The house's Streamline Moderne design, both when it was built and today, stands in stark contrast to its surrounding environment. Although Smyser designed several buildings—his own residence, his workshop and office for Smyser Display Service (later a motel, ca. 1927, 2016 S Tacoma Way, Tacoma) Century Ballroom (1934, destroyed by fire in 1964), Bob's Java Jive (2102 S Tacoma Way, Tacoma, 1929), and Exposition Hall (1616 E 26th Street, Tacoma, 1940)—his primary career was as a display designer, and his work ranged from window displays to parade floats and large-scale exhibition designs at world's fairs representing Washington State.

Historian: Katie Pratt, MSHP, Northwest Vernacular, Inc.
Spencer Howard, MSHP, Northwest Vernacular, Inc.

PART I: HISTORICAL INFORMATION

A. Physical History:

1. Date of erection:

The House of Tomorrow was completed in 1941.¹

2. Architect, builders:

Bert Smyser (1893–1987) is the designer of the house. Research did not reveal any original drawings for the house, building permits, or information on the house's builder. The life and career of Smyser are summarized under Part I. B. Historical Context.

3. Original and subsequent owners:

According to documentation from the current owner, newspaper articles, census records, and Pierce County Assessor and Auditor records, the first occupants of the House of Tomorrow were Bert and Helen Smyser. Helen's mother, Laura Svenson, was the owner of the property.² However, the Smysers and Svensons were not the first owners of the property on which they built the House of Tomorrow.

The House of Tomorrow is located within the NE quarter of Section 19 in Township 20 North Range 4 East, Willamette Meridian. All of Section 19 is within the boundaries of the Puyallup Indian Reservation, which was created through an 1857 presidential executive order.

The House of Tomorrow is located on the Milton Fisher allotment, assigned to him by the U.S. Government on January 13, 1886.³ Fisher was an enrolled member of the Puyallup Tribe of Indians.⁴ Fisher's allotment included the NW ¼ of the NE ¼ plus Lot 2 in Section 19 of

¹ "House of Tomorrow," *The News Tribune*, March 6, 1941: 6.

² Pierce County, Washington, Deed Record Book: No. 438: 603, Milton Fisher and Puyallup Indian Commission & August Svenson, September 15, 1920; Pierce County Auditor, Tacoma, Washington.

³ Bureau of Land Management-General Land Office (BLM-GLO), General Land Office Records, "Patent CDI Doc 1644445," digital images, https://gloreCORDS.blm.gov/details/cdi/default.aspx?doc_id=1644445&sid=04kgt5iv.ea (accessed November 2, 2022), Milton Fisher (Pierce County, Washington).

⁴ *Ibid.*

Township 20 North Range 4 East, totaling 58 acres (the amount of the allotment's acreage varied in subsequent accounts).⁵

It appears the House of Tomorrow was built on the Milton Fisher allotment. An 1892 allotment map of the Puyallup Indian Reservation shows only Milton Fisher as the owner of the NW and NE quarters of the NE quarter of Section 19.⁶ Fisher's allotment included the confluence of Clarks Creek and the Puyallup River.

Fisher died in early 1887. His will—supposedly the first will of a Native American filed in probate court in Washington Territory according to an 1887 article in the *Daily Ledger*—indicated his wish for his property (identified as only 40 acres, but later as 80 acres in an 1895 article) to revert to his brother, sister, and cousin.⁷ Indian Agent Myron Eells drew up and witnessed the will before Fisher's death. However, the U.S. Government retained the authority to sell or transfer allotments. Ultimately, the land was divided equally between four heirs of Fisher, including Mrs. Charles Henry and Charles Wilton.⁸

In 1895, however, over 8 years after his death, it appears that Fisher's land (or at least part of it) was included in a public auction of reservation land held by the Puyallup Indian Commission. A man claiming to be Fisher's father sought to sell the land through the Puyallup Indian Commission. This was in contradiction to Mrs. Charles Henry desiring to sell her inherited 20 acres to William A. Berry.⁹

Portions of Fisher's allotment were acquired by non-Native individuals. August Svenson/Swenson and Andrew Anderson in 1895 and 1897, respectively (August's last name is spelled both ways in various deed and census records but Swenson appears to be the Americanized version of the Swedish Svenson). Both acquired their property through sales managed by the Puyallup Indian Commission. Records of Svenson's purchase explicitly state this, while records of Anderson's purchase reference a deed executed by John W. Renfroe and James J. Anderson,

⁵ The Government Land Office Records for Fisher's patent indicate that "Lot 2" is located in the NE quarter of the NE quarter in Section 19 Township 20 Range 4E.

⁶ United States, Puyallup Indian Commission, "Map of the Puyallup Indian Reservation Washington," (Government Printing Office: Washington, 1892), <https://content.libraries.wsu.edu/digital/collection/maps/id/219/> (accessed December 5, 2022).

⁷ "An Indian's Will," *The Daily Ledger*, September 7, 1887: 5; "Land sales not very large," *The Daily Ledger*, May 3, 1895: 3.

⁸ "Land sales not very large," *The Daily Ledger*, May 3, 1895: 3.

⁹ Ibid.

Trustees and Commissioners.¹⁰ Renfroe and Anderson were both commissioners of the Puyallup Indian Commission.

The tract of land purchased by August Svenson in 1895 is west of and across the street from the location where the House of Tomorrow was later built by August's stepdaughter Helen and her husband, Bert Smyser. Svenson's purchase of that land was not recorded with Pierce County until 1920. In 1903 August Svenson acquired an additional 70-acre tract of land to the north from Swan J. Swanson for \$1,000.¹¹

Andrew Anderson acquired a tract of the Fisher allotment, specified as Lot 2 in Section 19, in May 1897, located directly east of the lot acquired by Svenson. In 1919, Andrew Anderson and his wife, Eva M. Anderson, conveyed a portion of Anderson's property; the record does not indicate to whom the land was conveyed, but a record reflecting that transaction was filed in 1929 at the request of August Svenson's widowed wife, Laura Svenson.¹²

In 1929, Laura Svenson purchased a portion of Fisher's Lot 2 from Mike (Mathaj/Mathias) and Gertrude Picha and filed a recorded affidavit that the Anderson tract of land had been rightfully acquired in 1897. It is unclear when the Pichas purchased this portion of Lot 2. The Pichas operated a family farm at the southwest corner of 66th Avenue E and 52nd Street E, southwest of the House of Tomorrow property. The farm is still in operation as of 2022.

Based on the above 1919 and 1929 transactions, it appears that one of these resulted in August and Laura Svenson acquiring the property upon which the House of Tomorrow would be constructed.

After Laura Svenson took ownership of the property, her daughter Helen Frick planted a small ivy plant along the Clarks Creek bank in 1934; the plant was a transplant gifted to her during a trip to Mount Vernon, which then invaded up and down the riverbanks.¹³ In 1940, Helen married Bert Smyser shortly after his divorce from his first wife, Velma, was finalized. Smyser then built the House of Tomorrow in 1941 on the property owned by his new mother-in-law, Laura Svenson. On December 29, 1944, Laura Svenson signed a quit claim deed to the property, gifting ownership of the

¹⁰ Pierce County, Washington, Deed Record Book: No. 438: 603, Milton Fisher and Puyallup Indian Commission & August Svenson, September 15, 1920; Pierce County Auditor, Tacoma, Washington; Pierce County, Washington, Deed Record Book: No. 514: 311, Andrew and Eva Anderson, May 17, 1929; Pierce County Auditor, Tacoma, Washington.

¹¹ "Real Estate Transfers," *The Daily Ledger*, July 31, 1903: 11.

¹² Pierce County, Washington, Deed Record Book: No. 438: 603, Milton Fisher and Puyallup Indian Commission & August Svenson, September 15, 1920; Pierce County Auditor, Tacoma, Washington.

¹³ "Tiny Plant Soars into Alder Tree," *The News Tribune*, February 23, 1964: 22.

property to Bert and Helen Smyser for “love and affection” and one dollar.¹⁴

The Smyseres owned the house for the remainder of their lives. Helen died in 1981 and Bert died in 1987. Upon Bert’s death, the House of Tomorrow property was bequeathed to David Smyser the grandson of Bert (son of Allen) in execution of his estate in 1987.¹⁵

In 1989, David Smyser sold the property to Ronald K. and Sandra K. Sheldon, a married couple.¹⁶ The Sheldons lived in the house for the next decade. In 1999, the Sheldons sold the property to Lucas A. Smith and Heidi L. Palmer-Smith.¹⁷ The couple owned the property for the next nine years.

In 2008, Jamison Robert Harris and Jeremy Richard Shuler purchased the property.¹⁸ On September 3, 2015, Harris signed a quit claim deed on the property, conveying the property to Jeremy Richard Shuler and Maureen J. Shuler, Jeremy’s mother.¹⁹ The Shulers continue to own and occupy the House of Tomorrow as of 2022.

4. Workmen and materials suppliers:

The house, billed as the “House of Tomorrow” in a February 14, 1941, feature on its construction in *The Tacoma News Tribune*, was originally slated to be featured during the 1941 Tacoma Better Housing Exposition, organized by Bert Smyser and held at his Exposition Hall.²⁰ However, it was not completed in time for the February 1941 exposition. Instead, it was highlighted during the “Atlantic City Board Walk” event, held at Smyser’s Exposition Hall in March 1941. An article and sketch in

¹⁴ Pierce County, Washington, Deed Record Book: No. 890: 823, Laura A. Svenson and Helen F. Smyser and Bert A. Smyser, December 29, 1944, Pierce County Auditor, Tacoma, Washington.

¹⁵ Pierce County, Washington, Deed Record Book: No. 0437, 0682 (digitized), Allen B. Smyser, Executor of the Estate of Bert A. Smyser, deceased, and David Smyser, June 30, 1987; Pierce County Auditor, Tacoma, Washington.

¹⁶ Pierce County, Washington, Deed Record Book: No. 0564, 0768 (digitized), David A. Smyser to Ronald K. Sheldon and Sandra K. Sheldon, September 1, 1989; Pierce County Auditor, Tacoma, Washington.

¹⁷ Pierce County, Washington, Deeds: Instrument No. 9907260383 (digitized), Ronald K. Sheldon and Sandra K. Sheldon to Lucas A. Smith and Heidi L. Palmer-Smith, July 20, 1999; Pierce County Auditor, Tacoma, Washington.

¹⁸ Pierce County, Washington, Deeds: Instrument No. 200811060198 (digitized), Lucas A. Smith and Heidi L. Palmer-Smith to Jamison Robert Harris and Jeremy Richard Shuler, October 31, 2008; Pierce County Auditor, Tacoma, Washington.

¹⁹ Pierce County, Washington, Deeds: Instrument No. 201509210442 (digitized), Jamison R. Harris to Jeremy R. Shuler and Maureen J. Shuler, September 3, 2015; Pierce County Auditor, Tacoma, Washington.

²⁰ “The House of Tomorrow is Here Today,” *The Tacoma News Tribune*, February 14, 1941: 22-B.

Tacoma's *The News Tribune* identified the firms involved in the construction and furnishing of the home:²¹

Cavanaugh Lumber Company supplied the house's doors and glass brick. Cecil C. Cavanaugh (ca. 1903–1980) founded the lumber company in ca. 1930. A 1931 fire destroyed much of their plant and product, but Cavanaugh rebuilt the lumber plant in 1932 (1423 Puyallup Avenue, Tacoma). The company weathered the Great Depression and World War II years to emerge as a key building supplier in the post-war residential building boom.

Modern Supply Company supplied the house's plumbing materials. Modern Supply Company opened in 1920 as the Mesher Supply Company; the company's name was changed to Modern Supply Co. in 1937. In 1929, Max Rosen became the manager for the company. Under Rosen's leadership, the company enlarged its stocks and merchandise lines, resulting in remodeling of their location at 1344-46 Commerce Street in Tacoma (also known as 1343-35 Broadway).²² In early 1941, the company moved to a new, larger location down the street at 1315 Broadway (demolished).²³

Light Department of the City of Tacoma provided the electric range and hot water heater for the house. The City of Tacoma entered the utility business on July 1, 1893, when it took over ownership of Charles B. Wright's Tacoma Light and Water Company on April 11, 1893, following voter approval of the \$1.75 million deal. City Light was the new department within the city that managed power.²⁴ The City's utilities program became known as Tacoma Public Utilities. In 1998, Tacoma Public Utilities renamed its divisions, and City Light became Tacoma Power.

Graybar Electric Company furnished the electric refrigerator in the house. Graybar Electric Company was founded in Cleveland, Ohio, in 1869 as Gray and Barton. The bulk of the company's original business was in the telegraph industry before they broadened their scope. In 1918, the company arrived in Tacoma and provided seven northwest counties with power poles, insulators, and lamps (both industrial and residential) and eventually many different types of electrical devices from vacuums to

²¹ "House of Tomorrow," *The News Tribune*, March 6, 1941: 6.

²² "Modern Supply Celebrates 10th Anniversary," *The Tacoma Sunday Ledger-News Tribune*, January 15, 1939: 12-A.

²³ "Modern Supply Co. to Move," *The Tacoma News Tribune and Sunday Ledger*, January 5, 1941: 11-A.

²⁴ David Wilma, "Tacoma Public Utilities," *Historylink.org the Online Encyclopedia of Washington State History*, December 16, 2002, <https://www.historylink.org/File/5025> (accessed October 12, 2022).

kitchen mixers. In 1929, Graybar Electric Company employees purchased all the common stock in the company and became the first company of its size to be completely owned and operated by its employees.²⁵

Colotyle Corporation of Seattle provided Colotyle for the house's bathroom and kitchen. Colotyle Corporation was founded in the 1930s by Frank Hobbs (1895–1972). The company manufactured Colotyle, a proprietary enamel-coated hardboard that could be used in place of tile. Colotyle advertised their products as “porcelain-like.” Born in London, England, Hobbs arrived in the U.S. as a boy and spent his childhood in California. He served in the U.S. Army during World War I, and his capacity for invention was utilized during his time in service as manager of the supply depot he created supply bins out of shipping containers, converted a Ford automobile into a small locomotive, and transformed a balloon hoist into a trench digger. After the war, he moved to Seattle and spent time selling used cars and then moved to Everett where he owned a Buick dealership. He formed the Colfonite Company in 1934, which made Masonite wall board. During this period, he began experimenting with applied finishes on hardboard to provide a low-cost alternative to tile. Once Hobbs perfected the product, he opened a factory under the Colotyle Corporation to manufacture the product for use in kitchens and bathrooms.²⁶ A 1939 advertisement for Colotyle in *The Seattle Sunday Times* references the company's use in model homes in Seattle, Bellingham, Los Angeles, Portland, and Everett. It also mentions the “ultra-modern home by Smyser Display Company” in Tacoma.

Washington Hardware Company provided the hardware and kitchen sink cabinet for the house. The Washington Hardware Company was a longtime Tacoma business, founded in the late 1800s. In 1927, the growing company purchased property in downtown Tacoma for a new storefront at 922-24 Pacific Avenue. The company continued to grow and by 1949 had a new wholesale building constructed on Puyallup Avenue while retaining their shop downtown on Pacific Avenue.

W. P. Fuller and Company provided the house's wallpaper and window sash. William Parmer Fuller, a painter and paper hanger, founded a paint business in the Sacramento area in 1851, calling it Fuller and Heather. It moved its operations to San Francisco in 1867 and became Whittier, Fuller and Company. Fuller died in 1890, and then his family bought out the company and renamed it W. P. Fuller and Company in 1894. Following its new incorporation, the company expanded its product line to

²⁵ “Graybar Co. Chief to Visit,” *The Tacoma News Tribune*, August 18, 1955: A-11.

²⁶ Duane Colt Denfeld, PhD, “Seattle inventor and manufacturer Frank Hobbs is awarded army contract for prefabricated Pacific huts on September 6, 1942,” *Historylink.org the Online Encyclopedia of Washington State History*, June 3, 2010, <https://www.historylink.org/File/9430> (accessed October 12, 2022).

include finishing oils and glass and established new offices in several cities including Oakland, Los Angeles, San Diego, Portland, Tacoma, and Seattle.²⁷ In Tacoma, the company maintained a store downtown at 1121 A Street and by the 1950s had a second store at 3301 S Lawrence Street.

Washington Venetian Blind Company provided the venetian blinds for the house. Frank Vulliet, Jr. established the company in the 1930s and by 1937 had grown enough to require a larger headquarters at 1507 Western Avenue in Seattle.²⁸ Frank Vulliet, Jr. was president of the company until his death in October 1940.

Phil H. Burrows Company provided the shrubbery at the house. Philip (Phil) H. Burrows was a landscape gardener who lived in Tacoma. His nursery was located at 3801 6th Avenue in Tacoma.²⁹

Although the house was praised for its use of plywood, no information was provided to the press about who supplied the plywood for the house's construction.

5. Original plans and construction:

Original plans have not been identified for the property. It is possible that Smyser was planning for the House of Tomorrow in 1939 based on a reference to a model home by the Smyser Display Service in a Colotyle advertisement published that year. He was not yet divorced from his first wife, Velma, at the time of that advertisement, so it is unclear if he always intended for the home to be built on the Clarks Creek property as it was owned by the mother of his second wife, Helen (who he wed in 1940), and he likely would not have known about it or had access to it until his marriage. A rough sketch of the house provided to *The Tacoma News* just days ahead of the Atlantic City Board Walk exhibition where the house was showcased is markedly different than the house that was actually constructed and open to the public, but streamline elements are present on the rough sketch.

6. Alterations and additions:

Alterations have affected the site, building exterior, and interior.

²⁷ Stephen Emerson, "W. P. Fuller and Company Warehouse," National Register of Historic Places nomination (1995), Section 8, Page 4. Available via <https://npgallery.nps.gov/GetAsset/5b424126-b131-46fb-9941-60046d38fdc0> (accessed October 12, 2022).

²⁸ "Venetian Blind at New Location," *The Seattle Sunday Times*, May 30, 1937: 9.

²⁹ R. L. Polk & Co., *Polk's Tacoma City Directory*, Vol. LVIV, (Seattle: R. L. Polk & Co., 1947), 153.

Site changes include:

- Construction of a concrete wall adjacent to the building's south facade,
- Addition of multiple outbuildings in the north yard,
- Added stone veneer as cladding at the exterior fireplace at the fireplace patio,
- Changes in vegetation throughout the site, and
- General overgrowth of vegetation, particularly along the west side of the north yard.

Changes to the building exterior include:

- Siding replacement due to flood damage,
- Replacement of most of the south deck,
- Replacement of most exterior windows with vinyl,
- Replacement of dining room windows and the sliding glass door,
- Replacement of wall sconces at the entrance,
- Installation of a new garage door,
- Enclosure of the sun porch, and
- Reroofing of the building including new parapet flashing.

Interior changes include:

- Painted texture replacing wallpaper,
- New flooring and base in the entry hall, bathroom, and kitchen,
- New curtains for the living and dining room windows,
- New lighting in the dining, kitchen, and bathrooms, and
- New wall finishes at the second-floor bedroom.

B. Historical Context

Early site history, the Puyallup Tribe of Indians and Puyallup Indian Reservation

The land upon which the House of Tomorrow was built is within the ancestral lands of the *s'puyaləpabš* (the Puyallup Tribe of Indians). The *s'puyaləpabš* have lived in and utilized these lands since time immemorial and continue to live and practice traditional lifeways within this area such

as hunting, fishing, and other resource gathering.³⁰ After passage of the Treaty of Medicine Creek in 1854, the U.S. Government created the Puyallup Indian Reservation, which boundaries encompassed the subject property.³¹

The Puyallup are connected in many ways to neighboring Native groups through marriage, shared language, cultural practices, and oral traditions. The traditional language of the Puyallup is the southern dialect of Lushootseed. Traditional Puyallup diet is based on fishing, shellfish harvesting, hunting, and gathering of roots, bulbs, and berries. Traditionally, salmon was not only a dietary staple but also an important trade commodity and source for making other byproduct commodities. Along with Commencement Bay, the Puyallup River and its tributaries are important fishing areas. Traditional fishing techniques for saltwater environments include trolling, long-lining, raking, spearing, harpooning, and seining. Techniques for riverine settings include lift nets associated with weirs, gaffing, falls traps, river seines, and spearing. Berries, roots, and other plants provide additional key components of the traditional diet along with shellfish and select terrestrial and marine animals. A wide variety of plants serve many purposes in traditional practices.³²

The principal Puyallup village site was located near the mouth of the Puyallup River. Other villages included one at the mouth of Clarks Creek where it joins the Puyallup River, near the subject property. The name of

³⁰ Artifacts Consulting, Inc., "Prairie Line Rail Corridor: Historic and Cultural Assessment Report (December 2016), prepared for the City of Tacoma, https://cms.cityoftacoma.org/PLT_Webpage/PLT-Assessment.pdf (accessed November 8, 2022), 18. The Puyallup Tribe of Indians Tribal Historic Preservation Office staff helped write and review the section about the Puyallup Tribe in the Prairie Line assessment.

³¹ United States Government, *Medicine Creek Treaty*, Washington Territory (1854), <https://digitreaties.org/treaties/treaty/12013261/> (accessed November 3, 2022); George W. Maypenny, Commissioner, "Puyallup Reservation, Department of the Interior, Office of Indian Affairs, January 19, 1857," *Executive Orders Relating to Indian Reservations: From May 14, 1855, to July 1, 1912* (Government Printing Office: Washington, D.C., 1912).

³² Puyallup Tribe of Indians, "Puyallup Tribal History," *Puyallup Tribe of Indians*, <http://www.puyallup-tribe.com/ourtribe/> (accessed November 3, 2022); Vi Hilbert, Jay Miller, and Zalmi Zahir, *Puget Sound Geography: Original Manuscript from T. T. Waterman* (Federal Way, WA: Lushootseed Press, 2001); Marian W. Smith, *The Puyallup-Nisqually*, Columbia University Contributions to Anthropology No. 32 (New York: Columbia University Press, 1940); Wayne Suttles and Barbara Lane, "Southern Coast Salish," in *Northwest Coast*, edited by Wayne Suttles, pp. 485-502, *Handbook of North American Indians*, Vol. 7, William C. Sturtevant, general editor (Washington, D.C.: Smithsonian Institution, 1990); Leslie Spier, "Tribal Distribution in Washington. American Anthropological Association General Series," in *Anthropology* No. 3. Menasha, WI: George Banta, 1936; Herbert C. Taylor, Jr., "Anthropological Investigation of the Medicine Creek Tribes," in *Coast Salish and Western Washington Indians II*, edited by David Horr, pp. 401-473, *American Indian Ethnohistory: Indians of the Northwest*, originally presented before the Indian Claims Commission, Docket No. 234, Defense Exhibit No. 129, 1953. New York: Garland, 1974. Harlan I. Smith, *Archaeology of the Gulf and Puget Sound*, the Jesup North Pacific Expedition, Memoir of the American Museum of Natural History, New York, Volume II, Part VI. E.J. Brill, Ltd., Leiden, and G. E. Stechert, New York. 1907; Barbara Lane, "Anthropological Report on the Identity, Treaty Status and Fisheries of the Puyallup Tribe of Indians," prepared for the U.S. Department of the Interior and the Puyallup Indian Tribe (1975), on file ESA, Seattle, WA.

this village is the same as that of the creek, *tx^wsk^wawq^w* (“raven”), in reference to the birds that nest at the head of the stream.³³

The earliest non-Native people to visit the Puyallup’s ancestral lands were members of expeditions such as the British *Voyage of Discovery* led by Captain George Vancouver in 1792 and later the U.S. Exploring Expedition led by Lieutenant Charles Wilkes. In 1833 the Hudson’s Bay Company established Fort Nisqually to participate in the fur trade industry.³⁴ Following the Oregon Treaty of 1846, which established the boundary between the U.S. and British occupation of the Pacific Northwest, and the U.S. Donation Land Act of 1850, non-Native settlement intensified in the area, including within the fertile Puyallup River Valley.³⁵

The U.S. created the Washington Territory in 1853, and its first territorial governor, Isaac I. Stevens (1818–1862), was charged with establishing treaties between the U.S. and area tribes and bands. The *spuyaləpabš* are signatories to the 1854 Treaty of Medicine Creek. Under this treaty, the U.S. Government established three reservations: the Puyallup, Nisqually, and Squaxin Island Reservations. The reservations were too small and poorly situated to provide proper access to resources. In 1855–1856, the *spuyaləpabš* participated in the Treaty Wars, which were a series of regional wars that spanned Puget Sound and east across the mountains. One outcome of the wars was the renegotiation of the Medicine Creek Treaty in 1856. This led to the expansion of the Puyallup Indian Reservation. However, these reservation boundaries were ultimately short-lived and continually violated over the next several decades.

In 1886, the U.S. Government divided the Puyallup Indian Reservation into 178 allotments that were assigned to *spuyaləpabš* heads of households who were appointed non-Native guardians. This land division was intended to discourage the traditional village structure. It was a precursor to the Dawes Act of 1887, also known as the General Allotment Act, which used the same allotment methods to divide reservation lands across the nation. Under this arrangement, the *spuyaləpabš* lost ownership of a significant amount of the land within the Puyallup Indian Reservation. Those with allotments were not able to freely sell or lease them. The inability to sell or even manage their land freely strained the

³³ Hilbert et al., *Puget Sound Geography*, 246-255; Lane, “Anthropological Report on the Identity, Treaty Status, and Fisheries of the Puyallup Tribe of Indians,” 23.

³⁴ Cecilia S. Carpenter, *Tears of Internment: The Indian History of Fox Island and the Puget Sound Indian War* (Tacoma, WA: Tahoma Research Service, 1996).

³⁵ Historical Research Associates, Inc., “Structure Move Feasibility Determination, Clarks Creek Property Acquisition and House Relocation,” in Feasibility Study for Clarks Creek Property Acquisition and House Relocation (August 2018), prepared by Tetra Tech, prepared for Pierce County Planning & Public Works, 7.

tribe, particularly as their land—close to the burgeoning Tacoma and upon fertile soil—skyrocketed in value.³⁶ There was continual struggle, both collectively and as individuals, to retain their culture and land or change as the surrounding area rapidly developed.

Systematic efforts to shrink the Puyallup Indian Reservation were not unique to the Puyallup Tribe or even Washington. In 1887, Congress passed the Dawes Severalty Act, which focused on breaking up reservation lands held in common ownership by tribal members. This act sought to designate individual ownership of parcels or allotments of land within reservation boundaries. While asserted as an effort to protect the property rights of Native Americans and encourage assimilation primarily through agriculture cultivation, the act and subsequent activities caused immeasurable harm to the tribes and traditional lifeways. Many of the allotments were unsuitable for agriculture and the western concept of farming was not conducive with traditional Puyallup subsistence patterns and economy. Also at this time, the U.S. established Indian boarding schools and forcibly removed children from their families, leading to generational trauma and additional challenges to retaining knowledge of tribal history, language, and cultural practices. Many Puyallup people were unable to farm their land and many allotments were sold to non-Native Americans if tribal members did not accept government requirements for allotment.³⁷ Milton Fisher received an allotment for the property upon which the House of Tomorrow was built when the U.S. Government divided the Puyallup Indian Reservation into allotments in 1886.

In 1893, Congress passed the Indian Appropriations Act, which included an amendment drafted by Washington Representative John L. Wilson called the Puyallup Act of 1893. The Puyallup Act created a three-man commission (Puyallup Indian Commission) to oversee the land sales process. The first order of the Puyallup Land Commission was to sell the majority of the reservation land, thus requiring them to determine the owners of the already-allotted acreage. Once that was sorted and permission was received from the allottees, parcels of land were put up for public auction.³⁸ Proceeds from the land sales were collected by the Puyallup Indian Commission and forwarded to the U.S. Department of the Treasury, which established an escrow account for the sellers. Payments

³⁶ Kurt Kim Schaefer, "The Promise and the Price of Contact: Puyallup Indian Acculturation, Federal Indian Policy and the City of Tacoma, 1832-1909," PhD diss., (University of Washington, 2016), 7.

³⁷ National Archives, "Dawes Act (1887)," *National Archives*, <https://www.archives.gov/milestone-documents/dawes-act> (accessed November 2, 2022).

³⁸ Schaefer, "The Promise and the Price of Contact," 269-271.

were distributed to the sellers in ten annual installments (later five installments in 1894) rather than a lump sum.³⁹

According to historian Kurt Kim Schaefer in their 2016 doctoral dissertation, the Puyallup Act of 1893, “Initiated a fifteen-year process in which the Commencement Bay Indians sold virtually all of their reservation lands but received only a fraction of its value. Consequently, many tribal members became part of diaspora to other locations throughout the region.”⁴⁰ By 1909, most of the 18,000-acre Puyallup Reservation lands were no longer under Puyallup ownership.⁴¹ And by a 1915 edition of Kroll’s Atlas of Pierce County, fewer than a dozen Puyallup families retained ownership of reservation land.⁴²

Development along the Puyallup River and Clarks Creek

The Puyallup River Valley—with its fertile soil and proximity to Tacoma’s deep-water port and (eventual) transcontinental railway terminal—was a draw to non-Native individuals, who moved to the area in earnest by the 1860s. A community formed at the location of today’s city of Puyallup and was first known as “Franklin,” and the first post office was established in 1862. Ezra Meeker and his family arrived that year and established a farm. Other farms sprang up, and an early key crop was hops after Charles Woods brought hops to the region in 1865. The Meekers became hop farmers and platted the townsite of Puyallup in 1877 on 20 acres of his farmland.⁴³ Railroad transportation arrived in Puyallup in 1877 when the Northern Pacific Railway Co. constructed a new line on the south side of the Puyallup River to connect Tacoma with the mines of Wilkeson. The railroad and agricultural growth prompted more farmers to move to the valley and cultivate crops.

Amid this growth, the lands of the Puyallup Indian Reservation became increasingly valuable as they were sited between the agricultural land and the burgeoning city of Tacoma. As noted above, the Dawes Severalty Act of 1887 paved the way for non-tribal ownership of reservation lands, and tribal ownership of the reservation steadily decreased over the next two decades.

³⁹ Ibid, 271.

⁴⁰ Schaefer, 342.

⁴¹ Schaefer, 335.

⁴² Schaefer, 331; Kroll Map Co., “Atlas of Pierce County, Wash., T. 20 N. R 4 E,” (Seattle: Kroll Map Co., 1915), <https://content.libraries.wsu.edu/digital/collection/maps/id/887/rec/27> (accessed October 12, 2022).

⁴³ Historical Research Associates, Inc., “Structure Move Feasibility Determination, Clarks Creek Property Acquisition and House Relocation,” 8.

The hop farming industry was a massive boon to the local economy, bringing a reported \$20 million to the state and employing 15,000 by 1891. However, a hop lice invasion in 1892 decimated the hop crops in the Puyallup River Valley, and farmers turned to different crops like berries and bulbs. The financial Panic of 1893 devastated both the local and national economies, and the timing was also detrimental to the sale prices of Puyallup Indian Reservation land through the Puyallup Act of the same year. The agricultural economy of the Puyallup River Valley began to rebound after the Klondike Gold Rush of 1897 and into the 20th century. The first “Valley Fair” was hosted in Puyallup in 1900, with area farmers able to show off their produce; this fair eventually grew into the Washington State Fair. Agriculture was the clear economic driver for the valley in the early 20th century, with the Puyallup and Sumner Fruitgrowers’ Association boasting 1,300 members and its cannery preserving nearly 3 million pounds of produce by 1912.⁴⁴

The Puyallup River (*spuyaləp stuləkʷ*), a glacial-fed river and the largest in the Puyallup River watershed, was originally a meandering river. As settlement and development increased in the Puyallup River Valley—with farms, residences, and communities established in the river’s floodplain—frequent log jams, mudslides, and flooding negatively impacted residents. A project was undertaken to deal with the flooding issues of the Puyallup, White, and Stuck rivers. Pierce County and King County established the Inter-County River Improvement District (ICRI) in 1914. While King County paid for most of the work, the ICRI straightened the Puyallup River channel between 1914 and 1916.⁴⁵ Agricultural activity increased in the area during World War I, but then decreased again during the Great Depression.

Despite the work in the 1910s, flooding persisted in the region. Another agency, the Pierce County River Improvement agency (PCRI), continued efforts to stabilize rivers in the Puyallup River Valley, adding wood bulkheads and debris barriers in the 1920s and 1930s. Additional levees were constructed over the next few decades. The U.S. Army Corps of Engineers and its contractors worked to build the Mud Mountain Dam on the upper White River in the late 1930s and into the 1940s to control the floodwaters of the White and Puyallup rivers. Although the project was approved by the 1936 Flood Control Act, the dam was not completed until 1948.

Other changes in the Puyallup River Valley in the early 20th century included improved transportation connections. The portion of State Route

⁴⁴ Historical Research Associates, Inc., “Structure Move Feasibility Determination, Clarks Creek Property Acquisition and House Relocation,”9.

⁴⁵ Ibid.

(SR) 167 or River Road, which runs just north of the House of Tomorrow property along the south side of the Puyallup River, was incorporated within the state highway system in 1931 as part of State Road No. 5.⁴⁶ As a state road, the state appropriated funds to improve and maintain the road and ensured it was an important transportation link between Tacoma and the Puyallup River Valley and beyond. Formal grand opening ceremonies for the stretch of highway on the Puyallup River's south bank were held in July 1936.⁴⁷

The Puyallup River Valley began to recover from the Great Depression in the late 1930s and into the early 1940s with the production ramp-up for World War II. It was in this period that Bert Smyser constructed the House of Tomorrow at Clarks Creek on the south side of the channelized Puyallup River near the Puyallup River Bridge (George Milroy Bridge, built 1931). A 1941 U.S. Geological Survey (USGS) aerial photograph of the surrounding area depicts the Puyallup River straightened and Clarks Creek flowing into the Puyallup River along its current route. The House of Tomorrow was also constructed at its present site in the 1941 USGS photograph, along with other surrounding buildings and structures and agricultural land.

During the years of World War II, defense production ramped up in the surrounding region, including the greater Puyallup area. After Japan's bombing of Pearl Harbor on December 7, 1941, President Franklin D. Roosevelt signed Executive Order 9066, which authorized the forced removal and incarceration of persons of Japanese descent—immigrants (Issei) and American citizens (Nisei)—from the west coast.⁴⁸ The grounds of the Washington State Fair were used as a detention center (Puyallup Assembly Center/Camp Harmony) where Japanese were held before being sent to incarceration camps during World War II.⁴⁹

After World War II ended, veterans and some Japanese people returned home to Puget Sound, and many workers in the defense industry remained in the area. Prosperity arrived for many with the expansion of

⁴⁶ SRI Foundation, "Washington State's Historic State Roads: Historic Context for Island, Snohomish, King, Pierce, and King Counties," (January 2014), <https://dahp.wa.gov/sites/default/files/Roads%20Historic%20Context.pdf>, (accessed November 10, 2022), 171.

⁴⁷ "Puyallup's Festival Next Week," *The Tacoma Daily Ledger*, July 17, 1936: 14.

⁴⁸ Executive Order 9066: Resulting in the Relocation of Japanese (1942)," *Our Documents*, <https://www.ourdocuments.gov/doc.php?flash=false&doc=74> (accessed May 12, 2021). Information excerpted from Documents from the National Archives: Internment of Japanese Americans (Dubuque, Iowa: Kendall/Hunt Publishing Company, 1989) p. 9–10.

⁴⁹ Louis Fiset, "Camp Harmony (Puyallup Assembly Center), 1942," *Historylink.org the Online Encyclopedia of Washington State History*, October 7, 2008, <https://www.historylink.org/file/8748> (accessed November 8, 2022); Frank Chesley, "Puyallup – Thumbnail History," *Historylink.org the Online Encyclopedia of Washington State History*, January 22, 2008, <https://www.historylink.org/file/8447> (accessed November 8, 2022).

the middle class, particularly with policies like the GI Bill of Rights (1944) providing financial help to veterans seeking to attend college, purchase homes, and buy farms. White Americans benefited most from the upward mobility afforded by these programs. Development of Puyallup and the surrounding area increased, and new housing developments extended into farmland to accommodate this growth during the 1950s. Increased competition, both foreign and domestic, in the berry industry prompted farmers to pursue different crops, including Christmas trees and rhubarb. The bulb (flower) industry, which had gained prominence in the valley in the 1910s, had shifted farther north to the Skagit River Valley. By the mid-1970s, there were consistent efforts in Western Washington to preserve farmland as suburban development continued to encroach.

Bert Smyser

Bert Allen Smyser was born on June 11, 1893, in New Brunswick, New Jersey to parents Charles Smyser and Emma (nee Snyder) Smyser. Shortly after his birth, Smyser's family—including his older brother, Ray—moved westward to the Puget Sound area. Charles found work in cigar manufacturing and traveled through the Northwest selling product.

In the meantime, the youngest Smyser, Bert, grew up in Tacoma. The family rented a house at 1946 S G Street before constructing their own home at 2012 S J Street by 1898. In 1909, at the age of 16, Bert walked into Kennedy Bros. Arcade in downtown and requested a job as a window dresser. He began his career in window and display design there; the 1910 census lists him as a window trimming apprentice.⁵⁰ His window design for Stone-Fisher Co. earned an award for best decorated window by the Tacoma Rose Society's 1913 contest.⁵¹ In August 1913, he traveled to Chicago to attend a window designer's convention, demonstrating the continuation of his education.⁵²

Amid starting his career, Smyser married Velma Arlene Anderson on July 28, 1914 (Velma is unrelated to the Andersons previously listed in the ownership history). Velma was born in 1893 in Tacoma to parents Anton Anderson and Amanda (nee Magnuson) Anderson.⁵³ Shortly before they married, Smyser applied for permits to build a house for himself and his

⁵⁰ U.S. Census Bureau, Twelfth Census of the United States: Tacoma, Pierce County, Washington (1910), Enumeration District 258, Sheet 12A.

⁵¹ "Stone-Fisher Company's Artistic Window Display Wins in Tacoma Rose Society Competition," *The Tacoma Daily Ledger*, June 27, 1913: 4.

⁵² "Society News," *The Daily Ledger*, August 3, 1913: 26, column 2.

⁵³ Washington State Archives, "Death Certificate: Velma A. Mathison, March 29, 1983," Department of Health, Death Certificates, Washington State Digital Archives, <http://digitalarchives.wa.gov> (accessed November 10, 2022).

bride at 2010 S J Street—next door to his childhood residence. It was in this home where the couple welcomed their two children: Allen Smyser (1916–2003) and Arlene Smyser (1917–1934).

Smyser continued his career as a window display designer throughout the 1910s and 1920s. Smyser was appointed chairman of Tacoma's local committee for the Division of Advertising within the federal government's Committee on Public Information (CPI)—as the United States entered World War I, the government called upon window displays to advertise Liberty loans and other government calls to action.⁵⁴ The calling upon of storefront windows to display critical information demonstrated the importance of Smyser's profession. Smyser designed parade floats in addition to window displays. In 1919, he designed the float car for the Tacoma Railway & Power Company in the Pacific Northwest Peace Jubilee's parade.⁵⁵ Between 1920 and 1921, Bert and Velma were able to move their family into a larger home in Tacoma's North End at 3919 N 30th Street.⁵⁶

Smyser won two silver cups in 1924 at the first annual convention of the Pacific Coast Association of Display Men, held in Spokane, Washington. In 1925, as manager of Stone-Fisher's window display department, Smyser won two first-place cash prizes and silver trophy cup at a three-day convention of the Pacific Coast Association of Display Men in Portland, Oregon.⁵⁷ His cash prizes were \$20 for best novelty drape on a wax figure and \$50 for best swimming suit display. He earned the silver trophy cup for his photographic display of window displays from different cities. Smyser was elected the second vice president of the association at the 1925 convention.

Smyser's success had reached a level by 1930 that he opened his own business—Smyser Display Service. The company was headquartered at 2016 S Tacoma Way. He worked on Washington exhibits at the San Francisco and New York world's fairs, even partnering with famed photographer Asahel Curtis to create the displays.⁵⁸ Asahel Curtis also served as vice president of Smyser Display Service when it incorporated in 1937.⁵⁹ Smyser worked on parade floats and even completed a display

⁵⁴ "Named Chairman for Window Displays Here," *The Tacoma Daily Ledger*, December 6, 1918: 9.

⁵⁵ "T. R. & P. Co. Had Novel Float Parade Saturday," *The Tacoma Daily Ledger*, June 10, 1919: 7.

⁵⁶ R. L. Polk & Co., *Polk's Tacoma City Directory, 1920* (Tacoma, WA: R. L. Polk & Co., 1920), 766; R. L. Polk & Co., *Polk's Tacoma City Directory, 1921* (Tacoma, WA: R. L. Polk & Co., 1921), 696.

⁵⁷ "Tacoma Display Man Winner of Prizes, Trophies," *The Tacoma Sunday Ledger*, October 4, 1925: 6-A.

⁵⁸ "Photo-Mural to be Gift," *The News Tribune*, February 3, 1946: 1.

⁵⁹ "Puget Sound Incorporations," *The News Tribune*, July 12, 1937: 3; "Incorporations," *The Seattle Times*, July 12, 1937: 19.

on the uses of plywood for the Harbor Plywood Company of Aberdeen, which toured eastern and southern states.⁶⁰ Smyser also expanded his business ventures during this period. He designed the Coffee Pot Restaurant (later Java Jive, 2102 S Tacoma Way) for Otis G. Button in 1929.⁶¹ He then designed and operated the Century Ballroom (1934, destroyed 1964) in Fife, which hosted musicians for dances as well as expositions and large-scale events.⁶² The Century Ballroom hosted legendary musicians over the years, like Louis Armstrong, Benny Goodman, Nat King Cole, Duke Ellington, Gene Krupa, Roy Acuff, Hank Williams, Lionel Hampton, and Etta James.⁶³

Bert and Velma separated by 1939, and their divorce was finalized May 10, 1940. Before their divorce was finalized, it was an acrimonious split with charges of infidelity levied by Velma against Bert and debates over the division of assets. As news of their divorce hit the papers and the trial started to decide their case, the couple reached a settlement, with Velma receiving \$1,000 in cash, \$75 per month in alimony for three years then \$50 per month for two years, along with their house at 3919 N 30th Street in Tacoma, a property on Chambers Creek, and an insurance policy. Velma relinquished all rights to Bert's company, Smyser Display Service. Amid his divorce from Velma, Smyser continued his professional and business advancement. He purchased an unfinished structure at 26th and E Bay Street by January 4, 1940, in order to complete and enlarge it for use as an indoor sports complex and exhibit space.⁶⁴ The newspaper announcement of the purchase indicated that in early plans Smyser intended to have display space for the Smyser Display Service company in the building, too.⁶⁵

Bert married Helen Frick on June 5, 1940. Helen was born on August 3, 1897, to parents Alfred and Laura (nee Malm) Frick (1871–1961). It is unclear when or how Helen's father died, but the 1900 federal census lists Helen, her mother Laura, and her brother Antone living with Laura's

⁶⁰ "Display Shows Plywood Uses," *The News Tribune*, January 5, 1938: 11.

⁶¹ Tacoma Public Library, "2102 South Tacoma Way, Tacoma," *Tacoma-Pierce County Buildings Index*, <https://cdm17061.contentdm.oclc.org/digital/collection/p17061coll1/id/20209/rec/4> (accessed December 6, 2022).

⁶² "Luxurious Ballroom Will Open," *The Tacoma Daily Ledger*, December 28, 1934: 4.

⁶³ "King of Swing," *The Tacoma News Tribune*, May 19, 1940: A15; "America's Ace Drummer Man," *The Tacoma News Tribune*, ad presenting Gene Krupa, August 30, 1941: 6; "Louis Armstrong," *The Tacoma News Tribune*, May 9, 1942: 10; Tacoma Public Library, "1406 54th Ave E, Fife," *Tacoma-Pierce County Buildings Index*, <https://cdm17061.contentdm.oclc.org/digital/collection/p17061coll1/id/42209/rec/1> (accessed December 6, 2022).

⁶⁴ "Bert Smyser Behind Deal," *The Tacoma Times*, January 4, 1940: 13.

⁶⁵ *Ibid.*

parents, Antone and Edith Malm.⁶⁶ Laura remarried in 1904 to August Svenson (1859–1925) on September 14, 1904.⁶⁷ After their marriage, Laura and her children, including Helen, lived with Svenson who worked as a farmer in Pierce County.

As a young woman, Helen married her first husband, Charles A. McGee, on November 12, 1919. Helen and Charles made their home in Tacoma, where Charles worked as a physical education director at Lincoln High School. By the 1940 census, Helen was listed as a widow and living with her mother; it is not known when or how Charles died.⁶⁸ Helen was identified as the head of the household, but her mother had lived in the same house in 1935 according to the census records, while Helen lived in Tacoma.

Just two months after the marriage of Bert and Helen, tragedy struck Smyser and his company. A large fire almost completely destroyed the Smyser Display Service's building at 2016 S Tacoma Way. The fire, which blazed on August 9, 1940, was fueled by the large quantities of paint and highly combustible materials used by the company in their display and float construction. No one was inside the building during the fire, which started in the furnace room. Damages were assessed at \$30,000.⁶⁹

Shortly after the fire at Smyser Display Service, an announcement published in the local paper on Monday, August 19, 1940, reported that Smyser planned to take out a permit for a \$10,000 renovation on the former ice arena building that he had purchased in January.⁷⁰ The design for the new exposition hall featured Smyser's signature curves.⁷¹ While working on this project, Smyser was also working on the design and construction of a residence for himself and Helen.

It was on property that Helen's family owned—specifically her mother, Laura Svenson—that Bert constructed his "House of Tomorrow."⁷² It was

⁶⁶ U.S. Census Bureau, *Twelfth Census of the United States: Reservation Precinct, Pierce County, Washington* (1900), Enumeration District 150, Sheet 14B.

⁶⁷ Vital Statistics Agency, Victoria, "Canada, British Columbia Marriage Registrations, 1859-1932; 1937-1938," *FamilySearch*, <https://familysearch.org/ark:/61903/3:1:S3HY-6M8G-61?cc=1307718&wc=S6K9-82S%3A9701> (accessed November 1, 2022).

⁶⁸ U.S. Census Bureau, *Sixteenth Census of the United States: Riverside E. Precinct, Pierce County, Washington* (1940), Enumeration District 27-84, Sheet 1B.

⁶⁹ "\$30,000 So. Tacoma Way Fire Draws Thousands," *The Tacoma News Tribune*, August 12, 1940: 1.

⁷⁰ "Permits for Building Take \$37,000 Jump," *The News Tribune*, August 21, 1940: 13.

⁷¹ "New Exposition Building," *The News Tribune*, August 22, 1940: 6.

⁷² There are no records of any real estate transactions for the subject property where Bert Smyser was the grantee prior to 1944. At that time, Helen's mother, Laura Svenson, signed a quit claim deed to the property

his first and only residential project in the streamline style that defined much of his career (he had previously had a small craftsman bungalow built for his family and he had used streamline elements in earlier projects like Century Ballroom). A 1939 Colotyle advertisement in *The Seattle Sunday Times* references a model home by Smyser Display Company in Tacoma; it is unclear if this is the house Smyser would build on the property near Clarks Creek.⁷³

The building was set to be featured at the 1941 Tacoma Better Housing Exposition (held at Smyser's newly renovated ice arena branded as Exposition Hall), but construction delays meant it was not ready for the program. Instead, it was announced during a week-long feature attraction called "Atlantic City Board Walk" at the Exposition Hall—a reproduction of the east coast Atlantic City boardwalk complete with amusement park rides—with tours of the House of Tomorrow available to the public.⁷⁴ The 1941 Tacoma Better Housing Exposition was organized by Smyser but jointly sponsored by The Tacoma News Tribune and the Tacoma Building Industry and held in Smyser's newly refreshed Exposition Hall.⁷⁵ The exposition was designed to allow prospective home builders and buyers to view the latest technologies and trends in building materials and home equipment. Newspaper coverage of the exposition heralded it as the "first big-time housing show in Tacoma."⁷⁶ In addition to all the exhibits, Smyser organized entertainment for visitors, including a floor show backed by the music of Brad Bannon's orchestra, along with dancing. Building expositions, like the 1941 exposition in Tacoma, were intended to promote the building industry and increase business. Vendors varied from contractors, manufacturers of building materials, to banks assisting with home financing.

Smyser had his new residence constructed of plywood to demonstrate the use of the product. A February 14, 1941, feature on the house in *The Tacoma News Tribune* stated, "The House of Tomorrow is here today," and that while there had been much discussion about plywood houses it was up to Smyser "to building one that really looks like our conception of

(identified as Section 19, Township 20, Range 4) in December 1944 (but not recorded until 1948). Pierce County Auditor, "General Index—Grantee," 1947-48, page 341. Available via <https://armsweb.co.pierce.wa.us/IndexBook/QuickSearch.aspx> (accessed October 11, 2022).

⁷³ "Colotyle: Porcelain-like Walls for Modern Homes, *The Seattle Sunday Times*, May 14, 1939: 37.

⁷⁴ "Boardwalk Show Opens," *The Tacoma News Tribune*, March 2, 1941: 11.

⁷⁵ Charles R. Edrington, "Housing Show Will End Run Tonight," *The Tacoma News Tribune*, February 23, 1941: 1, 11-A; Charles R. Edrington, "Realtors Told of Housing Exposition," *The Tacoma News Tribune*, February 9, 1941: 7.

⁷⁶ "Dedicate Exposition Hall and Housing Show," *The Tacoma News Tribune*, February 18, 1941:

what a plywood house should be like.”⁷⁷ Smyser’s design for his new home with Helen showcased the modern elements while keeping convenience and comfort at the forefront. The new house also showcased Smyser’s love of Streamline Moderne, a transitional style from the high style ornate Art Deco of the 1920s and 1930s and the modernist styles of the mid-20th century. Streamline Moderne emerged in the 1930s amid the Great Depression with an emphasis on simpler, streamlined forms and low cost, mass-produced materials.⁷⁸ Key elements of Streamline Moderne are curved corners, smooth surfaces, horizontal elements—all of which are reflected on Smyser’s “House of Tomorrow.” The style gained exposure and prominence during expositions and world’s fairs of the 1930s, including Chicago’s Century of Progress World’s Fair (1933-34), Dallas’ Centennial Exhibition (1936), New York’s World’s Fair (1939-40), and San Francisco Golden Gate International Exposition (1939). Smyser’s career as a display designer, particularly at world’s fairs, would have provided him with plenty of exposure to the style, which he also utilized on his other building designs. Bert and Helen spent the rest of their lives living together at their House of Tomorrow and running Smyser Display Service. Their lives were disrupted, though, when they were indicted for income tax evasion in 1953; it appears the charges against Helen were dropped and Bert pled guilty to a lesser charge (a fine).⁷⁹ Bert was also sentenced to a year in prison, but it is unclear if he served or where.

Bert and Helen hosted friends, family, and guests at their House of Tomorrow home. According to family stories shared with the current owner Jeremy Shuler, the Smysers often hosted some of the musicians who performed at his Century Ballroom property. However, it is unclear how frequently this occurred or who specifically stayed with the Smysers.

It appears the property was enjoyed not only by Bert and Helen, but also their extended family members. Plaques on the property honor various family members, including Bert’s father, Charles H. Smyser (dated August 1, 1948), Helen’s mother Laura “Mother” Svenson (dated November 1, 1942), and Helen’s half-sister and brother-in-law, Leila and Scott Lovejoy (August 15, 1948).

Post-Smyser Ownership

The property was not sold again until after the Smysers’ deaths. Helen died on July 10, 1981, and Bert died on February 14, 1987. Bert’s estate,

⁷⁷ “House of Tomorrow is Here Today,” *The Tacoma News Tribune*.

⁷⁸ City of Long Beach, “4.10, Streamline Moderne: 1934-1945,” Long Beach Historic District *Design Guidelines*, 1, https://www.longbeach.gov/globalassets/lbds/media-library/documents/planning/historic-preservation/districts/guidelines/chapter-4-10_streamline-moderne (accessed December 6, 2022).

⁷⁹ “Pleads Guilt in Tax Trial,” *The News Tribune*, June 23, 1954: 6.

executed by his son, Allen, deeded the property to Bert's grandson and Allen's son, David Smyser. Other property owned by Bert and Helen passed to Allen.

David Smyser then sold the property to Ronald and Sandra Sheldon, who lived there between 1989 and 1999. Ronald married Sandra Johnson (nee Olmsted) in January 1981.⁸⁰ The Sheldons lived in the house for the next decade. They added their own family plaques to the property, including ones commemorating their parents, Kenneth and Irene Sheldon (Ronald's) and Ed and Irene Olmsted (Sandra's), as well as their own children. The Sheldons then sold the property to Lucas A. Smith and Heidi L. Palmer-Smith in 1999. After owning the property for nine years, the Smiths then sold it to Jamison Robert Harris and Jeremy Richard Shuler in 2008. Harris conveyed the property to Shuler, along with Shuler's mother Maureen, in 2015.

Jeremy Shuler continued to occupy the house after ownership was transferred to him and his mother. However, despite dredging and levee construction to stabilize the Puyallup River and surrounding watershed, the House of Tomorrow property experienced consistent flooding from the adjacent Clarks Creek in its lower floors over the years. Between October 2015 and January 2016, alone, Shuler experienced three different flooding incidents. A December 9, 2015, flooding event covered the lower level of the House of Tomorrow in 4 feet of water.⁸¹

Summary

Despite ownership of the house passing out of the Smyser family and damage from persistent flooding, Smyser's "House of Tomorrow" at Clarks Creek reflects his design aesthetic in a residential application. It is a noteworthy example of Streamline Moderne in an otherwise agricultural and residential area.

⁸⁰ "Vital Statistics: Notice of intent to wed," *The News Tribune*, December 31, 1980: B-19; "Marriage License: Ronald K. Sheldon and Sandra Johnson, January 17, 1981," Department of Health, Marriage Certificates, Washington State Archives, Digital Archives, <http://digitalarchives.wa.gov> (accessed November 10, 2022).

⁸¹ Stacia Glenn, "Record-setting year for rain and heat," *The News Tribune*, January 2, 2016: 3A.

PART II: ARCHITECTURAL INFORMATION⁸²

A. General Statement

1. Architectural character:

The House of Tomorrow property provides a notable example of a building shaped by the site topography and the use of sheet goods (plywood and hardboard) as interior finishes in the Puyallup River Valley. The setback from the road with a front lawn and the house's streamline appearance conveys a modest scale and traditional single family home appearance. In contrast, views from the creek convey a complex design integrated into and seeking to capitalize on the scenic qualities of the setting. The building's Streamline Moderne design contrasts with nearby Craftsman influenced farmhouses.

The influence of the site topography and Clarks Creek on the building design is evident in the vertical arrangement of interior floor levels, and the role, type, and placement of windows. Design changes to the site topography in order to create outdoor spaces is evident in the retaining walls with stairways to connect the spaces at differing elevations.

The interior exhibits a skilled use of a variety of sheet good finishes, including stained Douglas fir and mahogany veneer plywood, and enamel-coated hardboard (Colotyle). The use of stepped planes at the ceilings provides additional visual interest and a cohesive design. The use of chrome accents, through moldings and hardware, highlights the enameled hardboard. Continuity between the first-floor spaces is achieved using shallow grooves, horizontal lines, and curved corners.

2. Condition of fabric:

The overall condition of the building in 2022 is fair. Past damage from flooding had been repaired. The exterior envelope including walls, windows, and cladding remains in functional condition. Windows have been replaced with new vinyl units. Interior finishes generally remain in good condition, particularly on the first floor that has experienced fewer alterations. The site exhibits a higher level of condition issues. Retaining walls have extensive cracking in the concrete parging and detail loss is frequent on the plaques embedded in the retaining walls. The concrete slabs at the fireplace patio exhibit extensive cracking and uneven

⁸² Field photographs and field notes were developed following site visits on October 4 and 5, 2022.

settlement. Vegetation is overgrown in the north portion of the site making access beyond the north yard limited.

B. Description of Exterior

1. Overall dimensions:

The house has a generally rectangular 42' x 28' plan oriented lengthwise between and with the back east facade overlooking Clarks Creek and the west facade fronting 66th Avenue E. Portions of the north and west sides of the plan are inset at the front west entrance and the north garage entrance. The outer corners of the plan are curved, with varied wall and roof planes evident on each facade. A lean-to (shed roof projecting from a wall) roof enclosure extends out from the east facade and a raised deck projects from the south facade. The two-story house has a partial basement and a partial subbasement. The second story is set back from the outer walls on all sides except the north facade and has curved northeast and southwest corners. An enclosed porch extends along the north side of the second story. Due to grade and setback of the second story, only one story is generally visible above grade on the front west facade, with just a small section of the second story's south end being visible.

2. Foundation:

A board-formed, perimeter grade beam foundation supports the building structure including at the east lean-to roof entrance. Form work consisted of 7" boards at straight runs (except at the north end of the east facade) with curved plywood at the curved northwest and southeast corners and along the north end of the east facade. Siding laps the sill plate and top edge of the foundation without a water table.

3. Cladding:

Lightly textured exterior plywood clads the building. Vertical channels are on 4" centers. Sheets with channels having five incised grooves creating four raised fluting having a rounded profile are 3/8" thick. These channels are 1/32" deep and 5/16" wide. Sheeting with 1/4" grooves that are 1/16" deep and without the incised grooves is 1/2" thick. The sheets at the east lean-to roof entrance are layered three deep. Butt joints occur at outer square building corners. The nominal 4' x 8' plywood sheets are oriented with the long edge vertical. A horizontal seam (butt joint) between plywood sheets wraps the building below the window headers. Plywood at the curved northwest and southeast (upper portion) corners is cut into and

attached as 3" wide strips to follow the curve. Replacement tongue and groove 3-1/8" boards occur at the lower portion of the southeast corner.

Brick veneer clads the lower 2' of the east lean-to roof entrance and is laid up in a running bond. Bricks have rounded arises and are 8-1/2" x 2-1/2" x 3-3/4" in size with 1/2" mortar joints. A cement wash extends along the top of the veneer at the transition to siding, except at the east facade windowsills.

Brick veneer clads the basement level, northeast portion of the house (from the east lean-to roof entrance north to the garage door) and is laid up in a running bond. Bricks have sharp arises, are painted, and are 2-1/8" x 8-1/8" x 4" in size with concave, 1/2" mortar joints. At the curved northeast wall corner, brick ends are cut at an angle to create a segmented curve with projecting and offset header joints.

Concrete block is used as cladding and structure for the projecting central portion of the building's north facade at the basement level. Blocks are laid up in a running bond, painted, and are 15-1/2" x 7-1/2" x 5-1/2" in size with 1/2" mortar joints. The outer northeast corner and upper two blocks of the northwest corner flanking the garage doorway utilize bullnose block having rounded exterior corners.

4. Structure:

Load bearing, wood stud framing comprises the wall framing for most of the building. Concrete block, described above in Walls, comprises the structure for the east portion of the building's north facade. Wood joists comprise the first and second floor and main roof framing. Rafters at the east entrance lean-to roof are 3-1/2" x 1-1/2" in section and carried on a ledger attached to the east facade and a 3-3/4" x 1-3/4" header at the outer east wall. Rafters at the north garage entrance are 2" x 4-1/4" in section.

A poured-in-place 7" thick concrete wall extends along the east end of the south facade. The added wall extends 2'-7" above grade and is offset just over 5" from the house wall. Based on the design, the wall is intended to provide a protective buffer from debris carried in flood waters to prevent the debris from hitting the side of the house.

5. Entrances:

The building has five entrances providing a range of access roles. Since the second-story porch is enclosed, the doorway to this porch is addressed as part of the interior description for the second floor.

The **front stoop** serves as the principal building entrance, leading to the first-floor entry hall. Placed near center on the front facade, the entrance is in the recessed portion of the facade. A flat roof with a low parapet projects out over the stoop. A pair of curved 2" diameter painted metal poles support the roof's southwest corner. Glass block sidelights flank the entrance. Concrete steps ascend to a concrete landing flanked by low brick planters with a flush panel solid core door opening to the interior. Textured exterior plywood clads the stoop ceiling. A painted metal replacement wall sconce is located at the south side of the doorway near the header. Replacement sheet metal coping wraps the roof parapet with Textured exterior plywood cladding the fascia. The north sidelight consists of three stacked, 11-1/2" square translucent, ribbed glass blocks with a painted wood brick molding. The south sidelight consists of a five-by-five grid of 5-3/4" square, stacked, translucent, ribbed glass blocks set behind a round frame opening with a curved painted wood brick molding. The south sidelight also provides daylighting to the entry hall coat closet and the dining room closet.

The **east entrance** provides access to an interior vestibule from the side yard, which connects to the subbasement recreation volume and to a mechanical space. A flush panel hollow core wood door set in a wood frame opens to the interior. A painted metal replacement wall sconce south of the doorway header provides exterior lighting. The supporting ledger and header carrying the rafters extend beyond the exterior walls of the entrance enclosure. A concrete walkway leads a 3' x 6' landing of 11-1/2" precast square concrete pavers.

The **north stoop** exits at the basement level from the shop space adjacent the garage volume and is the most direct route from the first-floor kitchen, via the basement, to the outdoor fireplace patio. Set within the north brick wall the flush panel hollow core wood door is set in a wood frame. A flat roof projects out over the stoop's concrete landing. Sheet metal flashing wraps the parapet with textured exterior plywood cladding the fascia and plywood at the soffit. A recessed round light with metal trim and a flat clear lens provides lighting.

The **garage entrance** provides access to the single-car basement garage. The replacement metal garage door rolls up to a horizontal position suspended on metal tracks above the garage volume. A steeply pitched lean-to roof covers projecting portion of the garage and overhangs slightly. A metal gutter extends along the eave and connects to a metal downspout.

The **south entrance** provides access from the dining room to the deck. A replacement sliding double door opens to the deck with an exterior sliding screen. The east door is inactive. Both doors consist of a single insulating

glass lights. A wood step within the dining room assists in the transition over the high threshold. The exterior deck connects to the house at the doorway threshold level. Painted metal 2-1/2" diameter metal posts support the L-shaped raised deck. Decking consists of Trex carried on incised pressure treated joists, replacing the original decking and framing. A replacement ledger bolted to the south facade of the house carries one end of the joists. The replacement railings consist of painted metal posts with cable railings.

6. Chimney:

A brick chimney services the first-floor fireplace. The internal chimney is located between the living room and garage. The exterior brick above the roofline is painted. The top of the chimney has an earthenware chimney pot with an arched sheet metal cap. The ashpit door is accessed from the subbasement bedroom space.

7. Windows:

The fenestration pattern for the building is irregular and driven primarily by internal configuration and ventilation needs rather than an exterior pattern or symmetry. Windows consist of original faceted, original glass block, added aluminum, and vinyl replacing wood sash windows. Most window openings have painted wood lug sills and projecting painted wood moldings with rounded corners over the window openings. Exceptions without the projecting moldings are glass block windows, sun porch windows, and those on the east facade of the east lean-to roof portion.

Faceted windows utilize individual glass lights as chords (line between two points on a curve) within the overall curved arc of a window opening. Each light is supported only at the top and bottom, with the outermost lights having jamb support. Vertical edges are beveled to create the angle for the next chord and have butt joints with a thin exterior glazing putty or similar bead. These windows are original and the most visually distinctive. They occur at the first story at the outer northwest (living room, 5 lights) and southeast (kitchen, 5 lights) corners and convey the overlapping influence of building form and internal function(s). Individual glass lights within these windows are 19" wide at the kitchen and 21" wide at the living room.

Subbasement windows occur at the recreation room, east lean-to roof portion, and bedroom, with an original relite in the laundry room. The recreation room windows are one-over-one-light vinyl sash; the room features two windows on the south facade and one on the east. The window openings have painted, mitered wood casings. Windows at the east lean-to roof portion consist of an aluminum horizontal slider on the

south facade and two aluminum fixed pane over small slider windows on the east facade. The north subbasement space window is a vinyl horizontal slider. A wood sash relite, with two horizontal lights in the east wall of the laundry room transmits daylighting from the windows in the east lean-to roof portion. The opening has a wood slip sill with the same projecting wood molding with rounded corners over the opening.

The only **basement** window is glass block and located at the curved northeast corner of the building. The 5-3/4" square, translucent, ribbed blocks are stacked with the ribbing in alternating directions. Blue, 1/2" ceramic tile bands occur above each row. The interior curved soffit, projecting stool, and jambs are finished with painted plywood. Narrow mitered, painted wood casings trim the curved opening.

First story windows occur at the living room, dining room, kitchen, and bathroom.

Living room windows consist of the curved northwest corner faceted window, a fixed two-light northeast corner window, and a southwest corner window. A painted round, 1-3/4" diameter metal corner post supports the headers above the northeast corner window with a narrow chrome muntin bridging the vertical joint between the glass lights. The two corner windows occupy most of the wall space at the north end of the living room, providing a high level of natural light. The southwest corner window consists of a vinyl fixed light on the west and a vinyl one-over-one-light sash on the south with a wood corner post separating the two windows.

Dining room windows consist of tall, fixed, replacement insulating glass lights with two on the south facade flanking the south doorway, and one on the south end of the west facade.

Kitchen windows consist of the curved southeast corner faceted window and a one-over-one-light vinyl sash window on the south facade above the sink.

Bathroom window consists of a vinyl horizontal slider in the east wall.

Second story windows occur at the bedroom, closet, and sun porch.

Bedroom window consists of two one-over-one-light vinyl sashes at the northeast corner, on the east and north walls.

Closet window consists of a vinyl horizontal slider on the east wall.

Sun porch consists of a large aluminum sash fixed on the east facade, and two aluminum sash horizontal sliders separated by a wood mullion on the north facade.

8. Roof:

The building's roofs occur at multiple levels, with different levels for the living room, dining room and kitchen, garage workshop area, bedroom, and the closet. All consist of a flat roof with a perimeter parapet. All have been reroofed. The parapet is curved at the northwest (first story), northeast (above the basement and second story), southwest (second story), and southeast (first story) corners. Sheet metal coping with pop rivet connections extends along the top of the parapets. Rolled composition roofing clads the main and the front and north flat stoop roofs. The roof over the dining room and kitchen slopes to the south with a scupper connecting to a metal leader head and exterior metal downspout. The living room roof drains to a metal leader head and exterior metal downspout near the northeast corner. The bedroom roof drains to a scupper on the east, that drains to the closet roof, which drains to the south into the dining room and kitchen roof.

Asphalt composition shingles clad the lean-to roof above the east entrance. A metal gutter extends along the eaves connecting to a metal downspout at the north end. Rafters are notched at the outer header and exposed.

The sun porch has two roofs. One is a small section of low-pitched roof with overhanging eaves, sheet metal drip flashing, and painted wood soffit. This extends over the southeast portion of the porch with a small parapet along the north side. The second is a lean-to roof with a metal gutter at the eave. Painted wood purlins supporting this roof extend beyond the sun porch wall planes. Rafters are exposed with a fascia board along the eave and sheathing for the soffit. Asphalt composition shingles cover the shed roof. Roofing at the flat roof is rolled composition roofing.

The lean-to roof is clad with asphalt composition shingles with a metal gutter along the eave. The gutter connects to a metal downspout that discharges at grade. Metal transition flashing spans the wall to roof joint.

C. Description of Interior

1. The interior layout consists of main living spaces on the first floor, including the entry hall, living and dining rooms, kitchen, and bathroom. The bedroom, sun porch, and walk-in closet are on the second floor. The basement consists of the garage and shop area with the recreation room, bedroom, a toilet room, and other secondary spaces in the subbasement. The basement is offset from rather than below the first floor, and instead resides below the second floor. The basement and second floor are offset vertically from but not a full story below or above the first floor, respectively.

2. Stairways:

The building has three stairways, providing access between the floors.

Stairway A connects the first and second floors. This stairway has the highest level of finishes and is a prominent visual feature within the entry hall and first floor. The open, straight run stairway ascends to a landing providing access to the second-floor bedroom. The attached bookcase serves to extend the wall along the north side of the stairway providing separation from the living room. A curved chrome railing extends along the south side of the stairway. Stair treads are Douglas fir or similar, with an 11" run, 1" thick, with a 1-5/8" nosing projection with a rounded southwest corner. Mahogany veneer plywood clads the risers. Tread ends are notched to receive the plywood cladding the stairway structure. The railing has 1" diameter round posts with flat 1-1/2" wide horizontal rails. The bookcase is clad with mahogany veneer with the graining oriented vertically, contrasting with the horizontal orientation of woodgrain in the plywood cladding the entry hall. The bookcase has a curved west end, functioning as a newel and is 8-1/2" wide x 34-3/4" long x 40-3/4" tall. A built-up linoleum or similar base with a 3/8" thickness wraps the base of the bookcase. The inner portion of the bookshelf is painted with the wood shelves facing the living room. A pair of mahogany veneer plywood doors on the south side of the stairway provide access to a linen storage cabinet. A hardwood screened return-air intake is located at the base of the south side of the stairway.

Stairway B connects the first floor and basement. The straight run stairway is boxed at the upper portion and open at the lower portion. The stairway descends from the entry hall to the south end of the basement garage space. Painted plywood clads the stairwell with a round metal 1-1/4" diameter pipe railing along the east wall. The sides of the stairs projecting beyond the side walls are clad with painted plywood. Treads are painted wood, with a 6-1/2" rise and 10-1/2" run with a 1-1/2" nosing

projection and vinyl non-skid overlay treads. Risers are plywood with a 3/32" thick linoleum with jute backing glued to the face of the wood risers.

Stairway C connects the basement and subbasement. The open straight run stairway has painted plywood walls where it passes through the north wall of the subbasement. A round metal 1-1/4" diameter pipe railing extends along the east wall. Concrete steps with a 6-1/2" rise and 11-1/2" run descend to the subbasement with a wall mounted fluorescent tube fixture above the doorway on the basement side.

3. Subbasement:

The subbasement is just over 3' lower than the basement and extends in an L-shaped plan below the first floor with curved northwest and southeast corners. The west wall of the subbasement is below grade with the rest of the floor above grade. Stairway C (letters assigned to stairways for ease of identification, refer to Stairways below under Description of Interior) connects the floor to the basement. The east entrance provides exterior access. Doors between spaces are flush panel, hollow-core wood, except the doorway to the bedroom, which has a single glass light and solid wood rails and stiles. Windows and doorways have painted, mitered wood casings. A concrete slab on grade floor extends throughout the floor. The subbasement includes the following rooms:

The **east vestibule** features a concrete floor, painted plywood ceiling, painted textured exterior plywood clad walls, and the south portion of the building's northeast painted brick wall. A single porcelain pull socket receptacle provides lighting.

The **mechanical space** has a concrete floor and exposed wood sheathing at the walls and ceiling. Added plywood shelving projects from the walls.

The **laundry room** has a concrete floor, painted 1/4" plywood walls and ceiling, and a wood relite in the east wall. A bowl ceiling fixture provides lighting.

The **toilet room** is below Stairway B and has a curved southwest corner wall. The space has a painted concrete floor, painted plywood walls and ceiling with painted wood corner trim at outer wall and ceiling edges. A wall-mounted sink and chrome trimmed wall-hung mirror are on the north wall, with a pedestal toilet in the west portion of the space. A flush-mounted ceiling light with a textured glass bowl provides lighting.

The **recreation room** occupies most of the subbasement and is in the east two-thirds of the south portion of this floor. The room has a painted concrete floor and painted plywood ceiling and walls. The ceiling has a

sanded finish. The southeast corner of the space and the north wall adjacent the doorway to Stairway C are curved. A soffit in the northeast portion of the space encloses plumbing from the bathroom above. A central boxed beam clad with stained plywood and cove moldings extends across the room. An added rattan wainscot over wall studs wraps the outer south and east walls. Two added flush mounted ceiling fixtures with textured glass bowls provide lighting. The doorway on the north side of the room to Stairway C has a stepped-back plate with a faceted pressed glass knob. A small closet is located off the northwest corner of the room with a sump pump.

The **office** is in the west third of the south portion of the subbasement. The original function of this space is not known. The room has corrugated metal clad walls (east), painted board formed walls (south and west), painted plywood ceiling, a painted concrete floor, and a stained plywood soffit enclosing upper floor ductwork. Porcelain keyless socket receptacles and ceiling mounted track lighting provide lighting. Added stained wood clad framing with two sets of bifold doors with metal frames and frosted glass enclose mechanical and storage space at the north end of the room.

The **bedroom** is in the north end of the subbasement, below the first floor living room. The original function of this space is not known. The room has painted board formed walls (west and north) and a painted concrete floor. The east wall consists of added built in storage spaces. A stained plywood clad beam extends the length of the space with painted grooved plywood ceiling west of the beam and an added drop ceiling east of the beam. Stained plywood added over the original grooved ceiling plywood clads the ceiling at the south alcove area converted for use as a bed. The concrete foundation steps in at the west and north walls. The northwest corner is curved. The base of the chimney is exposed at the east side of the room. Added track lighting along the ceiling provides lighting, with added clear glass shade ceiling and wall fixtures at the bed area.

4. Basement:

The basement is offset from both the basement and first floor and above grade. The floor has a rectangular plan with a curved northeast corner and extends below the second floor. Stairway B connects to the first floor and Stairway C to the subbasement. The garage entrance and north stoop provide access to the driveway and the fireplace patio to the north. A concrete slab on grade floor extends throughout the floor. The basement includes the following rooms:

The **garage** volume has painted plywood walls and ceiling with a wood trim band along the wall/ceiling joint. A porcelain keyless socket receptacle provides lighting. The east side of the brick chimney, the

cantilevered back of the living room display case, and a cantilevered plumbing chase project into the garage space along the west wall. The garage volume has multiple built in storage and work areas. A projecting wall-mounted cabinet adjacent Stairway B has the outer northwest corner supported by a 2" diameter painted metal post. The cabinet has sliding painted plywood doors on metal tracks with recessed round metal pulls. A second wall-mounted cabinet is above Stairway C with wood side-hinged doors, butt hinges, and a cabinet turn latch to secure the doors. Both cabinets adjacent the stairway feature rounded corners. A pass-through workstation accessible from both the garage and shop areas is built into the wall between these two spaces. The open pass-through is trimmed with painted mitered casings with a chrome trimmed counter. The counter surface is the same added floor tiles used in the first floor entry hall. Below the counter are a pull-out plywood shelf, multiple wood tool drawers with tapered, chrome bar drawer pulls that are flanked by a single cabinet with a single round chrome knob. Hinges at the cabinet door are chrome, face mounted with an ornamental surface hinge having two sets of thin horizontal grooves. The outer corners of the projecting drawer and cabinet portion are rounded. A Plexiglass display case is mounted to the wall above the passthrough. A storage closet on the west side of the garage has a single recessed panel wood door with a sliding door at the transom. The door has a plain, square corner escutcheon with a round painted metal knob.

The **shop** area is east of the garage and has painted plywood walls and ceiling with a wood trim band along the wall/ceiling joint. The passthrough at the work bench is trimmed with mitered wood casings. A small storage cabinet with a plywood door is in the southwest corner of the space. A porcelain keyless socket receptacle provides lighting.

5. First floor:

The first floor has an L-shaped plan with the west portion at grade level and the south and east portions one-story above grade. The outer northwest and southeast corners are curved. Stairway A connects to the first and second floors and Stairway B to the basement. Refer to mechanical equipment for a description of heat registers. The first floor includes the following rooms:

The **entry hall** has an L-shaped layout and serves a key circulation role and receiving space for visitors. The volume is shared by Stairway A and an L-shaped hallway linking all the rooms on the first floor and connecting to stairways A and B. A mahogany trimmed beam and the mahogany veneer plywood bookcase forming part of Stairway A mark the transition to the living room. A coat closet with a curved east wall is located to the right of the front door upon entering. Added vinyl 12" square floor tiles with a

scored grid overlay the original hardwood flooring and extend into the closet. Added rubber base (4" tall) at the walls ends a 1/2" below the casings and replaces the original 4-1/2" base comprised of three layers of linoleum with jute backing for a finished 3/8" thick base.

Mahogany veneer plywood clads the walls. The sheets are free from defects and repairs with a continuous veneer like a rotary cut (rotating the log against the knife edge). The triple-layer plywood has 1/16" thick layers and is stained in alternating bands of light and dark with a horizontal round backed groove every 16". The grooves do not cut through the full thickness of the outer veneer layer. The plywood is finished with a satin or semi-gloss clear coat. The north wall consists of in-kind replacement attributed to correcting water damage. Mahogany casings at doorways are thin 5/8" wide x 3/8" thick, with larger 1-1/4" wide mitered casings at the front door.

The ceiling is stepped above the hallway and flat above Stairway A. Pressed fiber acoustical panels with an imprinted floral design and linear edging at each panel finishes all horizontal surfaces. Stained mahogany boards trim out each of the four vertical steps with a curved board above the curved closet wall. A mahogany triangular molding wraps the west and south walls. A narrow mahogany trim band wraps the top of the walls at the upper ceiling portion above Stairway A. This upper ceiling portion contains the rectangular metal ceiling mounted light fixture illuminating the space. Flush panel hollow core mahogany veneer doors provide access to the closet, Stairway B, and the bathroom. The closet retains the original base, with painted plywood walls and ceiling. Glass blocks on the exterior west wall provide lighting for the closet.

The **living room** has a rectangular layout with a short leg at the south end connecting to the entry hall. The northwest corner is curved. The room's north wall extends beyond the wall plane of the rest of the house enabling a northeast corner window with views to the north and east. The fireplace and display case both reside on the east wall. Stained oak 2-1/2" wide flooring in 16" lengths extends throughout the space. An oak return air grate is in the floor at the southwest corner of the room. The room's plywood walls are textured (spray on, trowel finished) and painted with these finishes extending behind the stained 1-1/2" tall mahogany baseboard. A paint shadow remains along the top of the walls from a former narrow cornice molding and at the outer southwest corner from a former 1/2" corner molding. Window openings are trimmed with 1" mitered, mahogany casings, with mahogany stools (2-1/4" to 3-1/4"), aprons (1-1/4"), soffits, and jambs. All wall and window trim elements follow the curvature of the northwest corner. Added metal drapery rods extend above the windows supporting added shear and opaque drapery.

The stained Douglas fir or similar plywood ceiling steps (three total) up towards a center raised panel, with two additional steps at the south end of the room above the leg. The steps follow the curvature of the northwest corner. Each step is 1-1/4" tall (1" Douglas fir or similar spacer and one layer of 1/4" plywood). The sheets are free from defects and repairs with a prominent variegated wavy figure like half-round sliced veneer (cut slightly across the annual rings). Veneer is random matched on sheets. Sheets are arranged with the grain pattern following the length of each step and the raised central panel. The 1/4" plywood has a high gloss clear-coat finish. Sheets are face nailed with finish nails and filled. Round backed grooves in cut into the plywood divide the sheets into a 16" grid with diagonals radiating out from the northwest corner of the center raised panel. Sheet ends are beveled to replicate the grooves. The center raised panel has a single groove boarder with rounded outer corners. The living room face of the beam between the living room and entry hall matches the living room walls with a narrow mahogany trim piece transitioning to the mahogany soffit. Extending the living room wall finish across the side of this beam provides a visual separation between the stained plywood of the living room ceiling and the entry hall walls.

The display case is 3'-9" wide x 3'-2" tall and 1'-6" deep with the back of the case projecting into the basement garage volume. A 1" wide stained and mitered mahogany casing wraps the opening. Metal tracks remain along the top and bottom edge of the case front from former sliding doors. The plywood cabinet sides are painted, with rounded back corners.

The fireplace has a 6' x 4' Vitrolite glass mantel. A 2-1/2" mitered, stained mahogany casing with rounded edges wraps the edges of the mantel. An added pellet stove and metal surround set within the mantel. The hearth extends the width of the mantel with a 19-1/2" projection into the living room. The hearth consists of 5-1/2" square black ceramic tiles, with 1/4" black grout lines. A 2" wide, mitered wood trim oak extends around the hearth.

The **dining room** has a rectangular layout and serves as the access point for the south deck. A closet with a curved outer corner projects into the space at the northwest corner. A slight inward step of the wall at the northeast corner of the room accommodates the recessed refrigerator location in the adjacent kitchen. Oak flooring matching the size of the living room, but with an added darker stained finish, extends throughout the space and into the closet. Walls are textured and painted plywood matching the living room, except for the west wall that is not textured. Doorways have 1-5/8" painted mitered wood casings, with 1-1/4" painted casings at the windows. An added painted 3-1/2" tall wood base with a cyma reversa profile extends around the room. Back scoring of the baseboard allowed the curved installation at the closet corner. Painted,

fiberboard or similar 16" square tiles clad the ceiling. A cove light (LED, multicolored) set behind the prominent cornice along the south and west walls provides indirect lighting. An added chandelier suspended by a chain from the ceiling and plugged into a wall outlet is located above the dining table. The board along the ceiling above the cornice consists of oak or mahogany and was originally stained and later partially painted. A flush panel mahogany veneer, hollow core door with replacement hardware provides access to the closet. Added metal curtain rods extend above the windows supporting added drapery.

The **bathroom** has a rectangular plan. The curved walled bump out for the vanity projects into the kitchen to the south. Vinyl 12" square floor tiles with a scored grid overlay the original flooring. A 6-1/2" tall original black tile wall base consists of 4-1/4" square tiles with an upper 2" tall tile band with 2" square tiles at the outer ends on each wall. Walls consist of enamel-coated hardboard (Colotyle) with a 1/32" thick enamel finish with a warm orange-tan tint. The sheets are 3/16" thick and installed horizontally with 3/8" chrome bands connecting the sheet edges with wider 5/8" chrome bands at outer corners. Shallow 1/16" deep horizontal grooves in the panels on 16" centers extend around the room. An 1-1/2" band provides a visual wainscot cap bridging the seam between panels and consists of a composite material (vinyl or similar) with two shallow 1/8" wide grooves painted silver-white. A fan set behind a 10-1/2" x 8-1/2" chrome metal vent in the east wall exhausts to the exterior. A stained mahogany 5/8" cove band wraps along the top of the walls. The ceiling consists of 12" square fiberboard or similar tiles painted white with a painted black border. The window has a 3-1/4" mahogany stool with 3/8" chrome trim at the outer corner of the painted plywood jambs and soffit. The doorway has 1-1/4" mitered mahogany casings with rounded edges and a flush panel hollow core mahogany veneer door with the interior face painted to match the bathroom wall color. An added metal flush mounted light fixture with both down and directional lighting is in the central portion of the ceiling.

The vanity is set within a curved wall alcove clad with Colotyle, with painted plywood or similar at the soffit. A heat register is in the wall below the counter at the seating area. A recessed 9-1/2" square metal light with a frosted lens provides overhead lighting. An oval mirror in a chrome frame is mounted to the wall above the vanity. The vanity consists of a base of two sets of drawers flanking a seating space with a full width counter. The outer corners of the painted (matching the walls) plywood base are rounded. The face frame drawers have chrome bar pulls with painted blue horizontal grooves. Quarter round painted wood trim covers the base/wall joints below the counter. The counter is stained mahogany with a 1/4" thick clear Plexiglass top.

The porcelain sink has a beveled front with exposed chrome plumbing below. The sink's straight back connects to the wall with tapered hexagonal, chrome straight legs supporting the front edge with chrome hexagonal towel bars at both sides extending between the legs and the wall. A rectangular mirror with a decorative three groove cross hatch in the upper left corner and set in a chrome frame hangs above the sink. Lumiline or similar wall brackets flank the mirror. A tall, shallow, built-in cabinet is east of the sink with a decorative lever and stepped-back plate with 3/8" chrome strips wrapping the doorway. The porcelain floor mounted toilet has a tank with beveled corners and raised outer front corners on the toilet pedestal. A recessed chrome toilet paper roll holder is north of the toilet above bathtub.

The built-in recessed tub is set between the east wall and the built-in shower. A border of black square tile wraps along the top edge of the bathtub. The tub knobs and spout are located on the east wall with water lines hidden behind the wall. A built-in chrome soap and wash cloth holder is along the north wall above the tub. Raised outer profiles on the tub's outer wall match those on the toilet. The built-in shower consists of a tiled stall with white, composite paneling on the upper walls and ceiling, a textured translucent glass panel on the east side, and glass door set in a metal frame on the south side. The outer corner consists of a stained mahogany post. The walls above the glass panel and door are Colotyle.

The **kitchen** has a rectangular plan and is characterized by curved walls, cabinets, and soffits. The curved southeast window adjacent the breakfast table is the focal point upon entering the room and provides views of the yards and Clarks Creek and the rock weir. The curved north wall with the built-in ironing board and pantry serves as a prominent visual feature within the room.

Replacement vinyl laminate comprises the flooring. An added 4" rubber base is applied over a plywood backer with a replacement ceramic tile cap and is shorter than the original 6-1/2" base. Walls consist of the same enameled hardboard (Colotyle) as the bathroom with horizontal grooves painted dark blue. The wainscot band is 1-1/8" wide with a center raised blue vinyl or similar 3/8" band flanked by chrome. Chrome, 3/8" bands occur at all sheet joints, notably edges, inner and outer corners. The ceiling consists of approximately 12" square fiberboard or similar panels. Soffits with curved outer corners extend above the upper cabinets at the outer walls. The doorway to the entry hall does not have a door and does not appear to have had one. Narrow, 1-1/16" mitered mahogany casings trim the doorway. The ironing board and cabinet on the north wall are cased with 5/8" mahogany trim mitered with rounded edges. The corner window has a curved 5" deep stool with a 2-1/8" apron, both are

mahogany. The window above the sink has mahogany jambs (4-1/8"), soffit, stool (5"), apron (1-1/8"), and mitered casings.

Counters and appliances are arranged in an L-shape along the south and west walls creating the kitchen triangle with the sink on the south wall below the window and the stove and refrigerator along the west wall. The stove and refrigerator have both been replaced. Cabinets above the counters and flanking the refrigerator utilize doors, with drawers located below the counters along with two pull-out bread boards. The northeast corner contains a separate set of cabinets, curved under-counter shelves, and a small counter. The double-basin, enameled iron cabinet sink (22" x 40-1/2") has a tall (8") apron and back with curved front corners. The painted plywood cabinet below the sink has curved outer corners matching the sink. Under-counter cabinets are painted plywood and set on a recessed base with chrome bar pulls with three grooves each painted dark blue at the drawers. Drawers all have painted wood fronts but drawer sides and backs are both painted wood and metal. Cabinets above the counters are painted plywood. There are both face frame and butt hinges used on cabinet doors. The cabinets flanking the window above the sink have narrow mahogany strips attached to their inner face in three horizontal rows. Counters throughout the kitchen are added cultured stone with a white ceramic tile backsplash. A through-wall vent is on the south wall. Opening the vent door turns on the fan. Lighting is provided by a pendant light with a white and gold painted metal conical reflector and a recessed fixture above the sink.

6. Second floor:

The second floor is located above the basement garage with the walk-in closet projecting south over the shop portion of the basement. The floor has a T-shaped plan due to the closet projection. Stairway A connects to the first floor. The second floor includes the following rooms:

The **bedroom** occupies most of the second floor with a corner window at the northeast corner. Hardwood flooring matching the living room extends throughout the space. Walls have texture applied over the plywood and are painted, like the living room. Added unpainted corrugated metal sheets clad the west wall. A mahogany base matching the living room extends around the perimeter walls. The ceiling has painted, fiberboard or similar ceiling tiles matching those in the kitchen. The corner windows have mahogany stools, aprons, jambs, soffits, and 1" mitered casings.

The **walk-in closet** is east of the bedroom and consists of a central walkway flanked by closets. Hardwood flooring matching the living room extends throughout the space. Plywood walls have the same finish as the bedroom, but the mahogany base is missing. Top hung flush panel hollow

core mahogany veneer doors open to the two closets. The window opening at the east end of the walkway has 1"-mitered casings and a stool, both mahogany.

The enclosed **sun porch** is at the north end of the bedroom. A flush panel hollow core mahogany veneer door with a 10-3/4" diameter port hole window opens from the bedroom to the porch. The doorway has 1"-wide mitered mahogany casings. Flooring consists of added wall to wall carpeting. Textured exterior plywood clads the south and west walls, and the north wall below the windows. Painted plywood clads the upper portion of the east wall. A wood beam spans east to west across the space at the flat to sloped ceiling transition. The ceiling consists of painted plywood. The parapet for the second-floor roof extends along this beam. An added wall sconce above the doorway provides lighting. A square raised section is in the southwest corner of the porch and clad with textured exterior plywood.

7. Mechanical equipment:

The building utilizes a ducted forced air heating system with the furnace in the subbasement directly south of the chimney. Ducting extends out through the subbasement with soffits enclosing supply and return air ducting. Baseboard metal registers, measuring 13" wide by 11-1/2" tall occur in each of the first floor rooms. Ceiling diffusers are in the subbasement. The return-air intake is located at the base of Stairway A on the first floor.

Attic ventilation consists of metal through wall vents on the north and south facades of the building.

The electric power connect for the building is on the south facade.

Plumbing for the first-floor bathroom and kitchen is enclosed in soffits and walls, except for a waste pipe from the kitchen extending down the south wall of the subbasement. The building has its own septic system and well.

D. Site

The designed landscape, attributed to Bert Smyser, conveys the influence of Clarks Creek on the use patterns by the Smyser family, and the role of site topography in shaping both landscape and building spatial organization.

1. Spatial organization:

The placement of the house within the generally triangular tax parcel immersed the building within the landscape and influenced the arrangement of interior floor levels relative to the surrounding topography, shaping functional and visual connections between the building and landscape. The following are the main spaces within the site:

The **west yard** is the publicly visible landscape between 66th Avenue E and the house providing the public setting for the house. This yard features a front lawn, foundation plantings along the building, circulation features and pathway lighting, and trees and shrubs north and south of the house to frame the front facade and screen the private south yard from the road.

The **south yard** is shaped by its former role as part of Clarks Creeks' broader arc west across 66th Avenue E. This is a private lawn space set below the roadway grade level with screening from trees in the west yard, south edge, and a large light standard. It is visually connected to the subbasement recreation room and first floor kitchen via windows and the south deck with functional connection to the greenhouse.

The **east yard** is a private space shaped by circulation including two sets of stairs, grade transitions, a pump house, lawn, and a retaining wall and associated vegetation. This yard is functionally related to the east entrance and north stoop as well as Clarks Creek.

The **fireplace patio** is shaped by design and function. This private space consists of a retaining wall, stairs, Common Horse-chestnut tree, patio area and a built-in fireplace.

The **north yard** provides an expansive functional area north of the house and west of the fireplace patio and includes a Black Walnut tree, driveway, and tool shed. Changes in use have added chicken coops and associated outbuildings, north driveway extension, and a garden. An added chain link fence with metal posts encloses this area and separates the garden from the spaces associated with the chicken coops.

2. Circulation:

Exterior circulation features include driveways, paths, stairways, as well as lighting and markers supporting their navigation.

Driveways

Driveways provide vehicular access to the site from 66th Avenue E, onsite parking, and connection to the basement garage. Granite curbs, described

below under the principal driveway, are used as edging for the driveways and part of 66th Avenue E are estimated by the current property owner to extend over 160 linear feet.

The **principal driveway** varies in width but is generally 21' wide paved with asphalt and extends over 70' from 66th Ave E to the garage. Retaining walls extend along the north (wall 5) and east (wall 6) sides to retain the driveway fill with a light post at the northeast corner. Granite curbs mark the south edge of the driveway and are attributed as salvage materials originating ca. 1890s at an unknown location and relocated to their current placement by Bert Smyser as part of the landscape development. The curbs are each 6" to 8" thick, approximately 2' wide (extending down into grade), and over 8' long.

The **added driveway** extends to the north and previously functioned as parking for a large recreational vehicle (RV). This small, asphalt-paved driveway has a granite curb along the east side with a concrete curb with chamfered edges along the west side.

Paths

Paths provide pedestrian circulation routes within the site. These consist of concrete walkways, a ramp, and pavers.

Walkways extend out in a curvilinear manner from the front stoop with one walkway at the north stoop. The walkways consist of concrete with a finer aggregate topcoat and were poured in long runs with few cold joints. The main 3'-5" wide walkway from the front stoop runs east, branching near the north end of the house. The west branch continues northwest to stairway 1, the east branch wraps the northwest corner of the house, tapering in width to 2' as it descends to stairway 2. Another walkway branches off the main walkway near the front stoop. The walkway curves around the base of the trees off the southwest corner of the house, tapering to 2' in width down to the south yard and extending along the south side of the greenhouse. A low retaining wall (wall 3) flanks the north side of the walkway. The walkway at the north stoop extends from stairway 6 and curves around the northeast corner of the house to the east yard.

Pavers are round pre-cast concrete, nominally 18" diameter and spaced to provide a walking surface through the lawn. They are in the east yard. One series of seven pavers extend from the east entrance north to the walkway extending out from stairway 6. Another series is mostly overgrown with lawn, but consists of 2 to 3 pavers and extends northeast from the same walkway to stairway 4. Concrete pavers set in concrete extend from the fireplace patio area up to the chicken run area. Another

set of 4 pavers extends south from the east entrance along the edge of the house foundation to the south yard.

The concrete **ramp** is located east of the east entrance and is attributed to use as a wheelbarrow ramp. The ramp descends the steep slope from the landing at the top of stairway 3 down to the south yard. The upper end of the ramp is 11" wide and expands out to a 36" wide round end. The curved landing at stairway 3 extends beyond the south concrete stringer to provide the connection for the ramp.

Stairways

Stairways provide an important circulation feature for navigating the site's steep topography. All are poured-in-place concrete with a pronounced back angle to the risers.

Stairway 1 is northwest of the house and connects via three steps the west branch of the main walkway with the driveway. A metal 1-3/4" diameter pipe railing extends along the east side. The stairway has rounded 10"-wide cheek walls with an overall 5'-3" width. Steps have a 5-1/2" rise and 13" run.

Stairway 2 is north of the house and connects via five steps the east branch of the main walkway with the driveway. A brick planter extends along the south side of these stairs. The steps are each generally 2' square with exposed aggregate with a 5" rise. A granite curb forms the riser for the starting step.

Stairway 3 is east of the east entrance, at the south end of retaining wall 1, and connects via six steps the upper and lower portions of the east yard. Stairs have a 6-1/2" rise and 14" run with a 16" run at the bottom tread before the lower landing. Concrete stringers with rounded lower ends flank the stairs with a 1-3/8" diameter metal pipe railing along the north side of the stairway and a small concrete landing at the top of the stairs. The stairway widens from 24" wide stairs at the top to 32" wide at the bottom. A low portion of the retaining wall extends along the north side.

Stairway 4 is south of the pump house and connects via six steps to the upper and lower portions of the east yard. Concrete sidewalls from retaining wall 1 flank the stairway. A curved metal 1-3/8" diameter pipe railing extends along the south side of the stairway. Stairs have a 13" run and 5-1/2" rise.

Stairway 5 extends from the driveway to the fireplace patio via twelve steps. A short section of rounded cheek wall matching the cheek walls at stairway 1 is at the top northeast corner. The stairway curves slightly with

the west side following the arc of retaining wall 2. A large square starting step allows users to approach the stairway from either the north or east. Stairs (12) are winders, narrower at the inner edge, with a nominal 14" run and 5" rise. A concrete plaque is in the east wall of the stairway; the top edge of the plaque has two scallop depressions. The cursive writing is no longer completely legible with just the following readable "Geo. D [?] C [?]."

Stairway 6 is off the northeast corner of the house and connects via two sets of two stairs the driveway and north stoop with the east yard. Steps from the driveway are rectangular with rounded corners and a 13" run and 7" rise. Steps from the north stoop form part of the stoop landing and are curved with a varying rise and run.

Lighting

Lighting, except for the south yard light, mainly serves to illuminate walkways and stairways. The south yard light, based on its type and location, would have illuminated a portion of the south yard and deck area.

A **twin reflector** post light has a round 2" diameter post with a replacement light having two round 4-5/8" diameter metal reflectors at the top directing light downward and a solar panel on the top. This light occurs at the top of stairway 5 and rises from the concrete post functioning as part of the railing system along retaining wall 6.

Single reflector post lights have a round 1-1/2" diameter plastic post with one round 6" diameter plastic reflector at the top directing light downward. These occur at the top of stairway 2.

Triple reflector post lights have a round 1-3/4" diameter post with a replacement light having three round 6" diameter plastic reflectors at the top directing light downward. These occur along the east side of the main walkway on plastic posts, adjacent to stairway 1. The fixture adjacent to stairway 1 has a unique 12-point concrete star base that is 1'-5" in diameter and rises from a round 2'-4" round concrete base. The metal post is 2" in diameter. A duplex receptacle is also located at the base of the fixture.

The **south yard** light is a single tall light metal fixture located off the south side of the house. The tall, 1-3/4" diameter metal post is set in a round 11" diameter concrete foundation. A metal diagonal brace extends to the west and a concrete foundation. The light has a metal hinged base allowing the fixture to be lowered to replace the bulb. The conduit runs up and out the top of the post. A round metal bracket through bolted to the post supports the light fixture which has a round glass shade.

3. Water features:

The landscape's water features provide an important aesthetic component that is tied to the natural hydrologic system. Water faucets for watering occur near the south yard light and recessed into the retaining wall on the east side of the driveway.

Clarks Creek is the main water feature and is attributed to shaping much of the topography that the design utilized to create spaces within the landscape. The stream extends along the east side of the property. The salmon-bearing stream brings associated plant and animal life contributions to the visual and auditory setting, as well as exhibiting seasonal changes, including water level changes and loss of foliage, that influence the experience of the site. Vegetation patterns in historic aerial imagery taken in 1941, 1957, and 1968 suggest prior to development of 66th Avenue E, the stream arced at least 90' west of today's roadway. Remnants of this channel remain north of the driveway leading to 4902 66th Avenue E and in the topography of the south yard. The stream provides the setting for the fireplace patio area and is prominently featured in the view from the curved kitchen window adjacent the breakfast table.

The **rock weir** is just over 70' upstream from the house and slightly east of the property boundary. The auditory qualities created by the ripple effect of the rock weir contribute to the experience of the site. According to the current owner, the rock weir was constructed by Bert Smyser. The rock weir consists of large rocks built out from either side of the stream bank.

4. Topography:

Topography, as the shape of the ground plane, is an influential feature shaping the house design, including the vertical placement of interior floor levels, and spatial organization of the landscape. Topography is attributed as a natural feature created through the action of Clarks Creek, with elements created through excavation as part of site construction, fill from construction of 66th Avenue E. Fill placement from road construction created an elevated, raised berm along the west edge of the property. The creek follows a winding just over 3-mile route from its source at Maplewood Springs north to the Puyallup River. The creek receives water during the wet season from multiple tributaries.⁸³ Retaining walls were

⁸³ State of Washington, Department of Ecology, "Clarks Creek." URL: <https://ecology.wa.gov/Water-Shorelines/Water-quality/Water-improvement/Total-Maximum-Daily-Load-process/Directory-of-improvement-projects/Clarks-Creek>, accessed November 3, 2022.

used in the landscape design to modify the topography as part of creating outdoor spaces, such as the driveway and fireplace patio.

Site topography consists of the steeply sloped creek channel that is just over 20' wide at the creek bed and at an elevation around 15'. The east bank across the creek from the property rises steeply to 25' in elevation. The west bank along the south and east yards rises steeply to 20' in elevation along the creek edge. The extent of side grading and fill as part of the house construction is not known.

The **west yard** is around 28' in elevation, rising gradually to the west by 3' to the roadway level. This yard is about 8' above the south yard elevation, enhancing the screening role of vegetation on its east side for the south yard.

The **south yard** has a relatively level central portion at 20' in elevation, with the north, south, and west sides rising sharply to enclose the space and place it around 11' below the roadway and 3' below the house's subbasement. Low tiers of stacked rock and a single 28" diameter concrete paver mark the west edge.

The **east yard** is two tiered and shaped by both the creek bank and house construction. Retaining wall 1 defines the tier transition and creates the level shelves along the top of the creek bank and west of the retaining wall.

The **fireplace patio** is around 18' in elevation, just above the creek level, and nearly 13' below the roadway level, providing some privacy relative to traffic along the road. Development of the patio space is attributed to Smyser, including excavation and construction of retaining wall 2 to maintain and define the west edge the space.

The **north yard** has an overall consistent downward slope from west to east that increases in steepness as the site narrows to the north. The area drops from around 31' in elevation at the road to 23' in elevation above the fireplace patio.

5. Vegetation:

Vegetation has changed since the 1940s based on review of historic aerial imagery. The details of original and historic period site plantings, particularly around the house and in the yards, are not known. Vegetation identified by Spencer Howard is based on the best available data from field observations in October 2022 of leaf, structure, and bark characteristics. Lawn comprises most of the west, south, and east yards. The site contains a variety of trees, which are addressed by planting area

except for the Black walnut and Common Horse-chestnut, which are addressed individually. Historic associations are noted where they could be identified through archival records and historic aerials.

The following content presents vegetation arranged by planting beds. These lists are not exhaustive but sought to identify the key plants influencing the visual character of each bed. The planting beds, unless otherwise noted, appear based on materials and location to be original. How the vegetation within these beds has changed over time is not known.

The tree at the east side of the fireplace patio is a **Common Horse-chestnut** (*Aesculus hippocastanum*).

The tree at the south end of the north yard with birdhouse on east side is a **Black walnut** (*Juglans regia*).

Raised brick planters flanking the **front stoop** are 3'-4" x 5'-6" on the north and 3'-10" x 5'-6" on the south. The brick planters are a single wythe thick with rounded corners where they connect with the steps. The north planter includes an Alpine daphne (*Daphne alpina*). The south planter includes Canna lily (*Canna indica*) and Nasturtium (*Tropaeolum*), a small unknown conifer shrub, and Western swordfern (*Polystichum munitum*).

Area 1 along the west side of house wrapping the northwest corner to the north facade, from south to north, includes Old fashioned weigela (*Weigela florida*), an unidentified shrub, White Cedar (*Thuja occidentalis*), Common boxwood (*Buxus sempervirens*) in front of the window, David viburnum (*Viburnum davidii*) along the north portion with a Western swordfern (*Polystichum munitum*) at the east end. The north portion of the planting area transitions to a curvilinear single-wythe brick walled planter flanking stairway 2. The planter is 2' wide at the east end and 11'-6" long.

Area 2 northwest of the house across the east branch of the main walkway, from east to west, a Holly (*Ilex aquifolium*) along the north side of stairway 2, Common boxwood (*Buxus sempervirens*), several roses along the west branch of the main walkway and some succulents at the west end adjacent stairway 1.

Area 3 west of stairway 1 includes Red-hot-pokers (*Kniphofia uvaria*) and Yucca (*Yucca filamentosa*) as understory plantings below the Japanese maple (*Acer palmatum*). This planting area contains a replacement flagpole anchored to two 8" square chamfered edged concrete posts.

Area 4 is the west edge of the south yard from the south property boundary north to the front stoop. From south to north, the area includes at the south end with a Common Birch (*Betula pendula*), Common

boxwood (*Buxus sempervirens*) and English ivy (*Hedera helix*) understory planting, north of the boxwood is the Western redcedar (*Thuja plicata*) and an American Rhododendron (*Rhododendron maximum*) and then a Rocky mountain or Creeping juniper (*Juniperus scopulorum* or *horizontalis*) and a green bark Japanese maple (*Acer palmatum*), two Western red cedar (*Thuja plicata*), with an American Rhododendron (*Rhododendron maximum*) and Western swordfern (*Polystichum munitum*) adjacent the house.

Area 5 around the greenhouse and south deck includes red grape (*Vitis*) growing at the deck support, an Edible fig (*Ficus carica*), and south of the grape is a Common Hazel (*Corylus avellana*).

Area 6 along the south property line includes a low trained tree, Common Birch (*Betula pendula*) along the creek, with a Sitka spruce (*Picea sitchensis*) in the southeast corner behind the bench with a Common boxwood (*Buxus sempervirens*) and English ivy (*Hedera helix*) understory planting and two Eastern Red Cedar (*Juniperus virginiana*).

Area 7 along retaining wall 1 north to the stairway 5 includes a rose at the south end, Common boxwood (*Buxus sempervirens*), Dwarf Alberta spruce (*Picea glauca*) and Red-hot-poker (*Kniphofia uvaria*) along the top, planted behind the retaining wall. Adjacent the pump house, on the south side, False Solomon's Seal (*Maianthemum racemosum*) and north of the pump house Red-hot-poker (*Kniphofia uvaria*).

Area 8 along the east side of the house, directly north of the shed roof addition, from south to north, includes Iris (*Iris germanica*), a Sage (*Salvia officinalis*), and a Common boxwood (*Buxus sempervirens*). The concrete planter at this location is 8' x 2'-8".

Area 9 along the base of the east shed roof addition, south of the doorway, includes Apple mint (*Mentha suaveolens*).

Area 10 along the retaining wall west of the fireplace patio include a Smooth hydrangea (*Hydrangea arborescens*) and Red-hot-poker (*Kniphofia uvaria*) at north end.

Area 11 planting bed with a concrete outer wall along the east edge of retaining wall 6 includes several roses and English ivy (*Hedera helix*), Japanese pieris (*Pieris japonica*) or similar, and either Japanese-lantern (*Physalis alkekengi*) or Cape gooseberry (*Physalis peruviana*).

North yard plantings along the west side of the chicken run are not part of a planting bed, but include Holly (*Ilex aquifolium*), along with American Rhododendron (*Rhododendron maximum*) and White Cedar (*Thuja occidentalis*). The tree off the southeast corner of the shed 3 is a Magnolia

(*Magnolia*). Plantings along the north side of wall 5 include American Rhododendron (*Rhododendron maximum*) with Western swordfern (*Polystichum munitum*) understory plantings and English ivy (*Hedera helix*) along the chicken wire and chain link fence south of the rhododendron.

6. Structures and outbuildings:

The site includes multiple structures and outbuildings added at different time periods.

The current owner indicated a former timber bridge crossed Clarks Creek to access an enclosed pool on the property east of the creek. Some remnant posts and a submerged beam remain in the creek; however, conclusive evidence of the bridge existence and location were not identified in archival and historic aerial records. Access to the property to the east was not possible and is no longer part of the property.

Retaining Walls

Retaining walls provide an important tool for holding back sloped areas to create level circulation and activity spaces.

Wall 1 is along the east side of the site, between stairways 3 and 5. The wall is battered and angled back towards the top. The wall is 3" wide at the top and comprised of rock with a concrete parging and cap. Round plaques of varying diameters (generally 18") are set in the concrete parging along the wall's east face. Most of the plaques date from 1989 except for one at the north end dating to 1949. The wall varies in height but is generally 2'-8". Refer to the Table of Plaques in Supplemental Material for inscriptions.

Wall 2 extends from stairway 5 north to the concrete pads leading up to the chicken run and extends behind the fireplace. A chain link fence with round metal posts, functioning as part of the chicken run enclosure, extends along the top edge of the retaining wall. The wall is vertical, comprised of rock with a concrete parging and cap. The wall is generally over 2' in height south of the fireplace, and then tapers down in height north of the fireplace. Round and irregular shaped plaques of similar size to those in wall 1 are set in the concrete parging along the wall's east face. Plaques along this length of wall tend to be older than wall 1.

Wall 3 off the southwest corner of the house and consists of a low rock retaining wall with concrete parging. The wall follows the curve of the walkway descending to the south yard.

Wall 4 creates terraces within the chicken run area and consists of stacked rubble concrete topped with square concrete pavers. Based on the construction this wall is attributed as a later addition.

Wall 5 is rubble concrete and rock with a 10" wide cast-in-place concrete curb along the top capped with rocks. An 8" square concrete post with chamfered corners marks the east end of the wall, with at least two additional concrete posts along the westward length of the wall. This wall retains fill at the driveway.

Wall 6 has an 11" wide concrete curb along the top edge with 8" square concrete posts at the outer corners. An 18" tall 1-1/4" diameter pipe railing extends along the two areas flanking the pump house to provide fall protection. A round drain projects east through the north end of the wall. A metal light post rises from the center of the north concrete post. This wall retains fill at the driveway.

Fireplace Patio

The brick fireplace serves as the focal point for the roughly 500 square foot concrete patio along Clarks Creek. The elevation of the patio is just a few feet above the creek level. The fireplace faces west and consists of a large central hearth with a brick mantel and corbeled brick ledge along the upper portion of the mantel. Four clay chimney pots project above the chimney. Added stone clads the chimney. Angled brick wings with concrete caps extend out from the hearth. The north wing functioned for food preparation and included a sink with cabinets below and a storage area. The south wing contained a small oven with an ash catch below and a round metal coal holder for baking with a low grille area. Added stone clads part of the grill area. The original use of the concrete niches flanking the fireplace are not known. The fireplace brick matches the brick used on the brick planters around the house.

Greenhouse

Abutting the south side of the house, the greenhouse consists of metal, gable roofed structure with a stepped profile. The lower 2' tall single wythe brick portion of the exterior walls utilizes the same brick as at the east entrance with a cement wash at the top. A cement parging clads the inner face. The metal structure consists of welded T bar. Solid exterior panels consist of painted fiberboard. The lower panel on the door is sheet metal. The interior features a brick floor with multiple cast concrete panels with Art Nouveau inspired designs loose along the south and west walls of the structure.

Pump house

The pump house is a poured in place concrete structure with a concrete roof. The structure has a 4'-6" x 9'-4" plane with the same rounded outer northeast corner as the house. A corbel projects on the east side. Formwork for the structure consisted of plywood at the curved corner with boards at the straight walls. Based on field observations, the sections of retaining wall 1 were built after the pump house. The roof is at the same level as the driveway.

Shed No. 1

This is a sheet metal clad tool shed with a 9'-6" x 8'-4" rectangular plan. The building stands on a concrete foundation. A pair of flush panel metal doors on the south side provide access. A low-pitch front gable roof with flush eaves and gables and clad with metal shelters the interior. Corrugation on the metal consists of two closely spaced narrow corrugations alternating with wide panels.

Shed No. 2

This shed, identified by the current owner as a former outhouse, is a wood frame, gable roofed structure. The current owner identified the 8-light wood sashes in the shed as having been removed from the house as part of the vinyl window installation. The shed has a 5' x 4' rectangular plan and is clad with drop siding. A wood batten door provides access to the interior. This structure is attributed based on construction as a later addition.

Well House

This building is a wood frame structure with a rectangular plan. The structure has a shed roof and is clad with textured exterior plywood. A flush panel door in the east side provides access. This structure is attributed as a later addition based on its construction.

Chicken Coop 1

The chicken coop is a wood frame, flat roofed structure. The current owner identified the two horizontal light wood sashes as having been removed from the house as part of the vinyl window installation. Based on design, these may have functioned as part of the southwest corner window at the living room. The coop has an 8' square plan. Vertical boards clad the front and sides with metal sheeting at the back. A flat roof projects out over the flush panel front door. This structure is attributed based on construction as a later addition.

Chicken Coop 2

This chicken coop is a wood frame, gable roofed structure clad with plywood. This coop and associated chicken wire enclosed run have a 9' x 6' plan. The eaves and gable ends have slight overhangs. This structure is attributed based on construction as a later addition.

PART III: SOURCES OF INFORMATION

A. Works consulted

Primary sources:

Bureau of Land Management-General Land Office (BLM-GLO). *General Land Office Records*. "Patent CDI Doc 1644422." Digital images. https://glorerecords.blm.gov/details/cdi/default.aspx?doc_id=1644422&sid=i2d4ryio.h0n. Accessed November 2, 2022. John Hote. Pierce County, Washington.

---. *General Land Office Records*. "Patent CDI Doc 1644445." Digital images. https://glorerecords.blm.gov/details/cdi/default.aspx?doc_id=1644445&sid=04kgt5iv.ea. Accessed November 2, 2022. Milton Fisher. Pierce County, Washington.

Edrington, Charles R. "1941 Housing Exposition Here." *The Tacoma News Tribune*. December 29, 1940: 6.

---. "Entertainment at Housing Show Tops." *The Tacoma News Tribune*. February 20, 1941: 6.

---. "Housing Show Will End Run Tonight." *The Tacoma News Tribune*. February 23, 1941: 1, 11-A.

"Executive Order 9066: Resulting in the Relocation of Japanese (1942)." *Our Documents*. <https://www.ourdocuments.gov/doc.php?flash=false&doc=74>. Accessed November 9, 2022.

Glenn, Stacia. "Record-setting year for rain and heat." *The News Tribune*. January 2, 2016: 3A.

Kroll Map Co. "Atlas of Pierce County, Wash., T. 20 N. R 4 E." Seattle: Kroll Map Co., 1915. <https://content.libraries.wsu.edu/digital/collection/maps/id/887/rec/27>. Accessed October 12, 2022.

Maypenny, George W., Commissioner. "Puyallup Reservation, Department of the Interior, Office of Indian Affairs, January 19, 1857." *Executive Orders Relating to Indian Reservations: From May 14, 1855, to July 1, 1912*. Government Printing Office: Washington, D.C., 1912.

National Archives. "Dawes Act (1887)." *National Archives*. <https://www.archives.gov/milestone-documents/dawes-act>. Accessed November 2, 2022.

Pierce County Assessor. Parcel 20110500100. Electronic document.
<https://atip.piercecountywa.gov/app/propertyDetail/2011050010/building>. Accessed November 15, 2022.

Pierce County Auditor. *Deed records of Pierce County, 1859—present*. Tacoma, Pierce County, Washington.

Anderson, Andrew and Eva. May 17, 1929. Deed Record Book: No. 514: 311.

Fisher, Milton, and Puyallup Indian Commission & August Svenson. September 15, 1920. Deed Record Book: No. 438: 603

Harris, Jamison R., and Jeremy R. Shuler and Maureen J. Shuler. September 3, 2015. Instrument No. 201509210442 (digitized).

Sheldon, Ronald K. and Sandra K. Sheldon and Lucas A. Smith and Heidi L. Palmer-Smith. July 20, 1999. Instrument No. 9907260383 (digitized).

Smith, Lucas A., and Heidi L. Palmer-Smith and Jamison Robert Harris and Jeremy Richard Shuler. October 31, 2008. Instrument No. 200811060198 (digitized).

Smyser, Allen B., Executor of the Estate of Bert Smyser, deceased, and David Smyser. June 30, 1987. Deed Record Book No. 0437, 0682 (digitized).

Smyser, David A., and Ronald K. Sheldon and Sandra K. Sheldon. September 1, 1989. Deed Record Book: No. 0564, 0768 (digitized).

Svenson, Laura A., and Helen F. Smyser and Bert A. Smyser. December 29, 1944. Deed Record Book No. 890: 823 (digitized).

R. L. Polk & Co. *Polk's Tacoma City Directory, 1920*. Tacoma, WA: R. L. Polk & Co., 1920.

---. *Polk's Tacoma City Directory, 1921*. Tacoma, WA: R. L. Polk & Co., 1921.

---. *Polk's Tacoma City Directory, 1947*. Seattle: R. L. Polk & Co., 1947.

The Seattle Post-Intelligencer.

"\$35,000 Exhibit to be Installed." March 12, 1939: 40.

The Seattle (Daily/Sunday) Times.

"Colotyle: Porcelain-like Walls for Modern Homes." May 14, 1939: 37.

"Incorporations." July 12, 1937: 19.

"Society News." August 3, 1913: 26, column 2.

"Stone-Fisher Company's Artistic Window Display Wins in Tacoma Rose Society Competition." June 27, 1913: 4.

"Venetian Blind at New Location." May 30, 1937: 9.

The Tacoma (Daily/Sunday) Ledger.

"An Indian's Will." September 7, 1887: 5.

"Land sales not very large." May 3, 1895: 3.

"Named Chairman for Window Displays Here." December 6, 1918: 9.

"Puyallup's Festival Next Week." July 17, 1936: 14.

"Real Estate Transfers." July 31, 1903: 11.

"T. R. & P. Co. Had Novel Float Parade Saturday." June 10, 1919: 7.

"Tacoma Display Man Winner of Prizes, Trophies." October 4, 1925: 6-A.

The (Tacoma) News Tribune.

"\$30,000 So. Tacoma Way Fire Draws Thousands." August 12, 1940: 1.

"Bert Smyser, the 'display man,' dies." February 18, 1987: 14.

"Boardwalk Show Opens." March 2, 1941: 11.

"Dedicate Exposition Hall and Housing Show." February 18, 1941:

"Display Shows Plywood Uses." January 5, 1938: 11.

"First Big Time Housing Show in Tacoma Gets off to Auspicious Start Saturday Night for a Nine Day Run. Exhibitors Flooded with Visitors Throughout Saturday Night, Sunday." February 18, 1941: 16.

"Graybar Co. Chief to Visit." August 18, 1955: A-11.

"Home Show Saturday." February 9, 1941: 7.

"Housing Exposition Is Off to Fine Start." February 16, 1941: 1.

"House of Tomorrow." March 6, 1941: 6.

"Modern Supply Celebrates 10th Anniversary." January 15, 1939: 12-A.

"Modern Supply Co. to Move." January 5, 1941: 11-A.

"New Exposition Building." August 22, 1940: 6.

"Permits for Building Take \$37,000 Jump." August 21, 1940: 13.

"Photo-Mural to be Gift." February 3, 1946: 1.

"Pleads Guilt in Tax Trial." June 23, 1954: 6.

"Plenty of Room for Spectators." June 21, 1941: 10.

"Puget Sound Incorporations." July 12, 1937: 3.

"Realtors Told of Housing Exposition." February 9, 1941: 7.

"Tiny Plant Soars into Alder Tree." February 23, 1964: 22.

"Vital Statistics: Notice of intent to wed." December 31, 1980: B-19.

The Tacoma Times.

"Bert Smyser Behind Deal." January 4, 1940.

United States Government. *Medicine Creek Treaty*. Washington Territory, 1854. <https://digitreaties.org/treaties/treaty/12013261/>. Accessed November 3, 2022.

United States, Puyallup Indian Commission. "Map of the Puyallup Indian Reservation Washington." Government Printing Office: Washington, 1892.
<https://content.libraries.wsu.edu/digital/collection/maps/id/219/>. Accessed December 5, 2022.

U.S. Census Bureau. *Twelfth Census of the United States: Reservation Precinct, Pierce County, Washington*. 1900. Enumeration District 150. Sheet 14B.

---. *Twelfth Census of the United States: Tacoma, Pierce County, Washington*. 1910. Enumeration District 258. Sheet 12A.

---. *Sixteenth Census of the United States: Riverside E. Precinct, Pierce County, Washington*. 1940. Enumeration District 27-84. Sheet 1B.

U.S. Geological Survey. Aerials obtained through <https://earthexplorer.usgs.gov/> for the years of 1941, 1957, and 1968.

Vital Statistics Agency, Victoria, Canada. "British Columbia Marriage Registrations, 1859-1932; 1937-1938." *FamilySearch.org*. <https://familysearch.org/ark:/61903/3:1:S3HY-6M8G-61?cc=1307718&wc=S6K9-82S%3A9701>. Accessed November 1, 2022.

Washington State Archives. "Death Certificate: Velma A. Mathison, March 29, 1983." Department of Health, Death Certificates. Washington

State Digital Archives. <http://digitalarchives.wa.gov>. Accessed November 10, 2022.

---. "Marriage License: Ronald K. Sheldon and Sandra Johnson, January 17, 1981." Department of Health, Marriage Certificates. Washington State Digital Archives. <http://digitalarchives.wa.gov>. Accessed November 10, 2022.

Secondary sources:

Artifacts Consulting, Inc. "Prairie Line Rail Corridor: Historic and Cultural Assessment Report." December 2016. Prepared for the City of Tacoma. https://cms.cityoftacoma.org/PLT_Webpage/PLT-Assessment.pdf. Accessed November 8, 2022.

Carpenter, Cecilia S. *Tears of Internment: The Indian History of Fox Island and the Puget Sound Indian War*. Tahoma Research Service: Tacoma, 1996.

Chesley, Frank. "Puyallup – Thumbnail History." *Historylink.org the Online Encyclopedia of Washington State History*. January 22, 2008. <https://www.historylink.org/file/8447>. Accessed November 8, 2022.

City of Long Beach. "4.10, Streamline Moderne: 1934-1945." *Long Beach Historic District Design Guidelines*. https://www.longbeach.gov/globalassets/lbds/media-library/documents/planning/historic-preservation/districts/guidelines/chapter-4-10_streamline-moderne. Accessed December 6, 2022.

Denfeld, Duane Colt, PhD. "Seattle inventor and manufacturer Frank Hobbs is awarded army contract for prefabricated Pacific huts on September 6, 1942." *Historylink.org the Online Encyclopedia of Washington State History*. June 3, 2010. <https://www.historylink.org/File/9430>. Accessed October 12, 2022.

Emerson, Stephen. "W. P. Fuller and Company Warehouse." National Register of Historic Places nomination. 1995. Available via <https://npgallery.nps.gov/GetAsset/5b424126-b131-46fb-9941-60046d38fdc0>. Accessed October 12, 2022.

Fiset, Louis. "Camp Harmony (Puyallup Assembly Center), 1942." *Historylink.org the Online Encyclopedia of Washington State History*. October 7, 2008. <https://www.historylink.org/file/8748>. Accessed November 8, 2022.

- Hilbert, Vi, Jay Miller, and Zalmay Zahir. *Puget Sound Geography: Original Manuscript from T. T. Waterman*. Lushootseed Press: Federal Way, Washington, 2001.
- Historical Research Associates, Inc. "Structure Move Feasibility Determination, Clarks Creek Property Acquisition and House Relocation." In *Feasibility Study for Clarks Creek Property Acquisition and House Relocation*. August 2018. Prepared by Tetra Tech. Prepared for Pierce County Planning & Public Works.
- Lane, Barbara. Anthropological Report on the Identity, Treaty Status and Fisheries of the Puyallup Tribe of Indians. Prepared for the U.S. Department of the Interior and the Puyallup Indian Tribe. On file, ESA, Seattle. 1975.
- Lange, Greg. "Smallpox epidemic ravages Native Americans on the northwest coast of North America in the 1770s." *HistoryLink.org Online Encyclopedia of Washington State History*. January 23, 2003. <https://www.historylink.org/File/5100>. Accessed September 14, 2022.
- Puyallup Tribe of Indians. "Puyallup Tribal History." *Puyallup Tribe of Indians*. <http://www.puyallup-tribe.com/ourtribe/>. Accessed November 3, 2022.
- Reddick, Suann M., and Cary C. Collins. "Medicine Creek Remediated: Isaac Stevens and the Puyallup, Nisqually, and Muckleshoot Land Settlement at Fox Island, August 4, 1856." *The Pacific Northwest Quarterly*. Vol 104, No. 2. Spring 2013. <https://www.jstor.org/stable/24631631>. Accessed November 3, 2022.
- Schaefer, Kurt Kim, "The Promise and the Price of Contact: Puyallup Indian Acculturation, Federal Indian Policy and the City of Tacoma, 1832-1909," PhD diss., (University of Washington, 2016), 7.
- Smith, Harlan I. *Archaeology of the Gulf and Puget Sound*. The Jesup North Pacific Expedition, Memoir of the American Museum of Natural History, New York, Volume II, Part VI. E.J. Brill, Ltd., Leiden, and G. E. Stechert, New York. 1907.
- Smith, Marian W. *The Puyallup-Nisqually*. Columbia University Contributions to Anthropology No. 32. Columbia University Press: New York, 1940.

Spier, Leslie. *Tribal Distribution in Washington*. American Anthropological Association General Series in Anthropology No. 3. George Banta: Menasha, Wisconsin, 1936.

SRI Foundation. "Washington State's Historic State Roads: Historic Context for Island, Snohomish, King, Pierce, and King Counties." January 2014.
<https://dahp.wa.gov/sites/default/files/Roads%20Historic%20Context.pdf>. Accessed November 10, 2022.

Suttles, Wayne, and Barbara Lane. "Southern Coast Salish." In *Northwest Coast*, edited by Wayne Suttles, pp. 485-502. Handbook of North American Indians, Vol. 7, William C. Sturtevant, general editor. Smithsonian Institution: Washington, D.C., 1990.

Tacoma-Pierce County Buildings Index. "1406 54th Ave E, Fife." *Tacoma Public Library*.
<https://cdm17061.contentdm.oclc.org/digital/collection/p17061coll1/id/42209/rec/1> . Accessed December 5, 2022.

---. "2102 South Tacoma Way, Tacoma," *Tacoma Public Library*.
<https://cdm17061.contentdm.oclc.org/digital/collection/p17061coll1/id/20209/rec/4>. Accessed December 6, 2022.

Taylor, Herbert C., Jr. Anthropological Investigation of the Medicine Creek Tribes. In *Coast Salish and Western Washington Indians II*, edited by David Horr, pp. 401-473, American Indian Ethnohistory: Indians of the Northwest. Originally presented before the Indian Claims Commission, Docket No. 234, Defense Exhibit No. 129, 1953. Garland: New York, 1974.

Thrush, Coll. *Native Seattle: Histories from the Crossing-Over Place*. Seattle and London: University of Washington Press, 2017. 2nd edition. E-book.

Wilma, David. "Tacoma Public Utilities." *Historylink.org the Online Encyclopedia of Washington State History*. December 16, 2002.
<https://www.historylink.org/File/5025>. Accessed October 12, 2022.

B. Architectural drawings

No architectural drawings or site plans were identified.

C. Early views

Historic U.S. Geological Survey aerials obtained through <https://earthexplorer.usgs.gov/> for the years of 1941, 1957, and 1968 provided some insight into historic site characteristics including circulation, vegetation, and the former route of Clarks Creek; however, due to resolution limitations the level of detail was limited. The 1957 aerial had the highest resolution.

D. Interviews

Project team member discussions with the current property owner Jeremy Shuler and his mother Maureen Shuler during site visits October 3-7, 2022.

E. Likely sources not yet investigated

Pending

F. Supplemental material

1. Index of photographs

The following photographs were taken by Spencer Howard on September 7, October 3, and October 4, 2022. All images shot in RAW format and exported as 300 dpi TIFF images.

DAHP Log No TKTK-0001 House, front west facade, looking east.

DAHP Log No TKTK-0002 House, front stoop, looking east.

DAHP Log No TKTK-0003 House, northwest corner, looking southeast.

DAHP Log No TKTK-0004 House, north facade, looking south.

DAHP Log No TKTK-0005 House, northeast corner, looking southwest.

DAHP Log No TKTK-0006 House, east facade, looking west.

DAHP Log No TKTK-0007 House, southeast corner, looking northwest.

DAHP Log No TKTK-0008 House, south facade, looking north.

DAHP Log No TKTK-0009 Site, south yard, looking northeast.

DAHP Log No TKTK-0010 Site, rock weir, looking northeast.

DAHP Log No TKTK-0011 Site, light fixture, looking north.

DAHP Log No TKTK-0012 Greenhouse, southeast corner, looking northwest.

DAHP Log No TKTK-0013 Greenhouse, southwest corner, looking northeast.

DAHP Log No TKTK-0014 Greenhouse, east facade, looking west.

DAHP Log No TKTK-0015 Greenhouse, interior, looking south.

DAHP Log No TKTK-0016 Site, east yard, looking northwest.

DAHP Log No TKTK-0017 Site, east yard, looking southwest.

DAHP Log No TKTK-0018 Site, east yard, looking northwest.

DAHP Log No TKTK-0019 Site, west yard, looking southeast.

DAHP Log No TKTK-0020 Site, stairway 1, looking southwest.

DAHP Log No TKTK-0021 Site, light fixture, looking east.

DAHP Log No TKTK-0022 Site, driveway, looking east.

DAHP Log No TKTK-0023 Site, stairway 5, looking southwest.

DAHP Log No TKTK-0024 Site, fireplace patio, looking northwest.

DAHP Log No TKTK-0025 Site, fireplace, looking west.

DAHP Log No TKTK-0026 Site, retaining wall 2, looking west.

DAHP Log No TKTK-0027 Site, fireplace patio, looking south.

DAHP Log No TKTK-0028 Site, north yard, looking west.

DAHP Log No TKTK-0029 Site, north yard garden, looking north.

DAHP Log No TKTK-0030 Site, chicken coop 1, looking southwest.

DAHP Log No TKTK-0031 Site, chicken coop 2, looking east.

DAHP Log No TKTK-0032 Site, shed 1, looking northwest.

DAHP Log No TKTK-0033 Site, north yard, looking south.

DAHP Log No TKTK-0034 Site, shed 2, looking southeast.

DAHP Log No TKTK-0035 Site, looking north along Clarks Creek.

DAHP Log No TKTK-0036 Site, north yard, looking east.

DAHP Log No TKTK-0037 Site, well house, looking southwest.

DAHP Log No TKTK-0038 Site, pathway looking south.

DAHP Log No TKTK-0039 Entry hall, looking east.

DAHP Log No TKTK-0040 Entry hall, Stairway A, looking northeast.

DAHP Log No TKTK-0041 Entry hall, looking west.

DAHP Log No TKTK-0042 Entry hall, looking south.

DAHP Log No TKTK-0043 Living room, looking north.

DAHP Log No TKTK-0044 Living room, looking southwest.

DAHP Log No TKTK-0045 Living room, looking south.

DAHP Log No TKTK-0046 Living room, faceted window, looking northwest.

DAHP Log No TKTK-0047 Living room ceiling, looking southwest.

DAHP Log No TKTK-0048 Living room ceiling, looking north.

DAHP Log No TKTK-0049 Living room, display case, looking northeast.

DAHP Log No TKTK-0050 Living room, fireplace, looking east.

DAHP Log No TKTK-0051 Bathroom, looking east.

DAHP Log No TKTK-0052 Bathroom, vanity, looking southwest.

DAHP Log No TKTK-0053 Bathroom, shower, looking northwest.

DAHP Log No TKTK-0054 Bathroom, bathtub, and toilet, looking northeast.

DAHP Log No TKTK-0055 Kitchen, looking southeast.

DAHP Log No TKTK-0056 Kitchen, looking northeast.

DAHP Log No TKTK-0057 Kitchen, looking southwest.

DAHP Log No TKTK-0058 Kitchen, looking south.

DAHP Log No TKTK-0059 Kitchen, vent, looking south.

DAHP Log No TKTK-0060 Kitchen, looking west.

DAHP Log No TKTK-0061 Kitchen, looking west.

DAHP Log No TKTK-0062 Dining room, looking west.

DAHP Log No TKTK-0063 Dining room, looking northeast.

DAHP Log No TKTK-0064 Dining room, looking south.

DAHP Log No TKTK-0065 Deck, looking northwest.

DAHP Log No TKTK-0066 Deck, south yard, looking south.

DAHP Log No TKTK-0067 Second floor bedroom, looking north.

DAHP Log No TKTK-0068 Sun porch, looking east.

DAHP Log No TKTK-0069 Second floor bedroom, looking west.

DAHP Log No TKTK-0070 Closet, looking east.

DAHP Log No TKTK-0071 Basement, garage looking north.

DAHP Log No TKTK-0072 Basement, shop, looking east.

DAHP Log No TKTK-0073 Basement, shop, looking south.

DAHP Log No TKTK-0074 Basement, garage work area, looking southeast.

DAHP Log No TKTK-0075 Basement, garage, looking south.

DAHP Log No TKTK-0076 Basement, Stairway B, looking southeast.

DAHP Log No TKTK-0077 Basement, Stairway C, looking south.

DAHP Log No TKTK-0078 Subbasement, recreation room, looking southeast.

DAHP Log No TKTK-0079 Subbasement, recreation room, looking west.

DAHP Log No TKTK-0080 Subbasement, bathroom, looking northwest.

DAHP Log No TKTK-0081 Subbasement, east vestibule, looking south.

DAHP Log No TKTK-0082 Subbasement, office, looking south.

DAHP Log No TKTK-0083 Subbasement, office, looking north.

DAHP Log No TKTK-0084 Subbasement, bedroom, looking north.

DAHP Log No TKTK-0085 Subbasement, bedroom, looking south.

2. Table of Plaques

The following table starts at the south end of the retaining wall 1 and works north.

Cross check on site and get one on floor of patio

[Internal note Images referenced under
 Photographs/Site_220907/Reference images]

No.	Inscription	Image
1	"Our children Annette, Diane, [?], 1989"	Ext_167
2	"In Memory our Parents Ken [and] Irene Sheldon 1989 and Ed [and] Irene Olmsted 1989"	Ext_168
3	"Ron and Sandy Sheldon Making This a Dream House Again (Sept [?]) 1989"	Ext_169
4	"Our Loving Dog Muffin 1989"	Ext_170
5	"The Gang Sandy B. Larry Harold BH, Freddie, 8-17-49"	Ext_171
6	"[?]+ Helen [?]"	Ext_172
7	"[?] Forever [?]"	Ext_173
8	"Have you [?] -48"	Ext_181
9	"J [?] -46 [?] Kennedy [?]"	Ext_182
10	"Geo. D[?] C[?] [?]"	Ext_183
11	"Bert + Helen Smyser Love + Happiness 6/5/40" Wedding date for the Smysers.	Ext_185
12	"Mother Svenson 9-1-42"	Ext_186
13	"Dad G. H. Smyser Aug 1-48"	Ext_187
14	"Regards from Spring (?) Valley Alma and Rey Ayres 8/31/1948"	Ext_188
15	"The Lovejoys Leila and Scott 8-15-48"	Ext_205
16	"9/4/48 Fair Friends All Kays Helen Harold Cranston Seattle"	Ext_190
17	"Greetings from Gladys Tool[?] Camas [?] Wash [?]-19-48"	Ext_191
18	"Happy Memories 8-12-1977 The Normans Jane (Tool) and Jack Loudoun County Virginia"	Ext_192

19	“[?]”	Ext 193
----	-------	---------

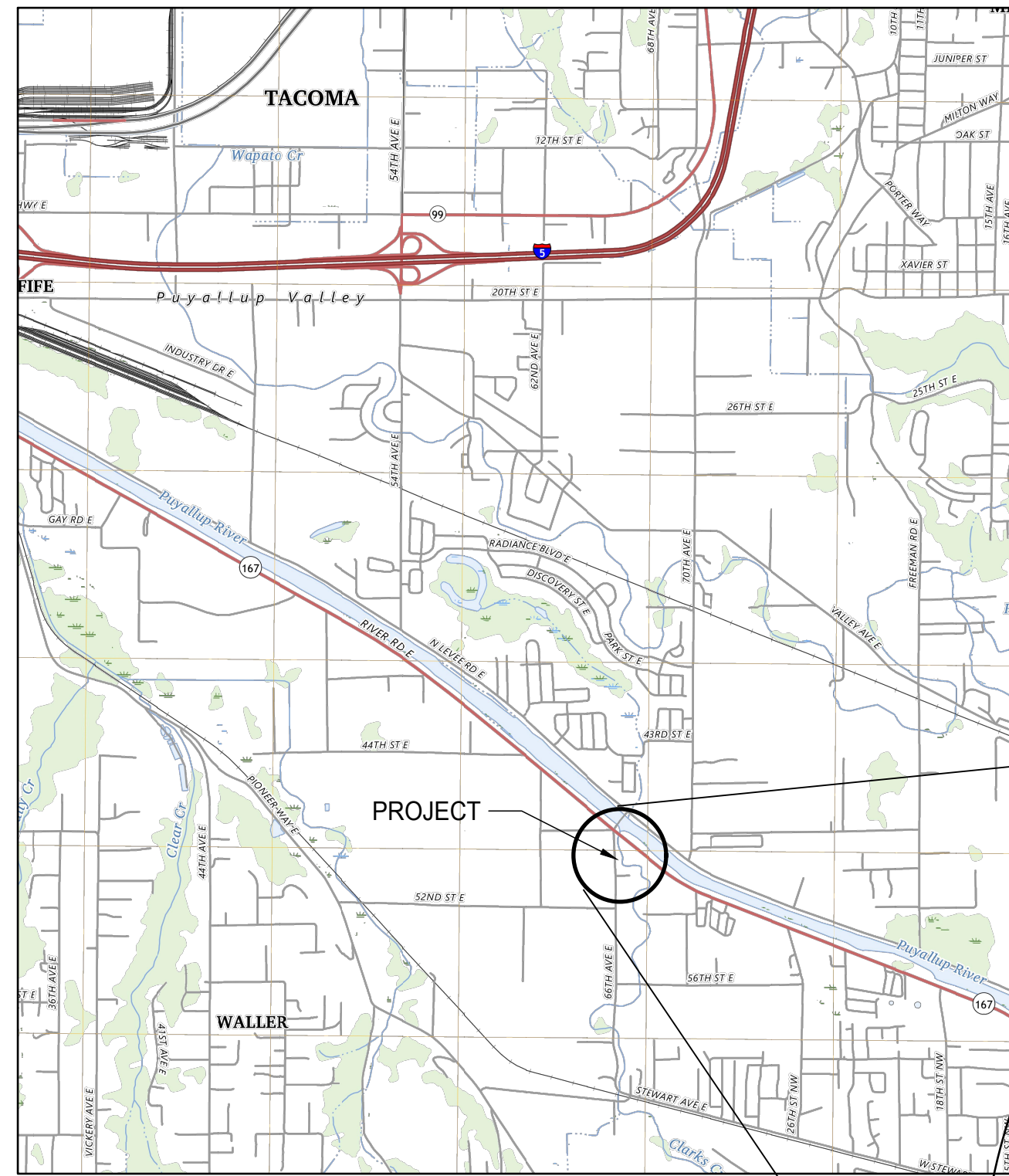

PROJECT LOCATION

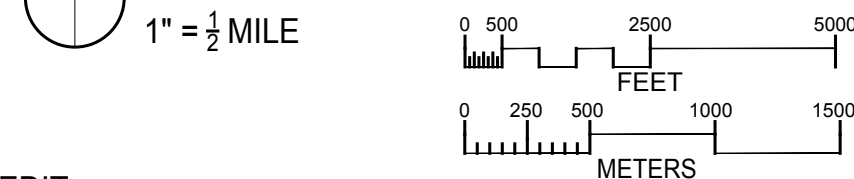

MAP CREDIT:
US DEPARTMENT OF INTERIOR, UNITED STATES GEOLOGICAL SURVEY, 7.5 MINUTE TOPO 1, WASHINGTON, 2022

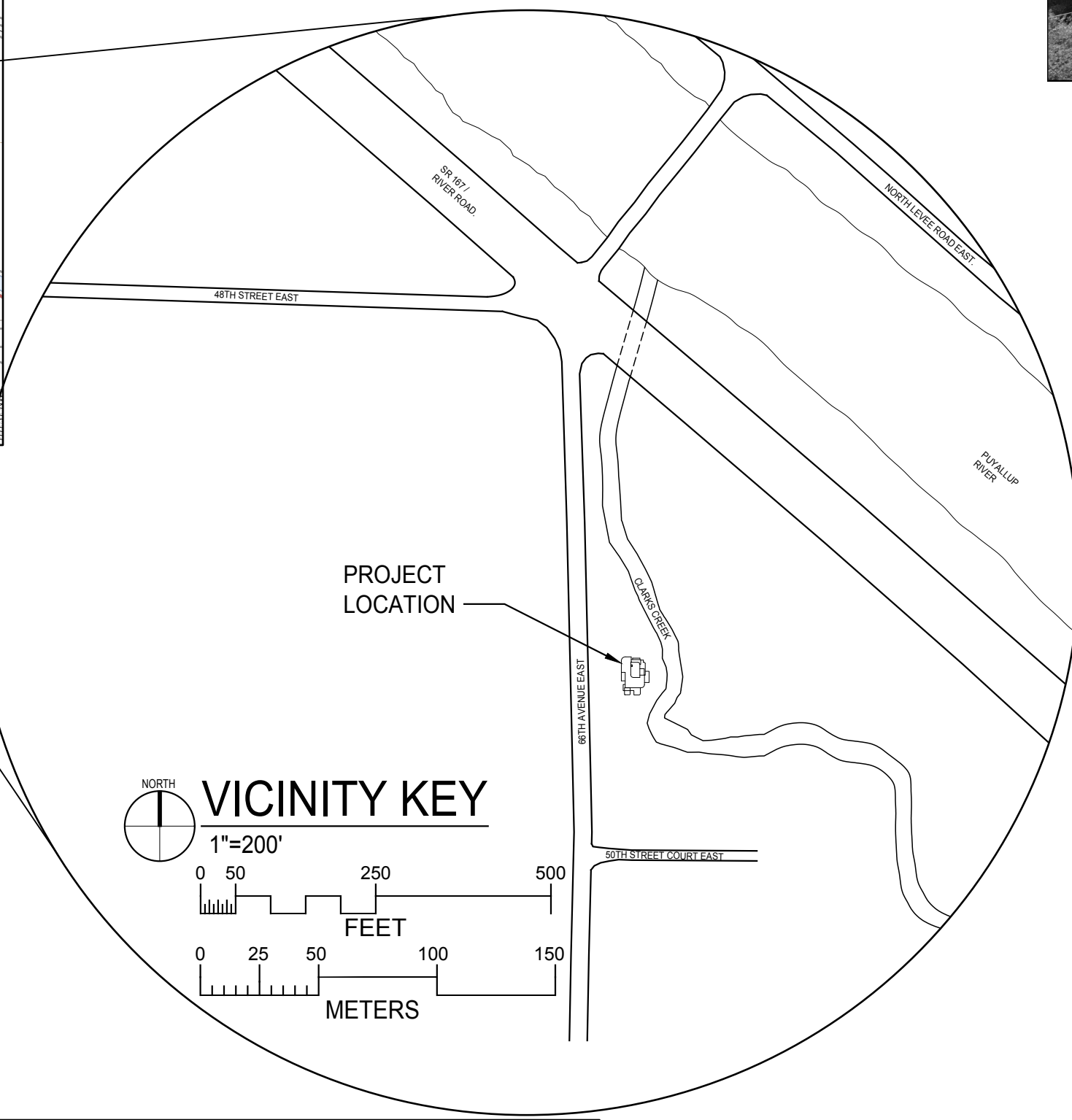

PROJECT LOCATION

VICINITY KEY

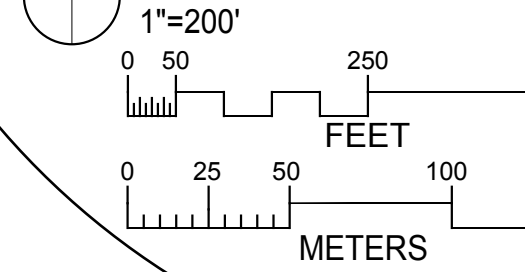
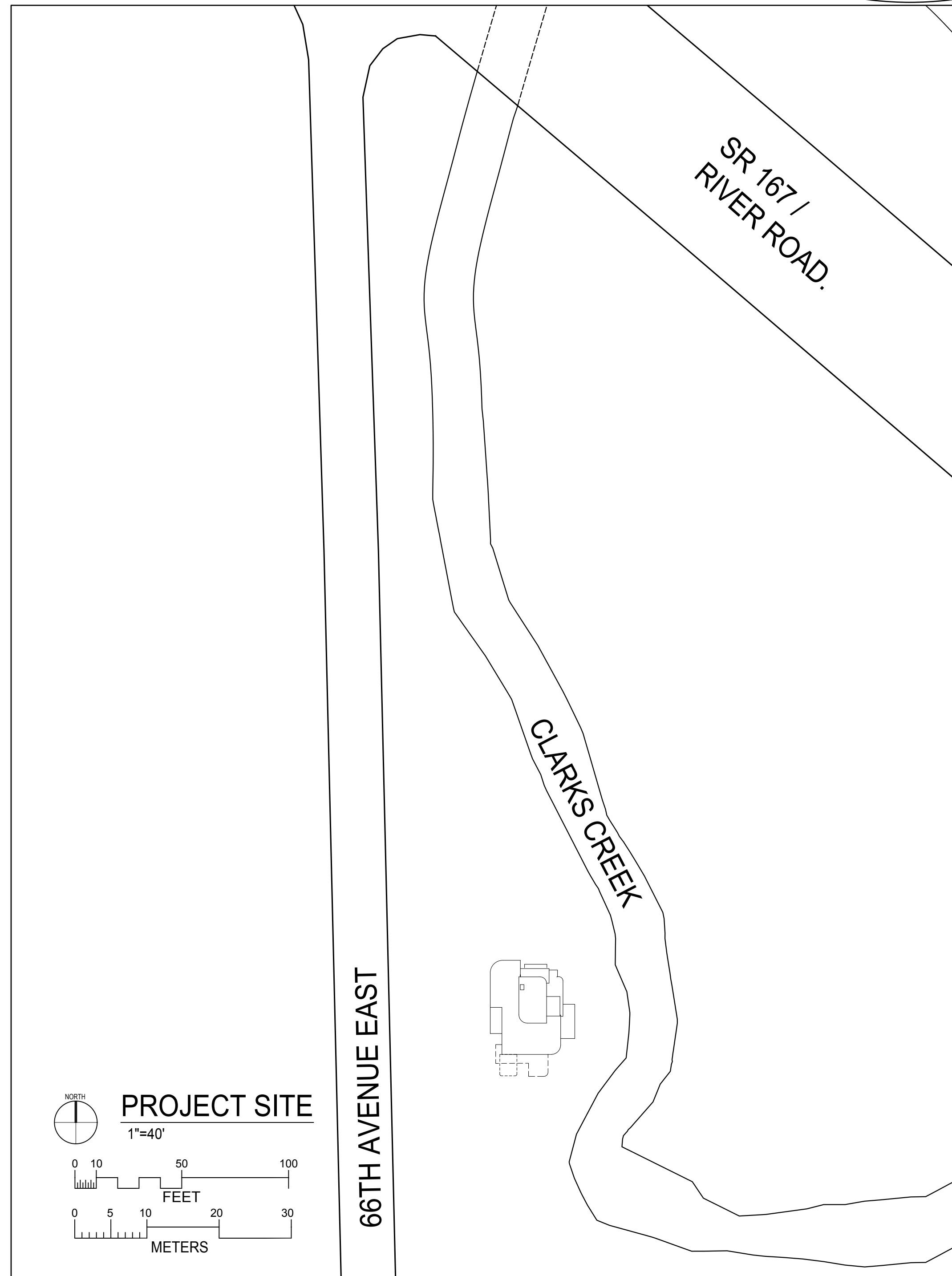
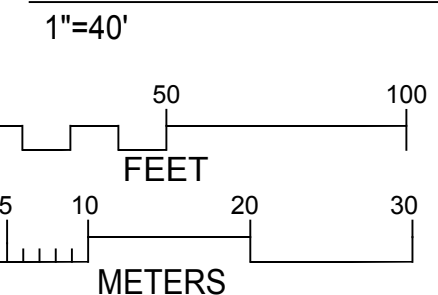

PHOTO CREDITS: PIERCE CC



PROJECT SITE



THE HOUSE OF TOMORROW

THE SMYSER RESIDENCE - PUYALLUP, WASHINGTON

THE HOUSE OF TOMORROW PROPERTY AT CLARK'S CREEK IS SIGNIFICANT AS THE WORK AND PRIMARY RESIDENCE OF BERT SMYSER, WINDOW DISPLAY DESIGNER AND AMATEUR ARCHITECTURAL DESIGNER. THE HOUSE IS REFLECTIVE OF SMYSER'S DESIGN SENSIBILITIES THAT ARE PRESENT ON OTHER BUILDINGS HE DESIGNED AND SHOWCASES MODERN MATERIALS AND HIS PREFERENCE FOR CURVES AND A STREAMLINED AESTHETIC OVER STRAIGHT OR HARD

EDGES. THE HOUSE'S STREAMLINE MODERNE DESIGN, BOTH WHEN IT WAS BUILT AND TODAY, STANDS IN STARK CONTRAST TO ITS SURROUNDING ENVIRONMENT. ALTHOUGH SMYSER DESIGNED SEVERAL BUILDINGS—HIS OWN RESIDENCE, HIS WORKSHOP AND OFFICE FOR SMYSER DISPLAY SERVICE (LATER A MOTEL, CA. 1927, 2016 S TACOMA WAY, TACOMA) CENTURY BALLROOM (1934, DESTROYED BY FIRE IN 1964), BOB'S JAVA JIVE (2102 S TACOMA WAY, TACOMA, 1929), AND

EXPOSITION HALL (1616 E 26TH STREET, TACOMA, 1940)—HIS PRIMARY CAREER WAS AS A DISPLAY DESIGNER, AND HIS WORK RANGED FROM WINDOW DISPLAYS TO PARADE FLOATS AND LARGE-SCALE EXHIBITION DESIGNS AT WORLD'S FAIRS REPRESENTING WASHINGTON STATE.

SHEET INDEX

- 1 - COVER SHEET (PROJECT LOCATION/VICINITY KEY/ PROJECT SITE/ TEXT/ SHEET LIST)
- 2 - ENLARGED SITE PLAN / SITE SECTIONS
- 3 - SITE PROFILES, SITE DETAILS
- 4 - AXONOMETRIC VIEWS
- 5 - LOWER FLOOR PLANS
- 6 - LOWER FLOOR SPOT ELEVATIONS
- 7 - MAIN FLOOR PLANS
- 8 - MAIN FLOOR SPOT ELEVATIONS
- 9 - UPPER FLOOR PLANS
- 10 - UPPER FLOOR SPOT ELEVATIONS
- 11 - ROOF PLAN, ROOF SPOT ELEVATIONS
- 12 - EXTERIOR ELEVATIONS
- 13 - BUILDING SECTIONS
- 14 - INTERIOR ELEVATIONS
- 15 - CABINET SECTIONS
- 16 - CABINET SECTIONS AND DETAILS

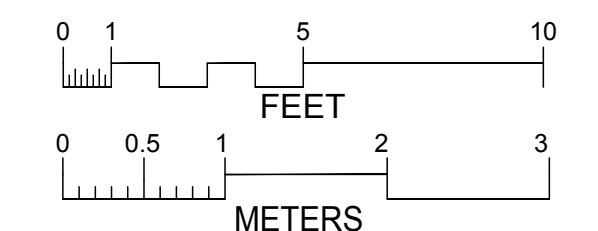

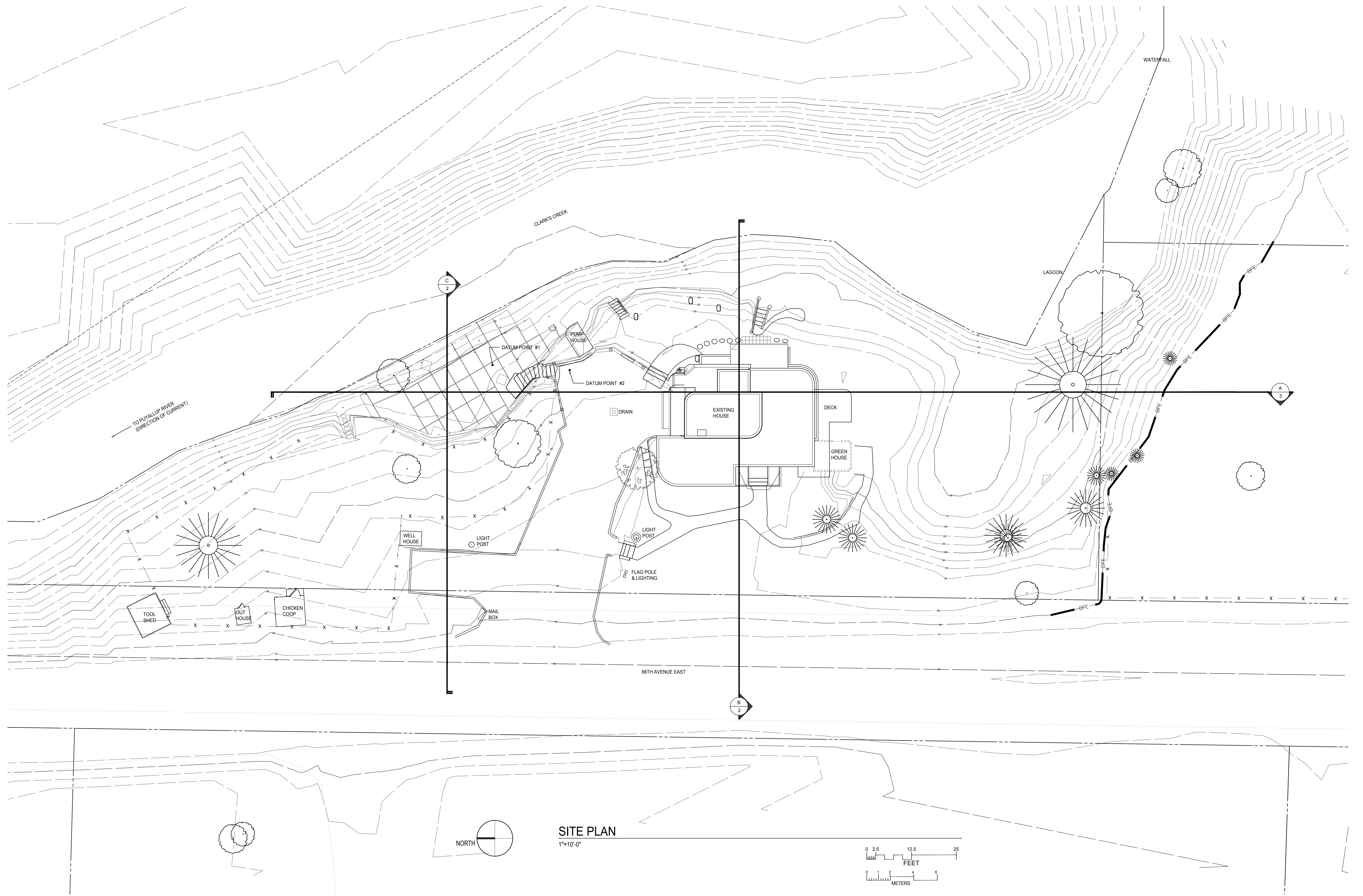

SITE PLAN
1"=10'-0"

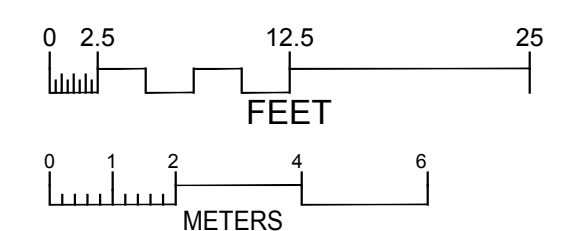

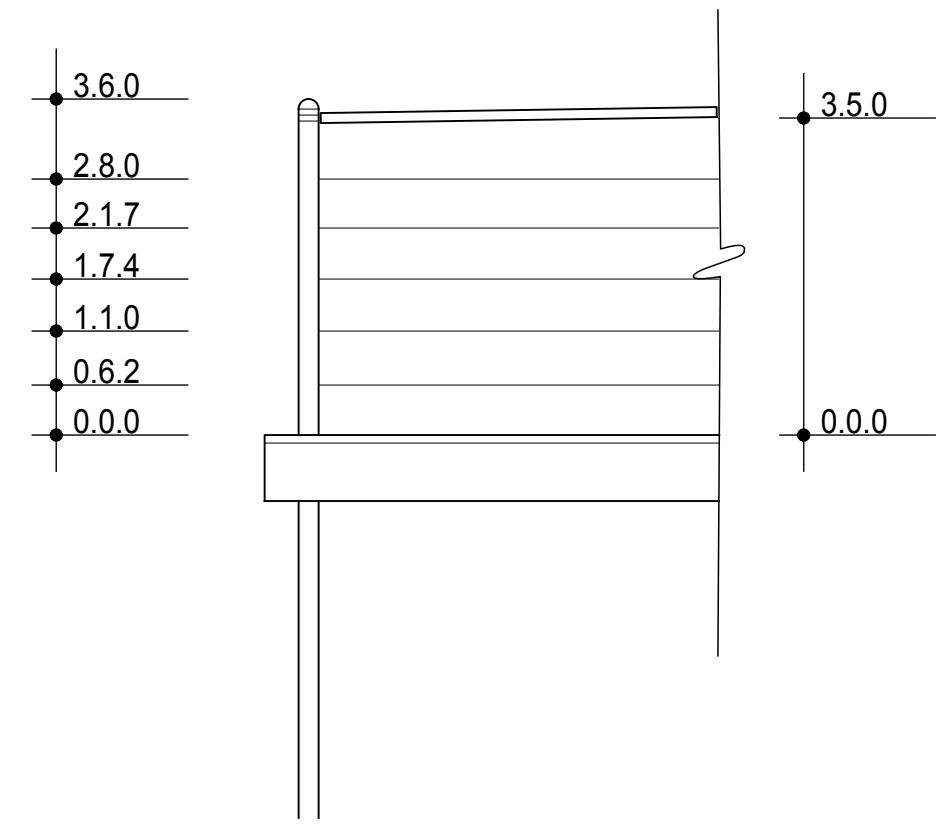

1 DETAIL: DECK RAILING
1/2" = 1'-0"

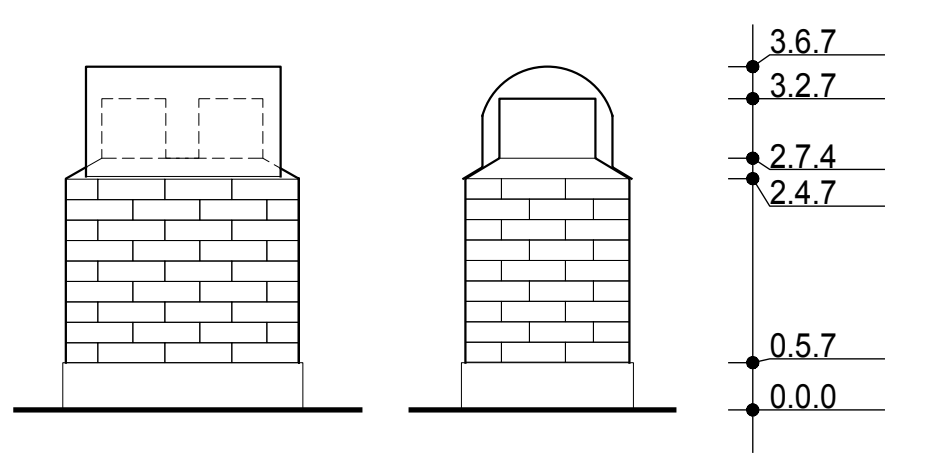

2 DETAIL: CHIMNEY
1/2" = 1'-0"

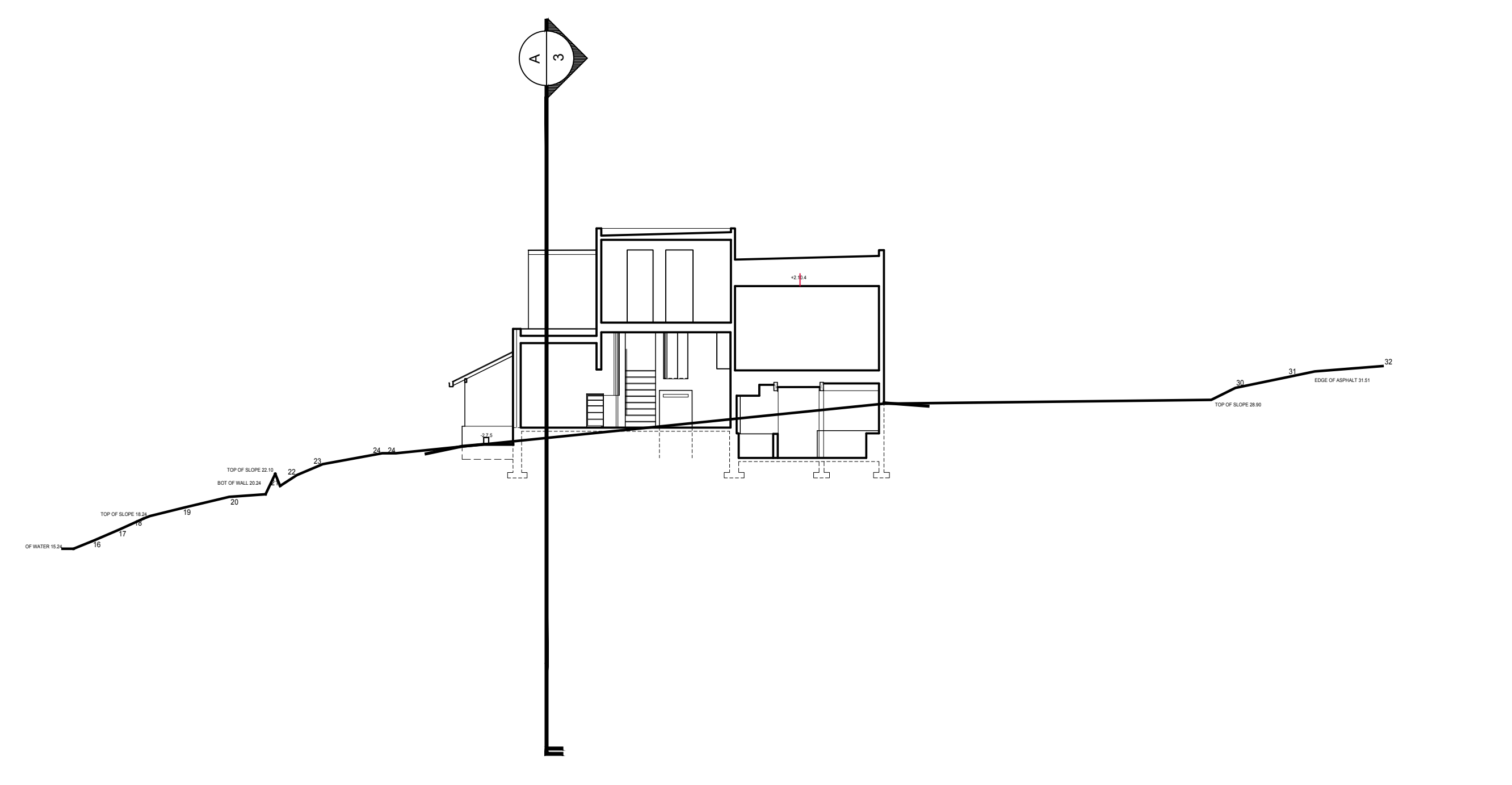

B SITE PROFILE
1" = 10'-0"

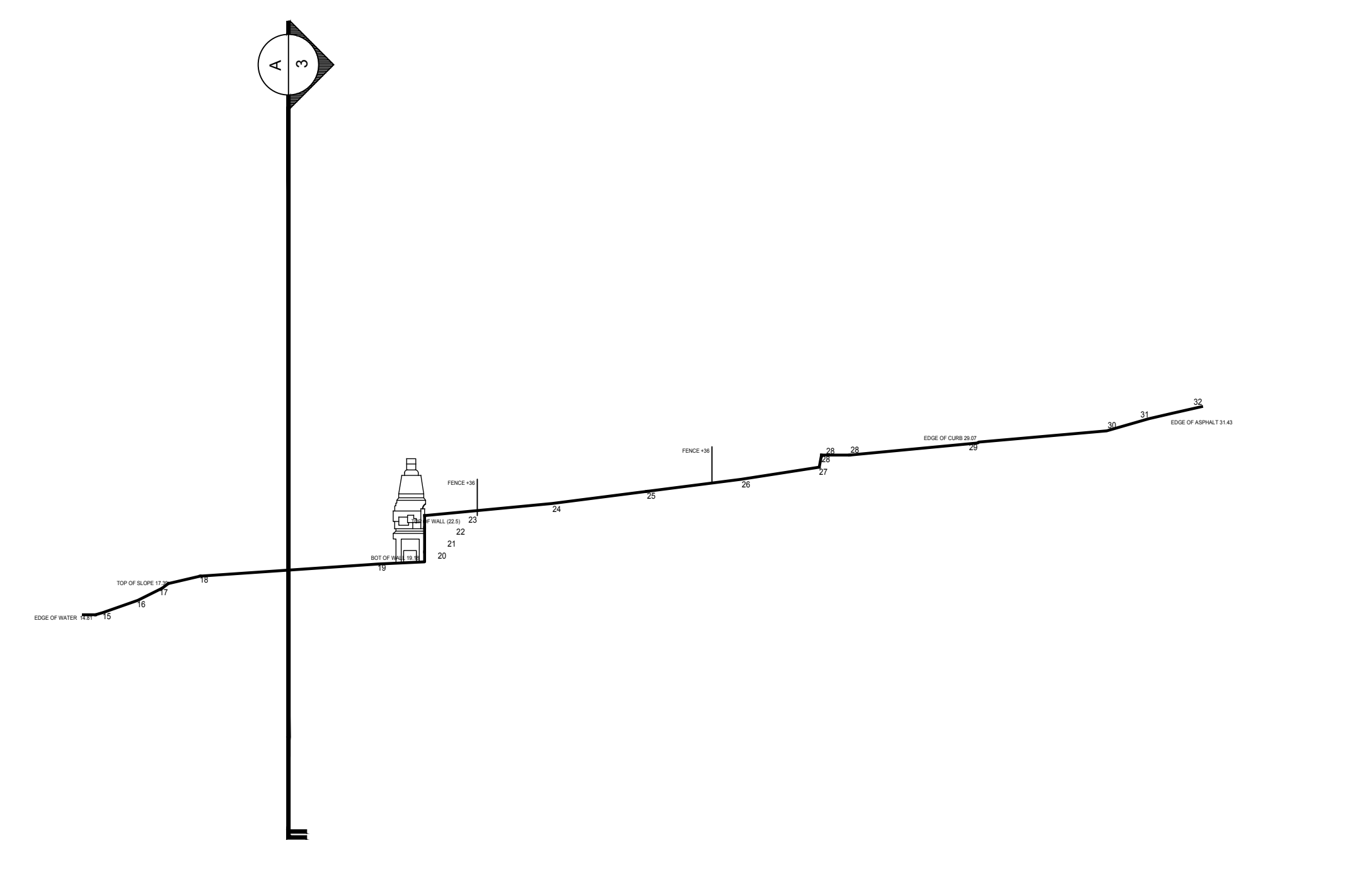

C SITE PROFILE
1" = 10'-0"

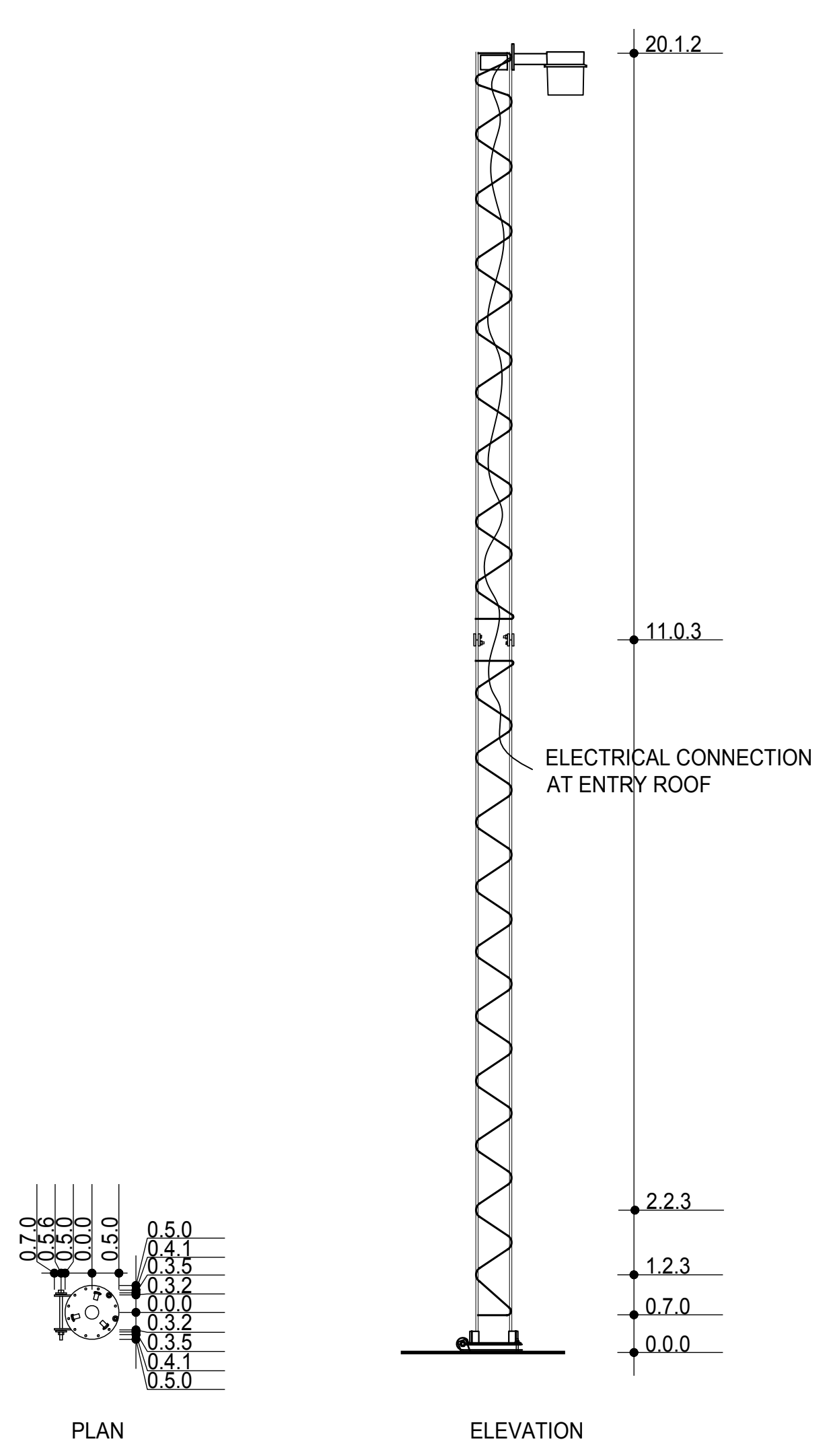

3 DETAIL: LIGHTPOLE
1/2" = 1'-0"

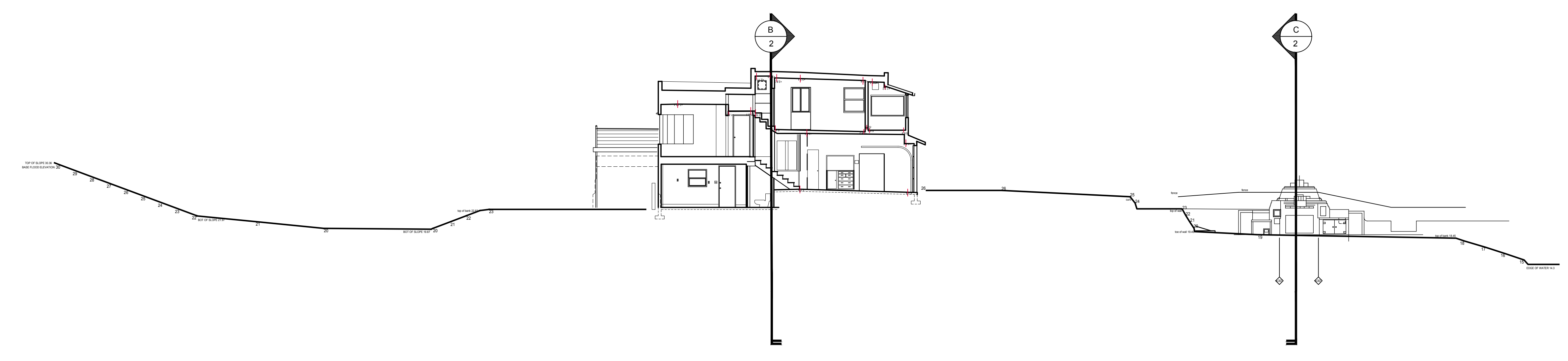

A SITE PROFILE
1" = 10'-0"

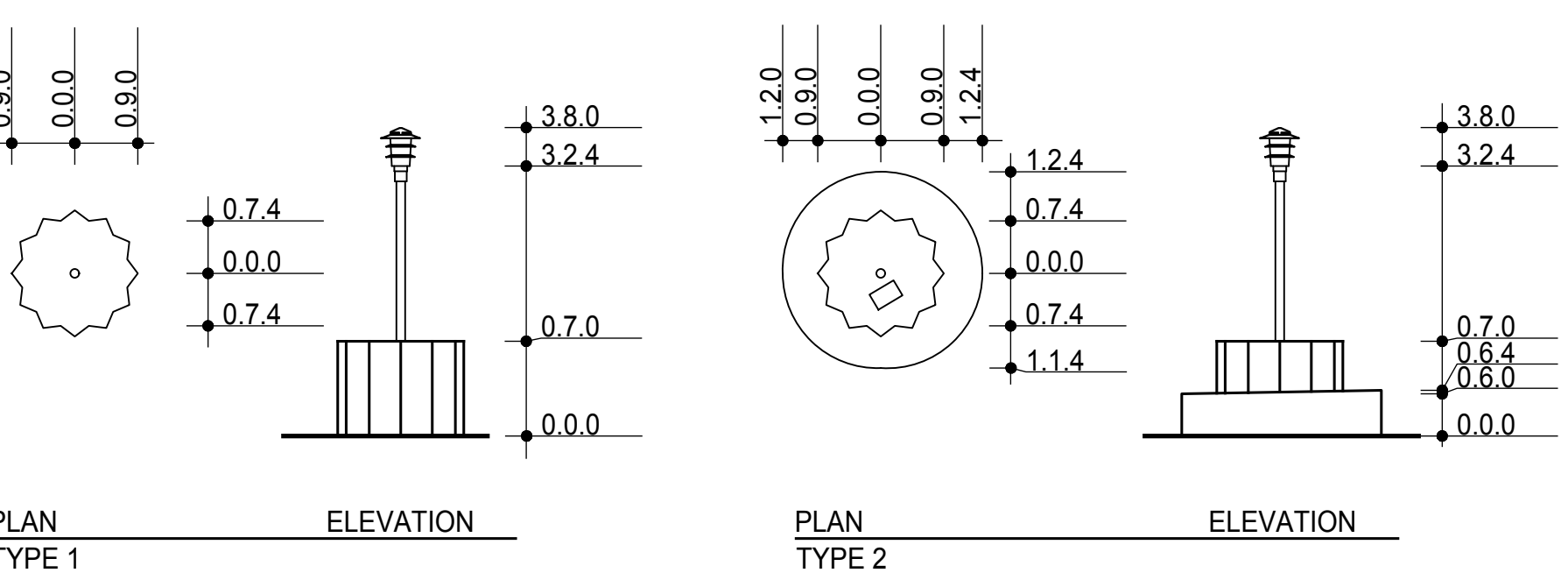

4 DETAIL: LANDSCAPE LIGHTS
1/2" = 1'-0"

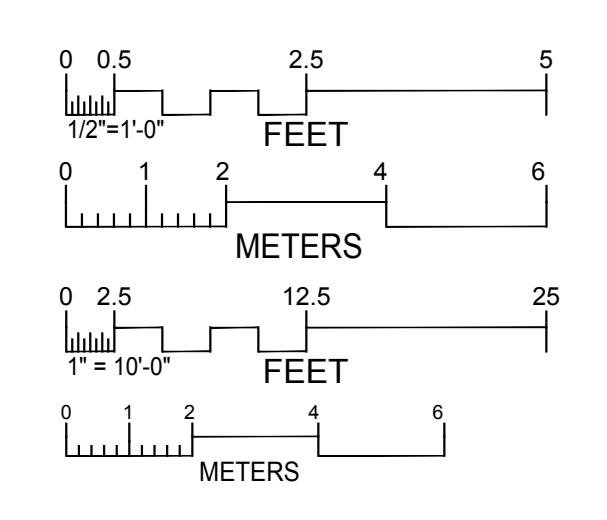

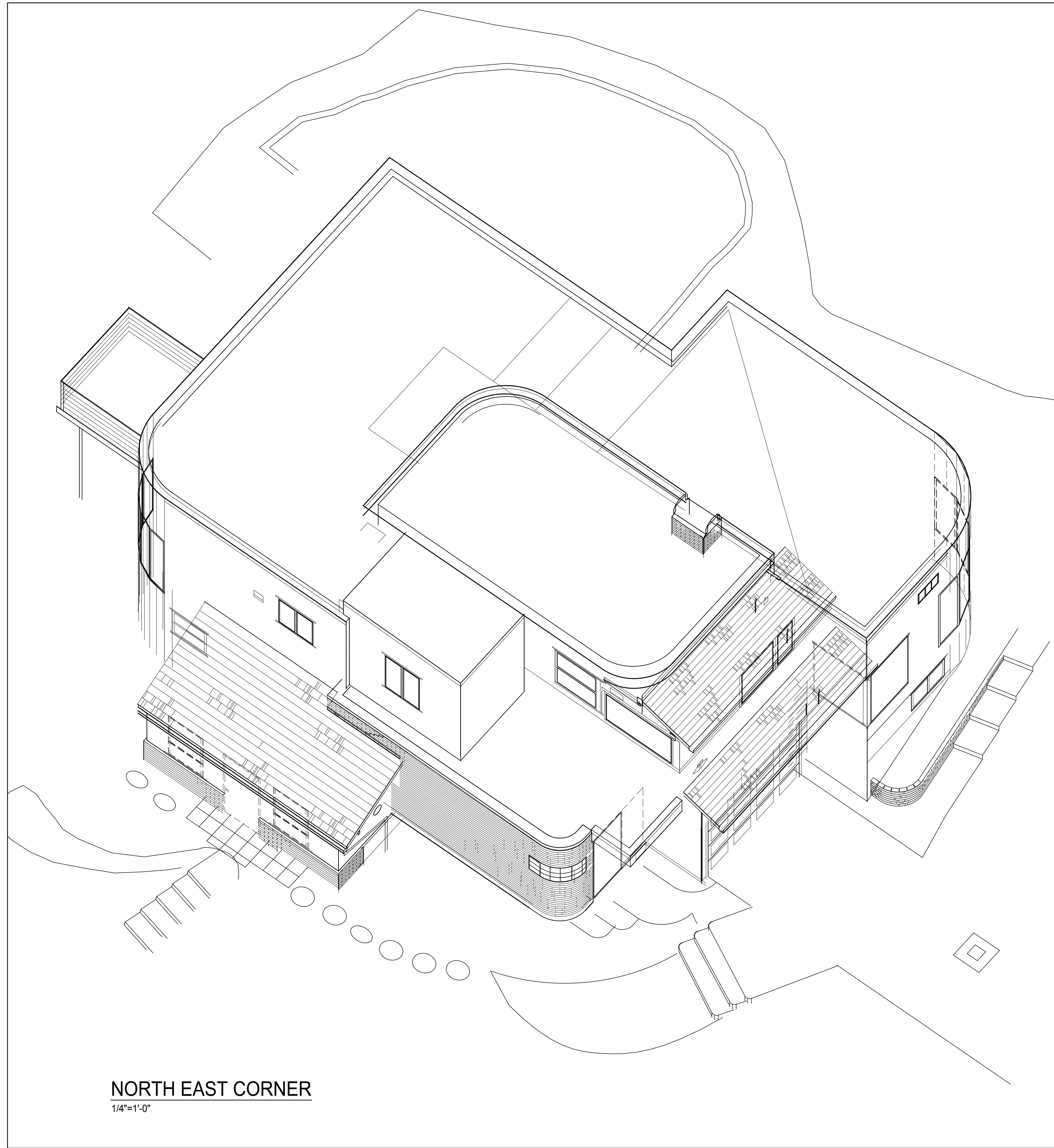

NORTH EAST CORNER
1/4"=1'-0"

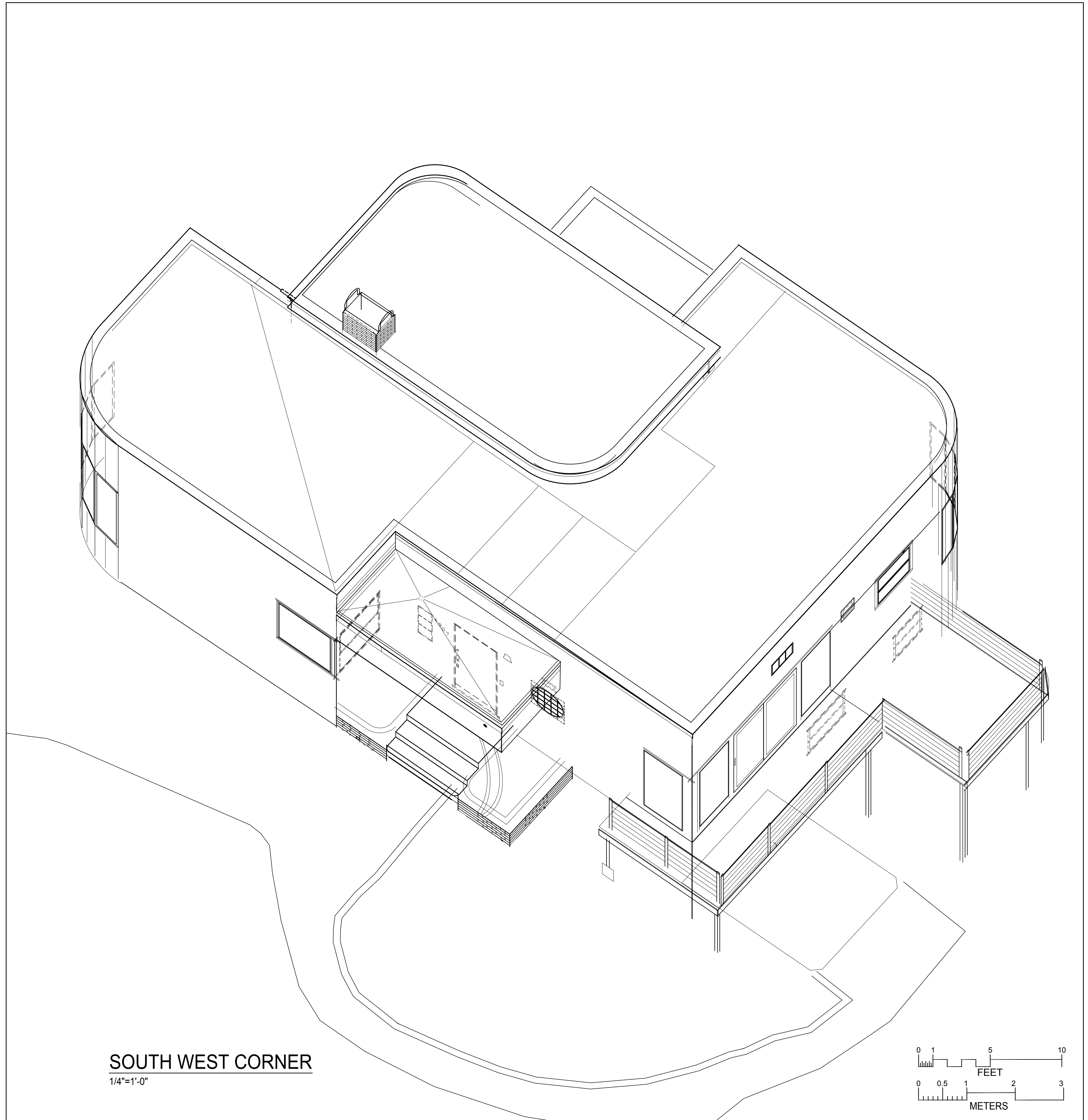

SOUTH WEST CORNER
1/4"=1'-0"

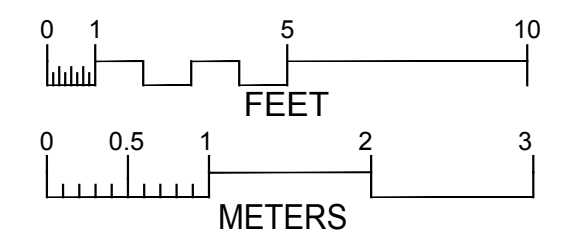

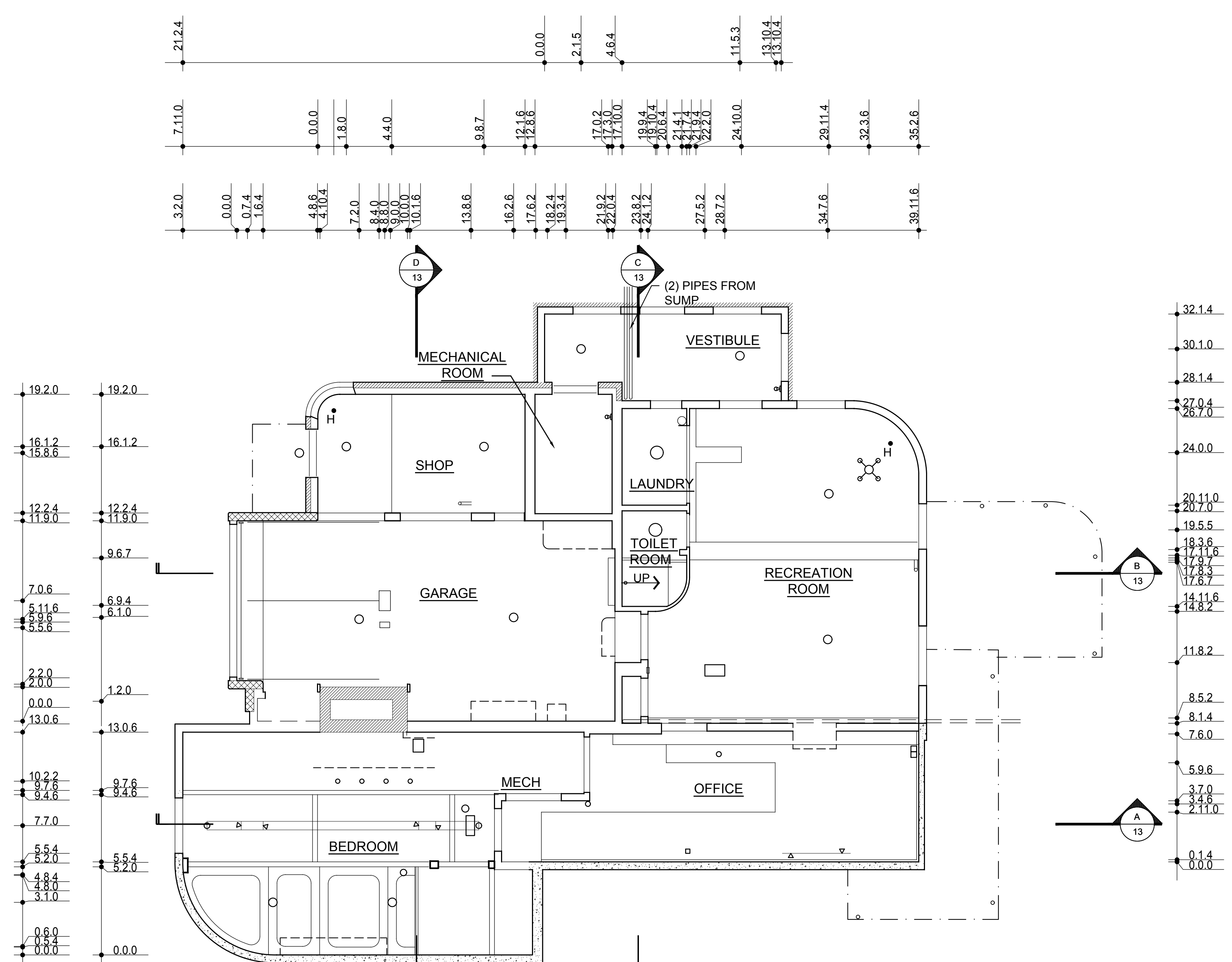

LOWER FLOOR REFLECTED CEILING PLAN
1/4"=1'-0"

32.14	32.14
30.10	29.81
28.14	27.87
27.04	26.70
24.00	24.40
20.11.0	21.70
19.55	18.90
18.3.6	17.8.4
17.1.6	
17.8.3	
17.6.7	
14.11.6	
13.0.4	
11.8.2	
8.5.2	8.5.2
8.1.4	8.1.4
7.6.0	7.8.0
6.10.4	
6.3.6	
5.9.6	
3.7.0	
2.4.9	
2.1.1.0	
0.1.4	
0.0.0	

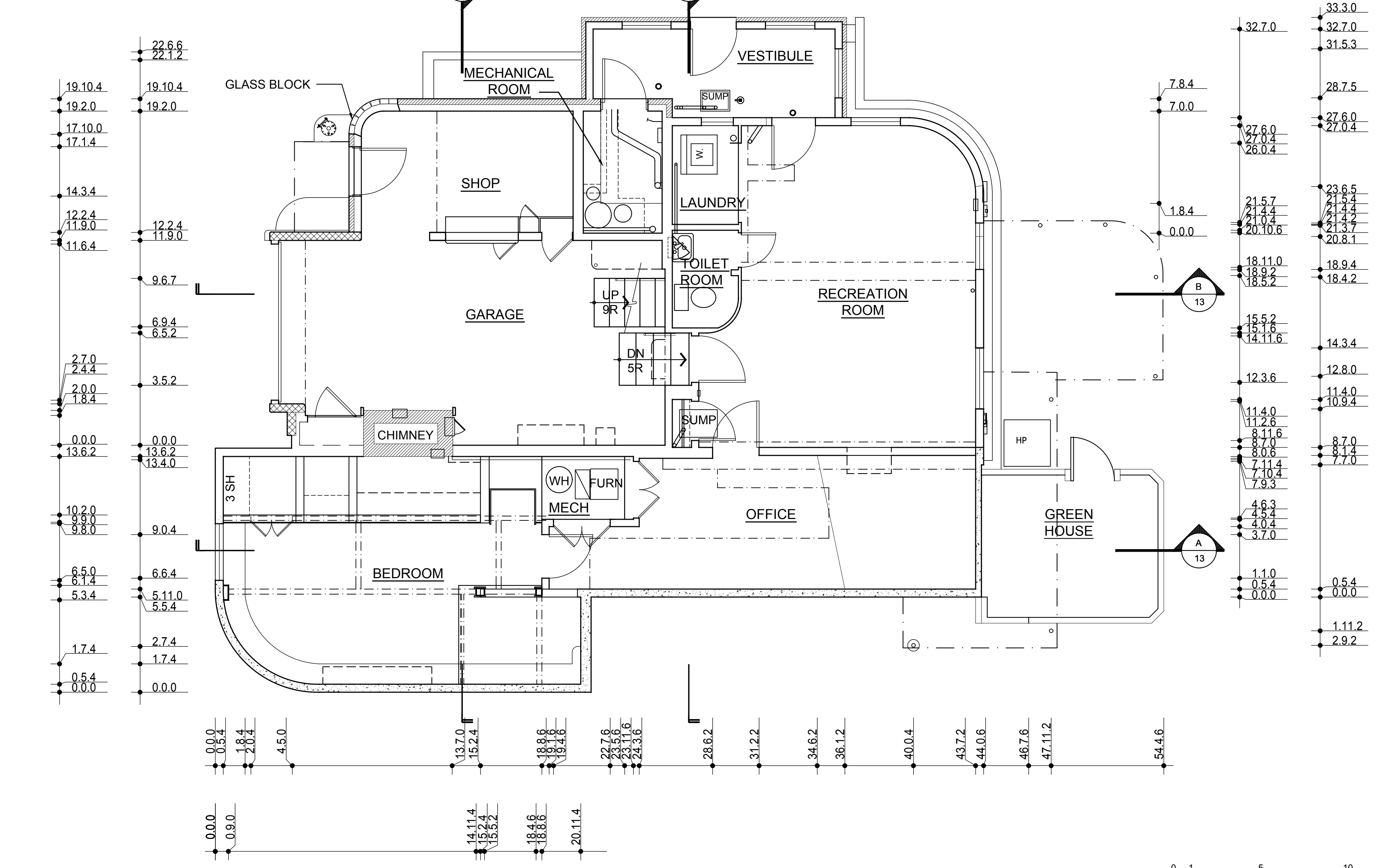
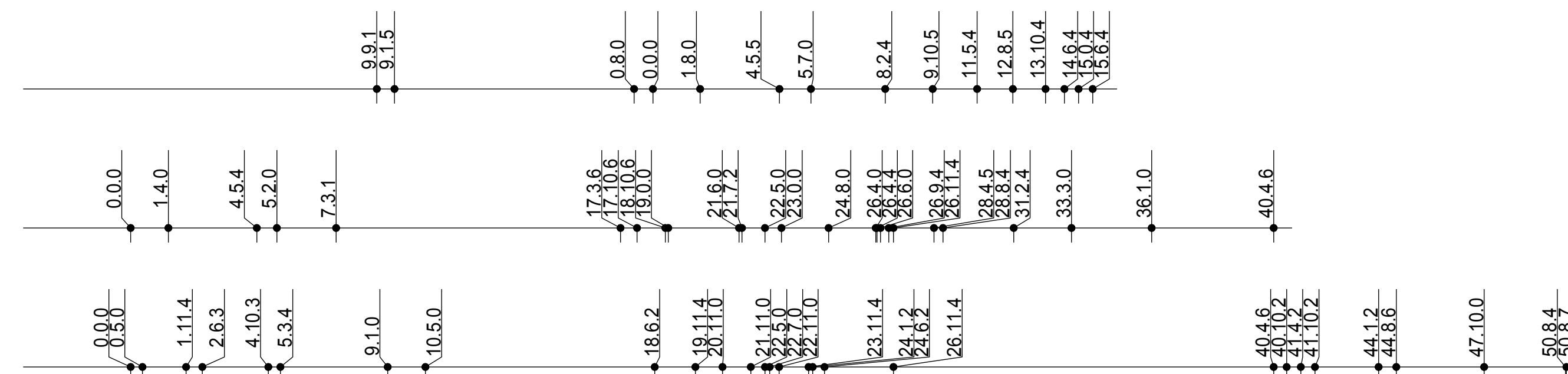

LOWER FLOOR PLAN
1/4"=1'-0"

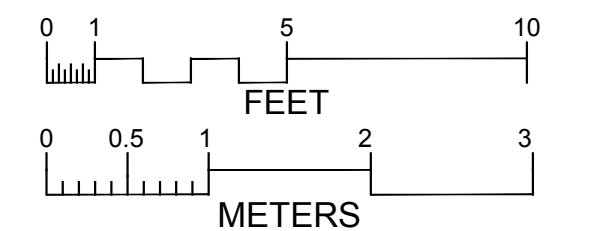

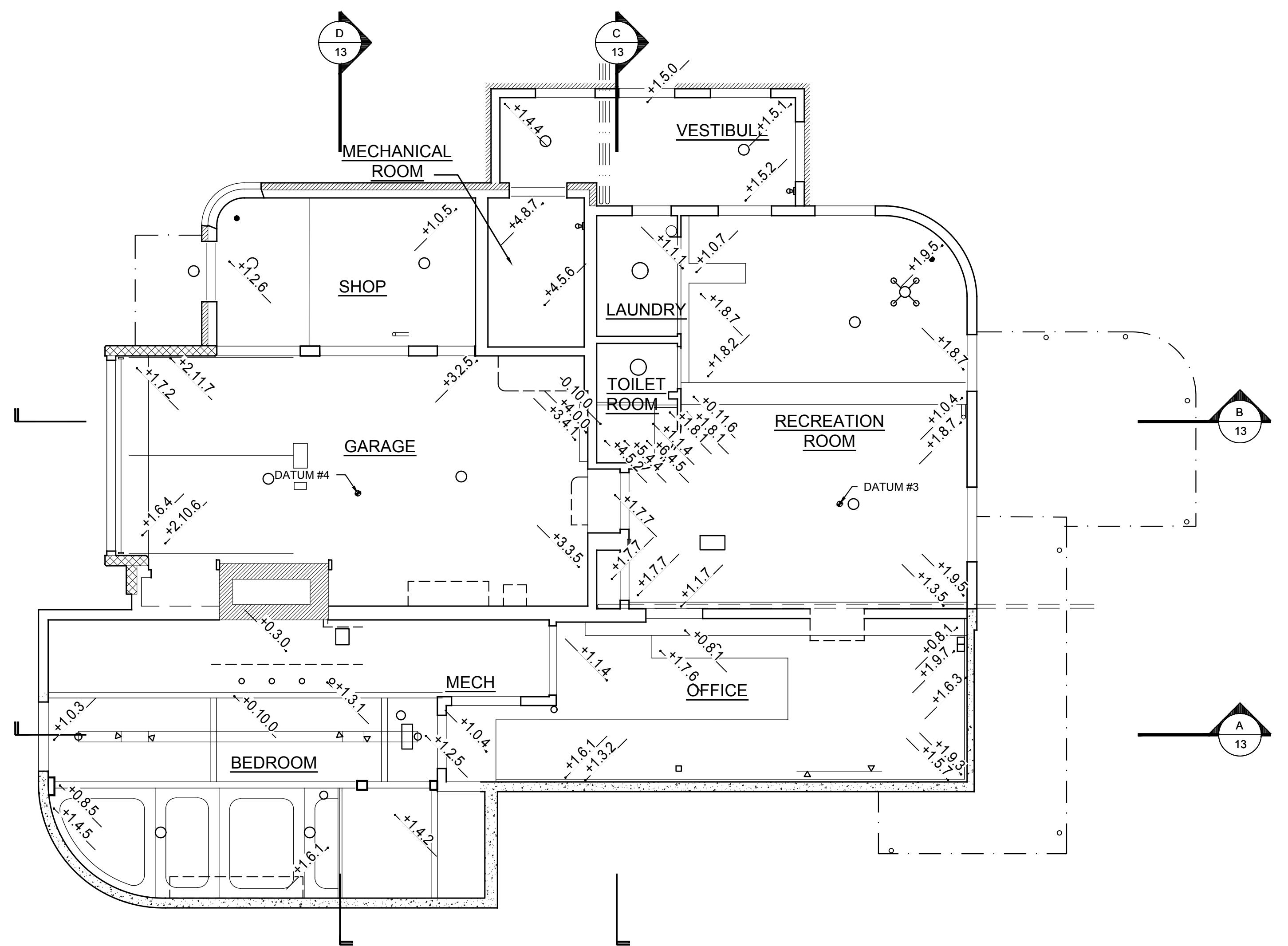

LOWER FLOOR REFLECTED CEILING PLAN - SPOT ELEVATIONS
 1/4"=1'-0"

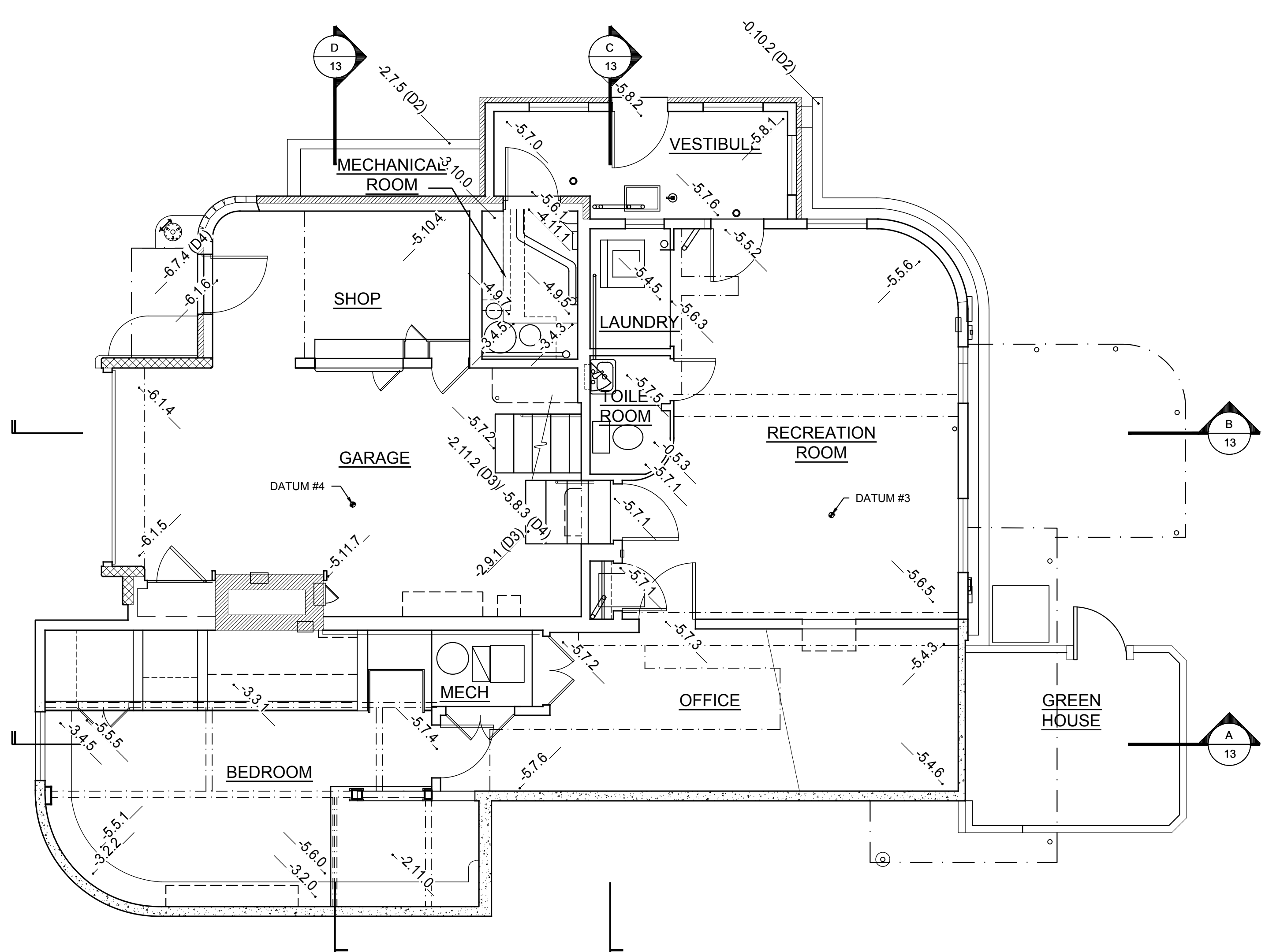

LOWER FLOOR PLAN - SPOT ELEVATIONS
 1/4"=1'-0"

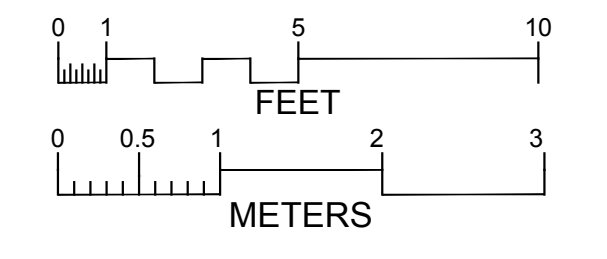

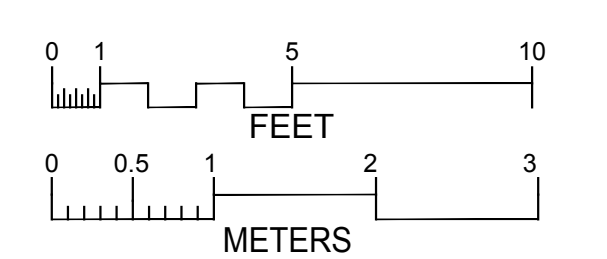
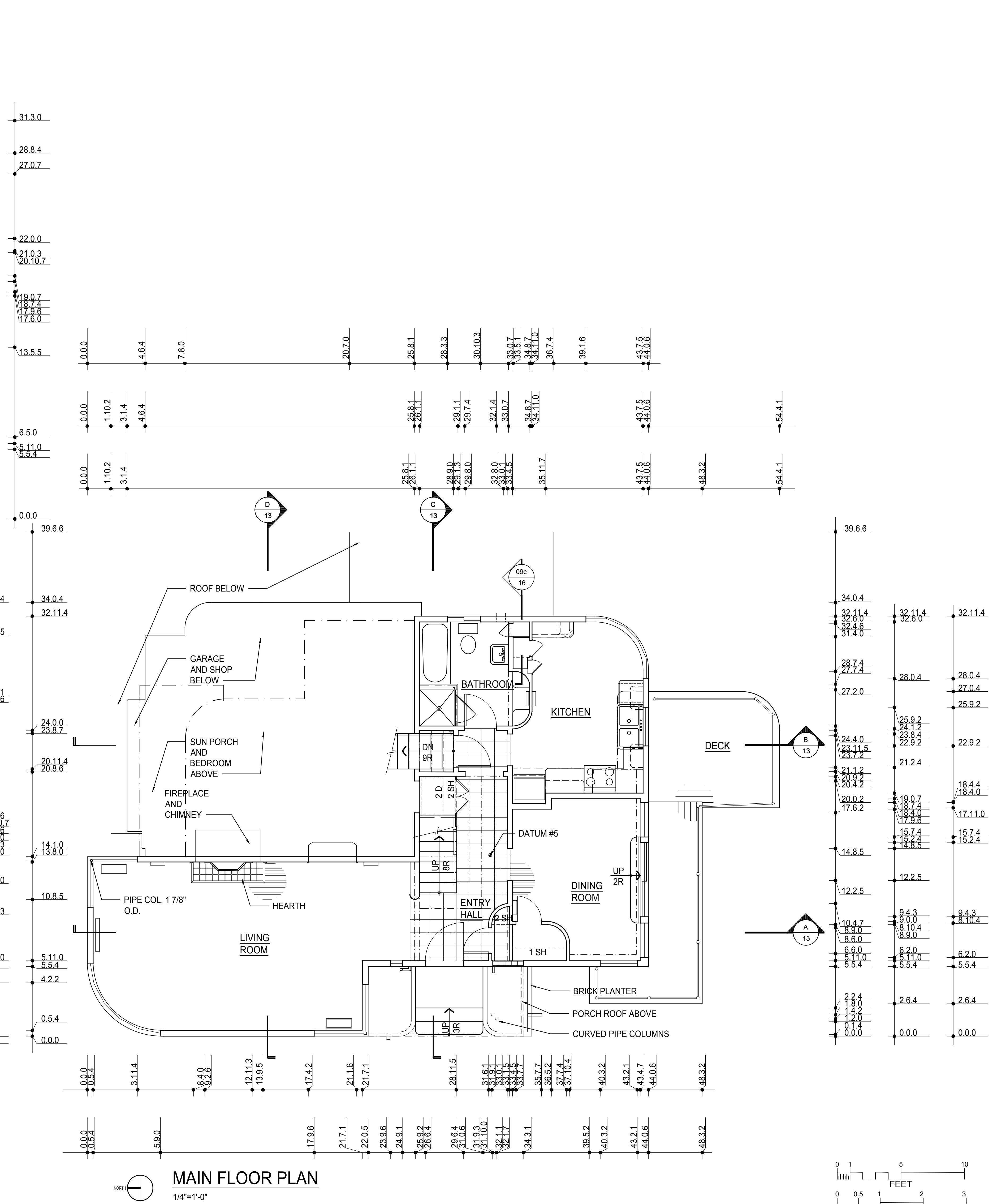
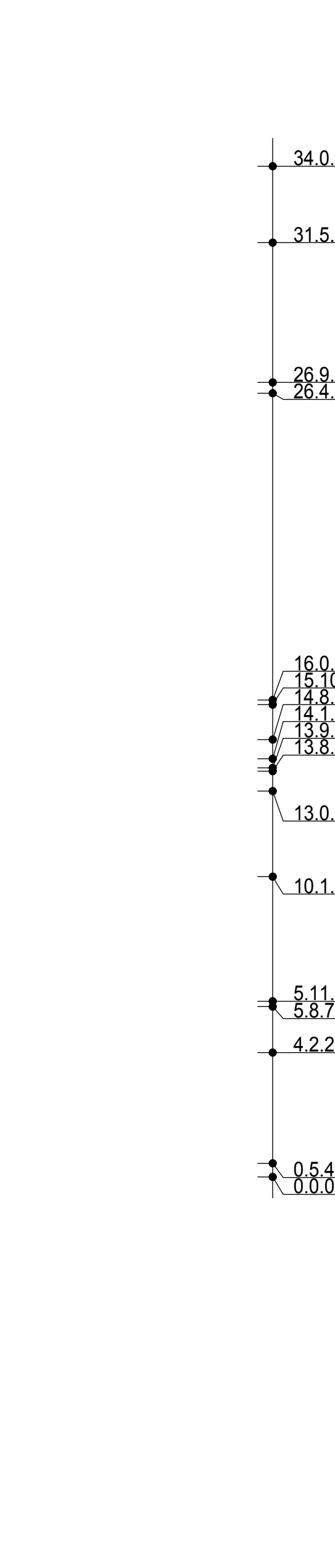
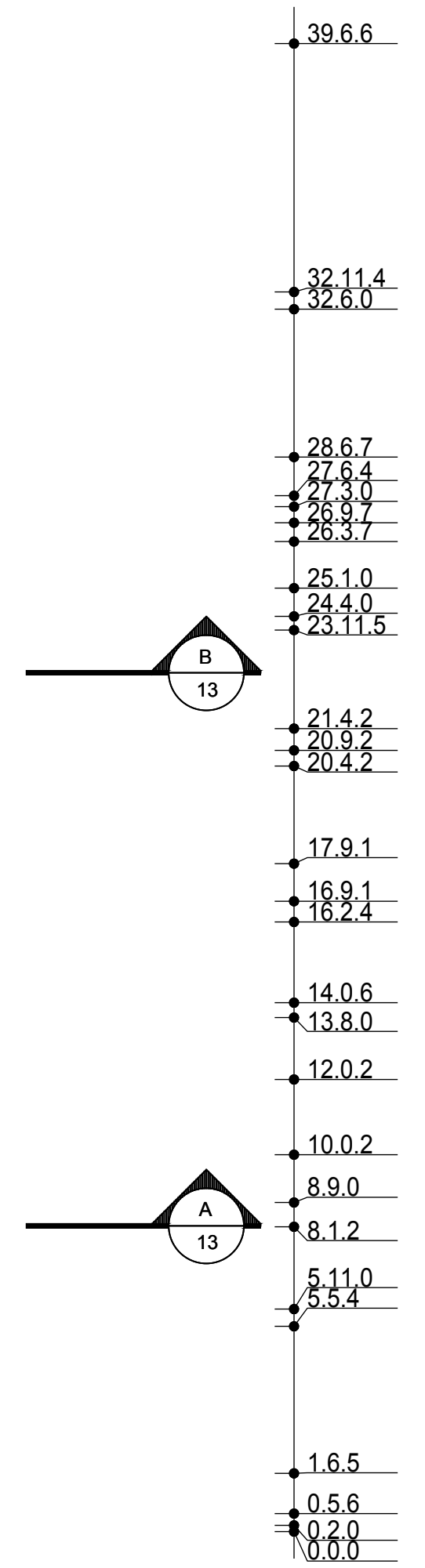
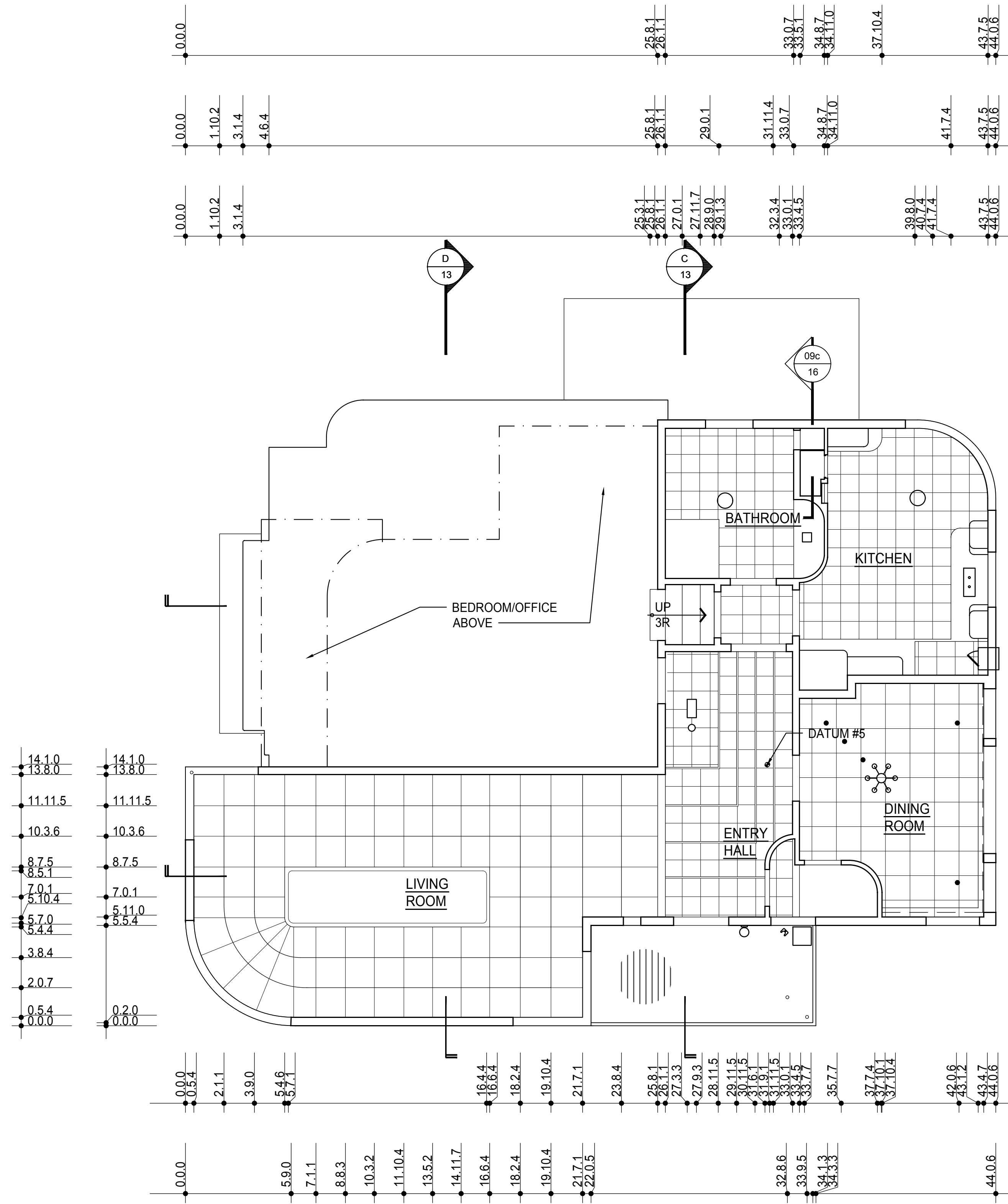

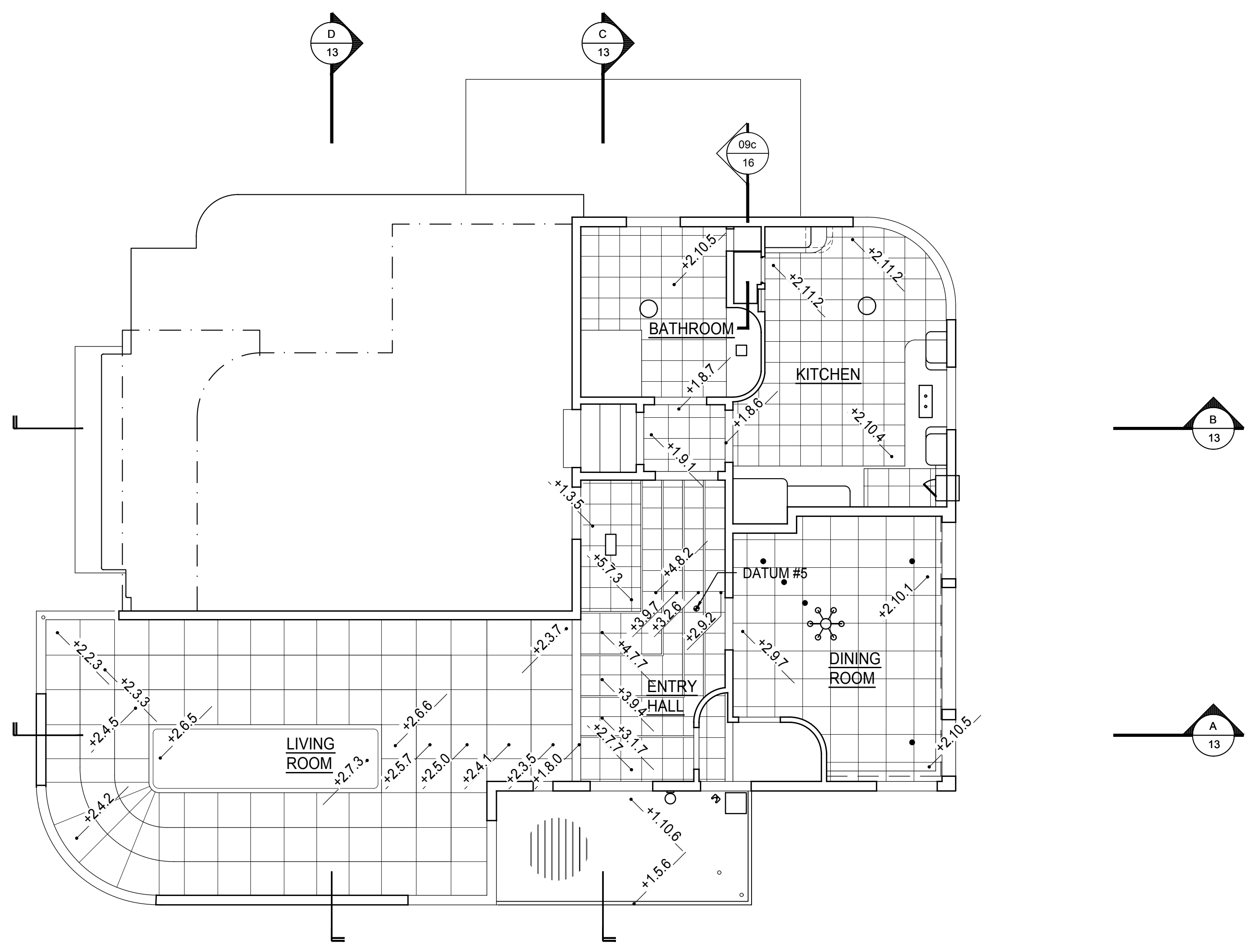

MAIN FLOOR REFLECTED CEILING PLAN - SPOT ELEVATIONS
1/4"=1'-0"

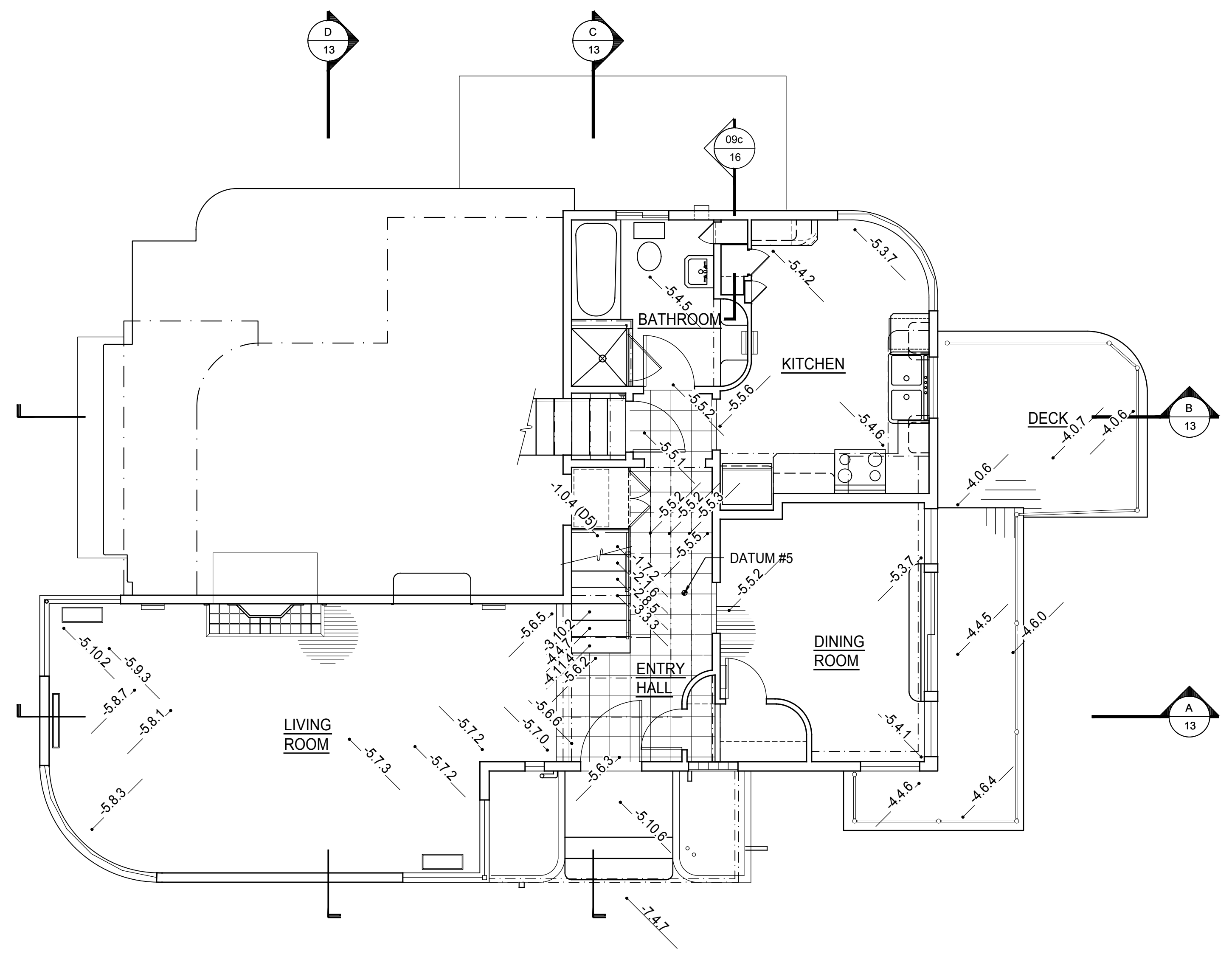

MAIN FLOOR PLAN - SPOT ELEVATIONS
1/4"=1'-0"

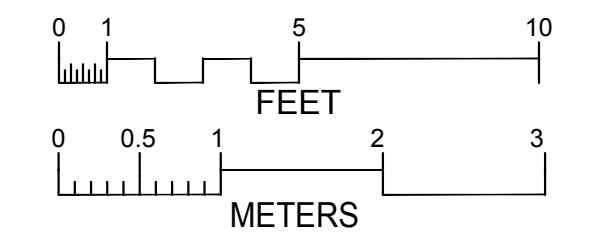

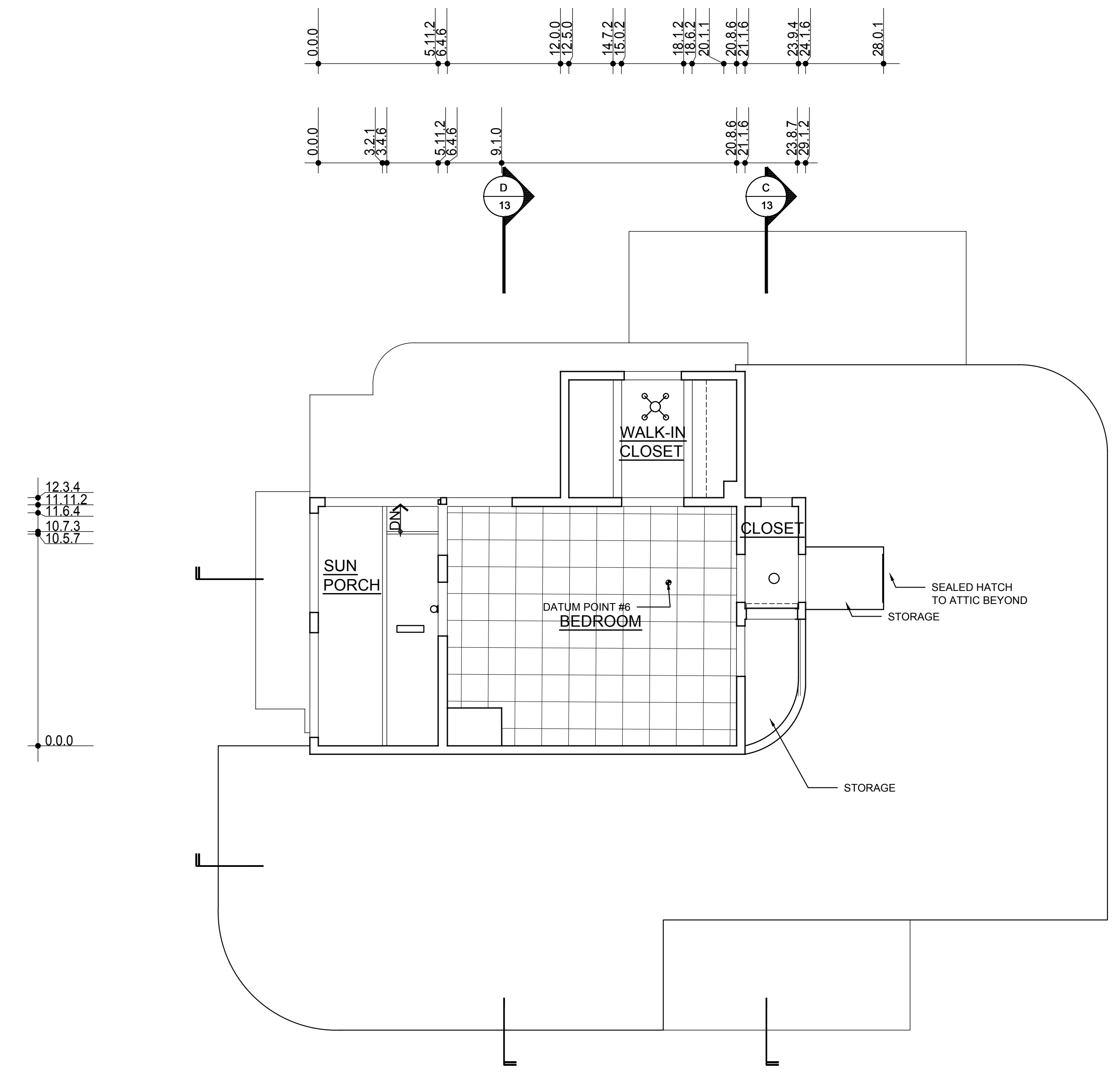

UPPER FLOOR REFLECTED CEILING PLAN
1/4"=1'-0"

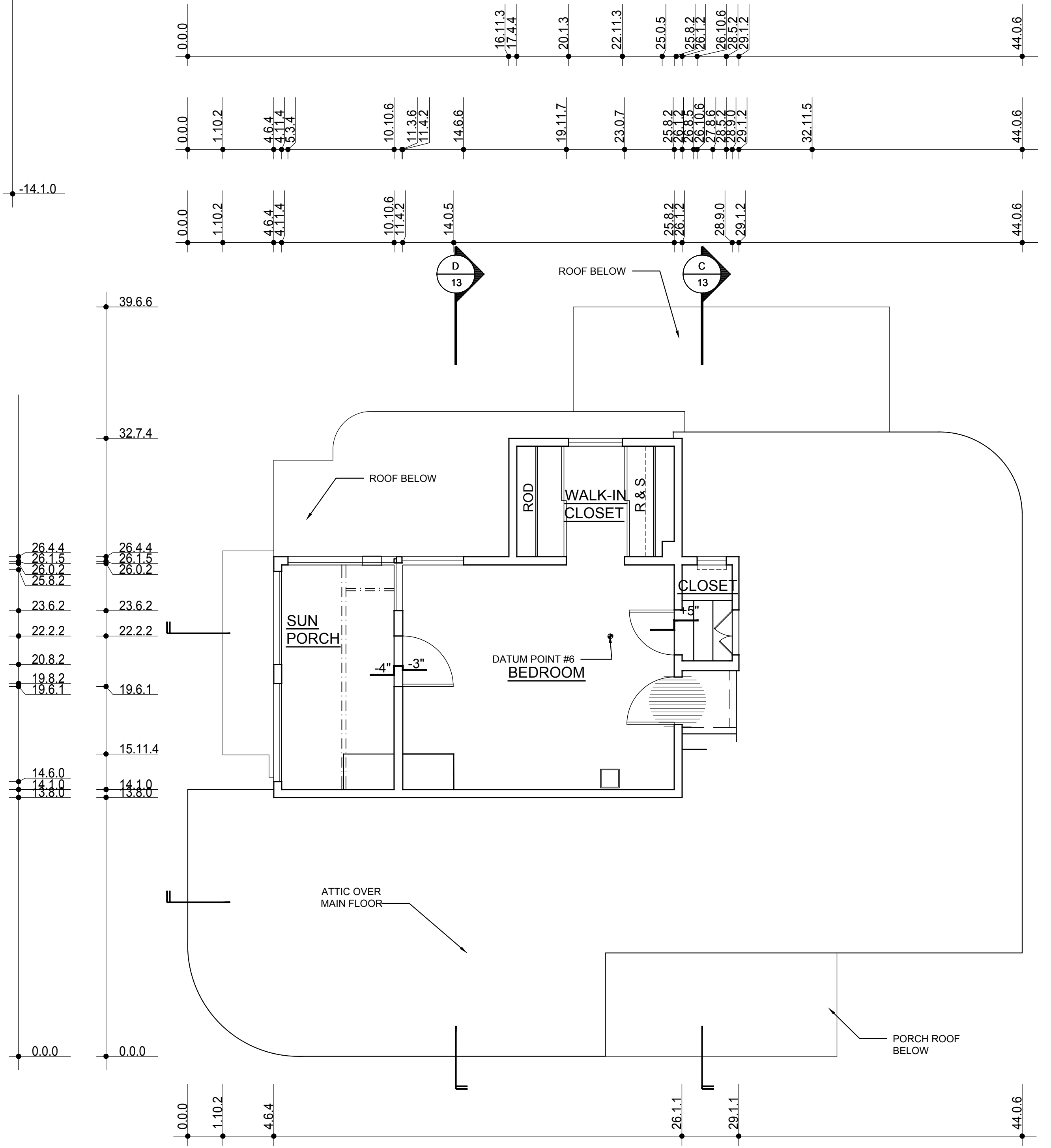
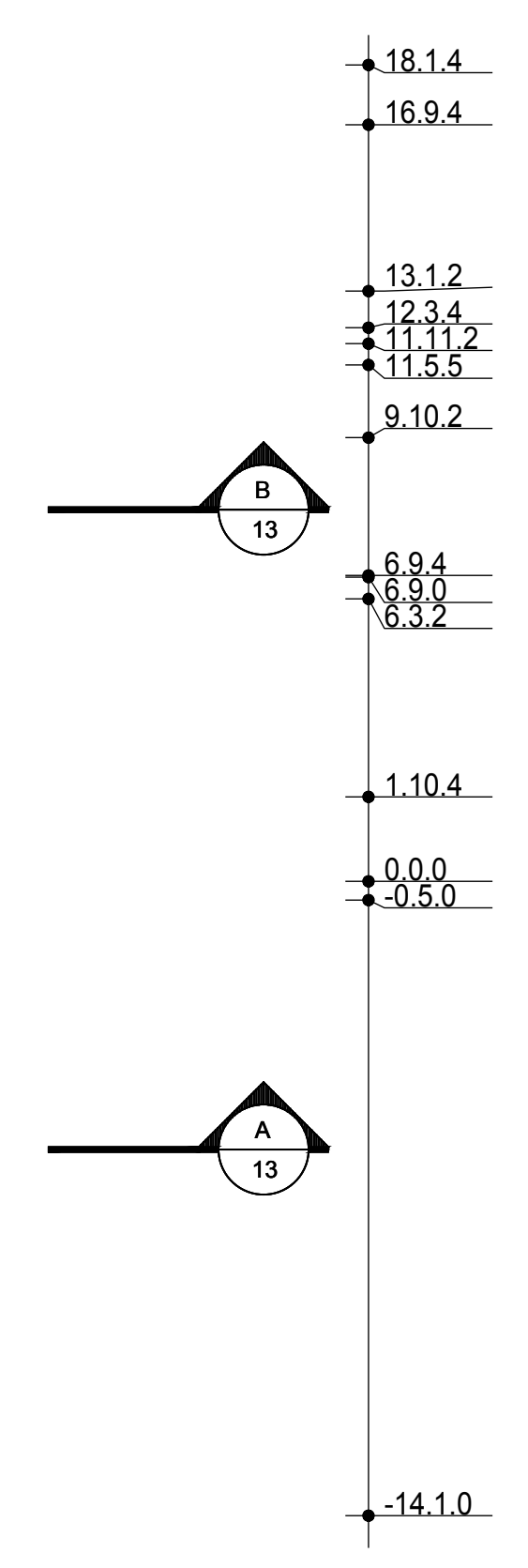

UPPER FLOOR PLAN
1/4"=1'-0"

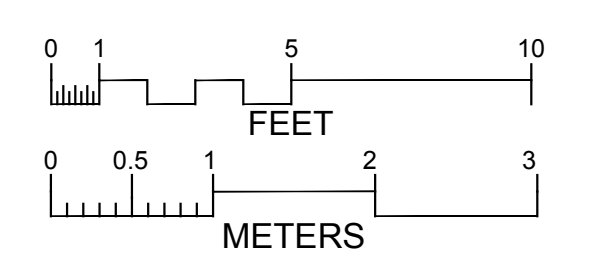
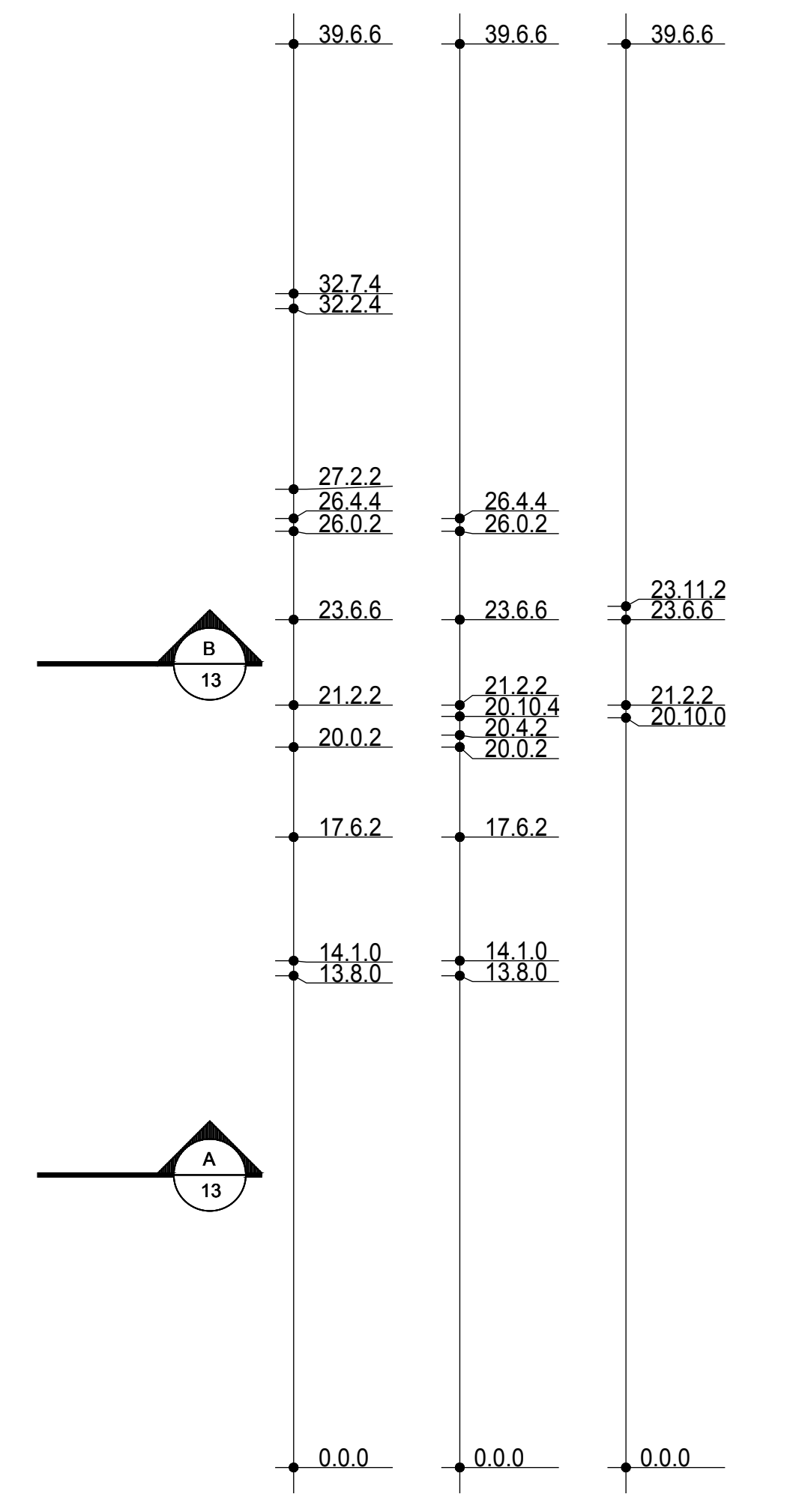
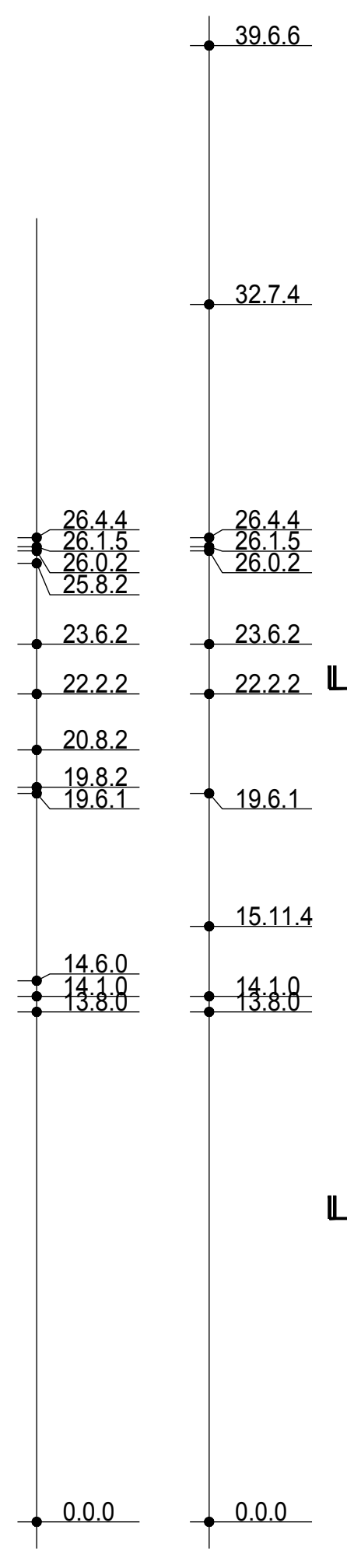

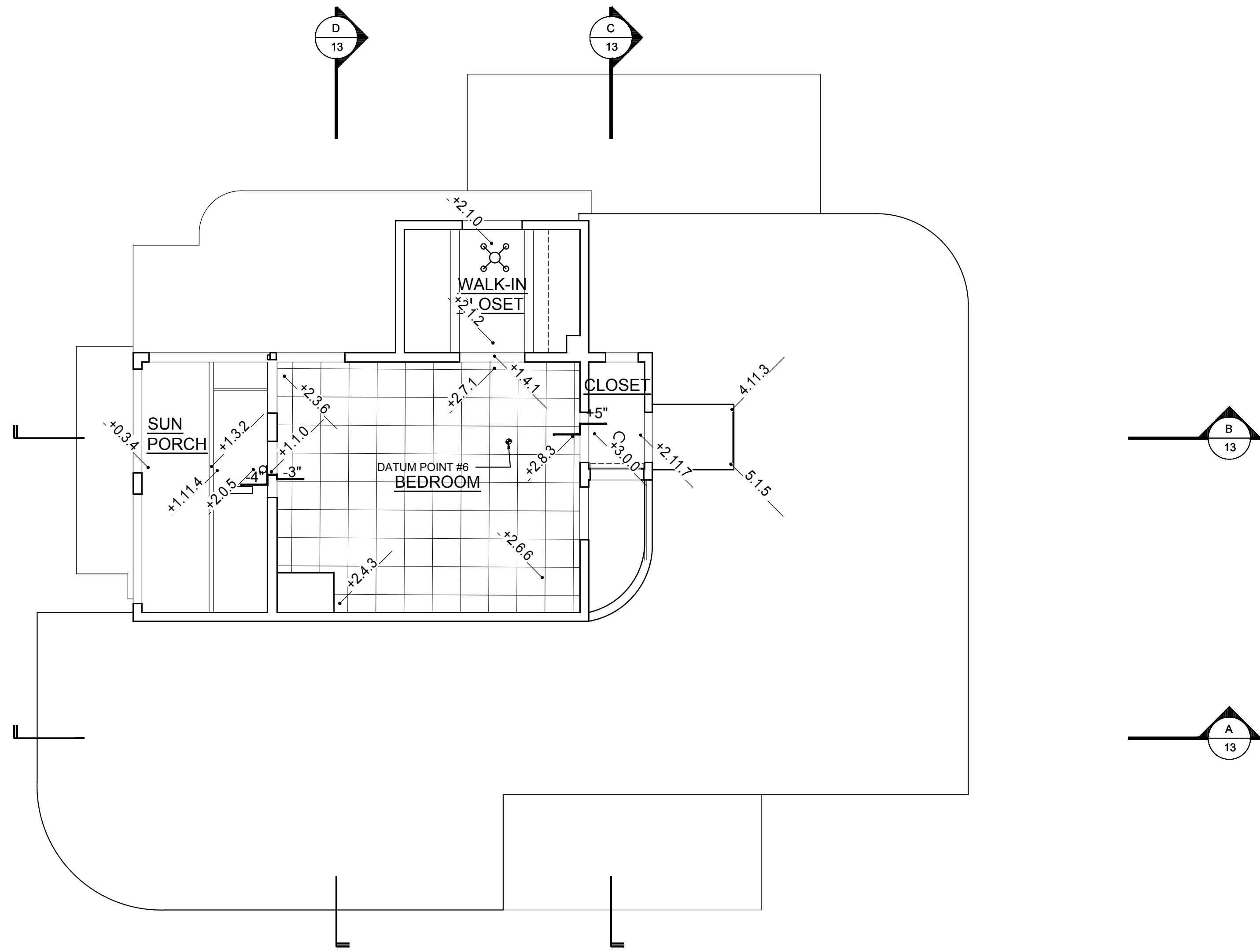

UPPER FLOOR REFLECTED CEILING PLAN - SPOT ELEVATIONS
1/4"=1'-0"

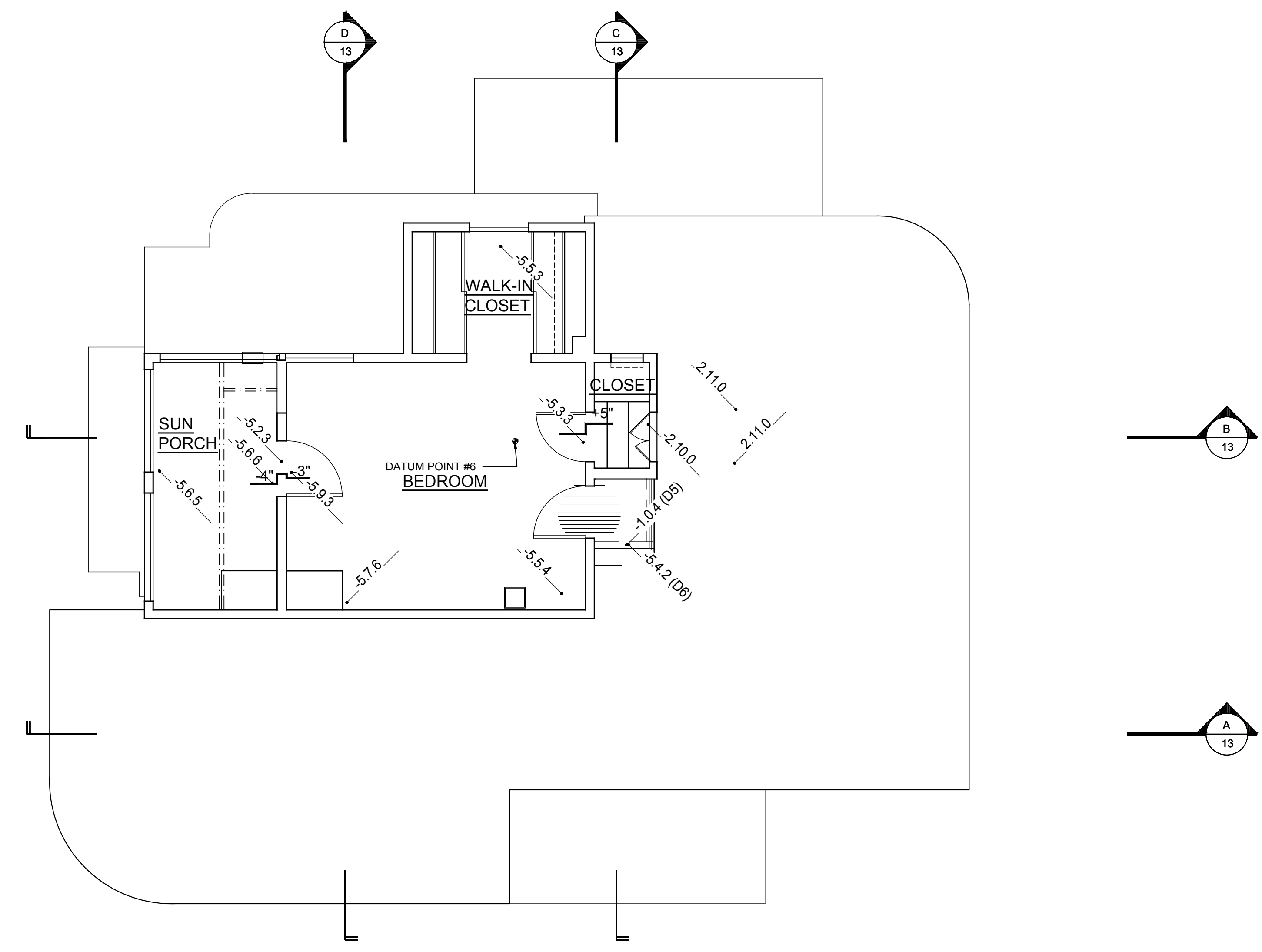

UPPER FLOOR PLAN - ADDITIONAL DIMENSIONS
1/4"=1'-0"

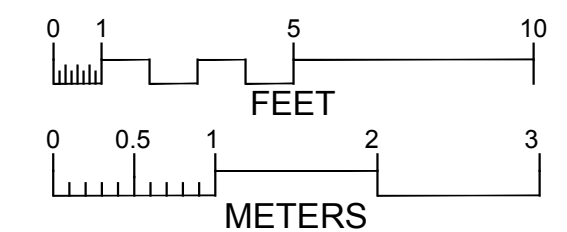

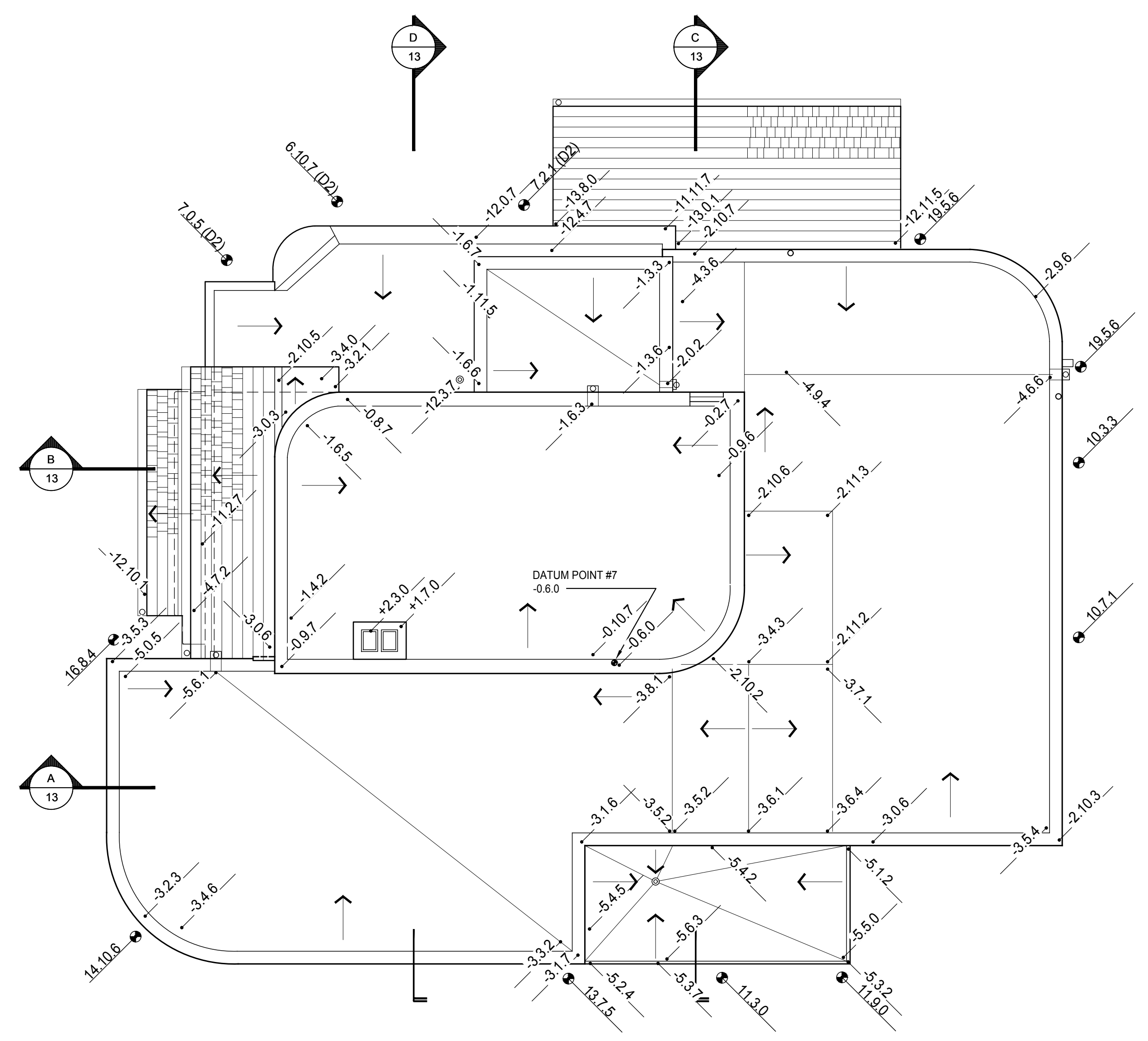

ROOF PLAN - SPOT ELEVATIONS
1/4"=1'-0"

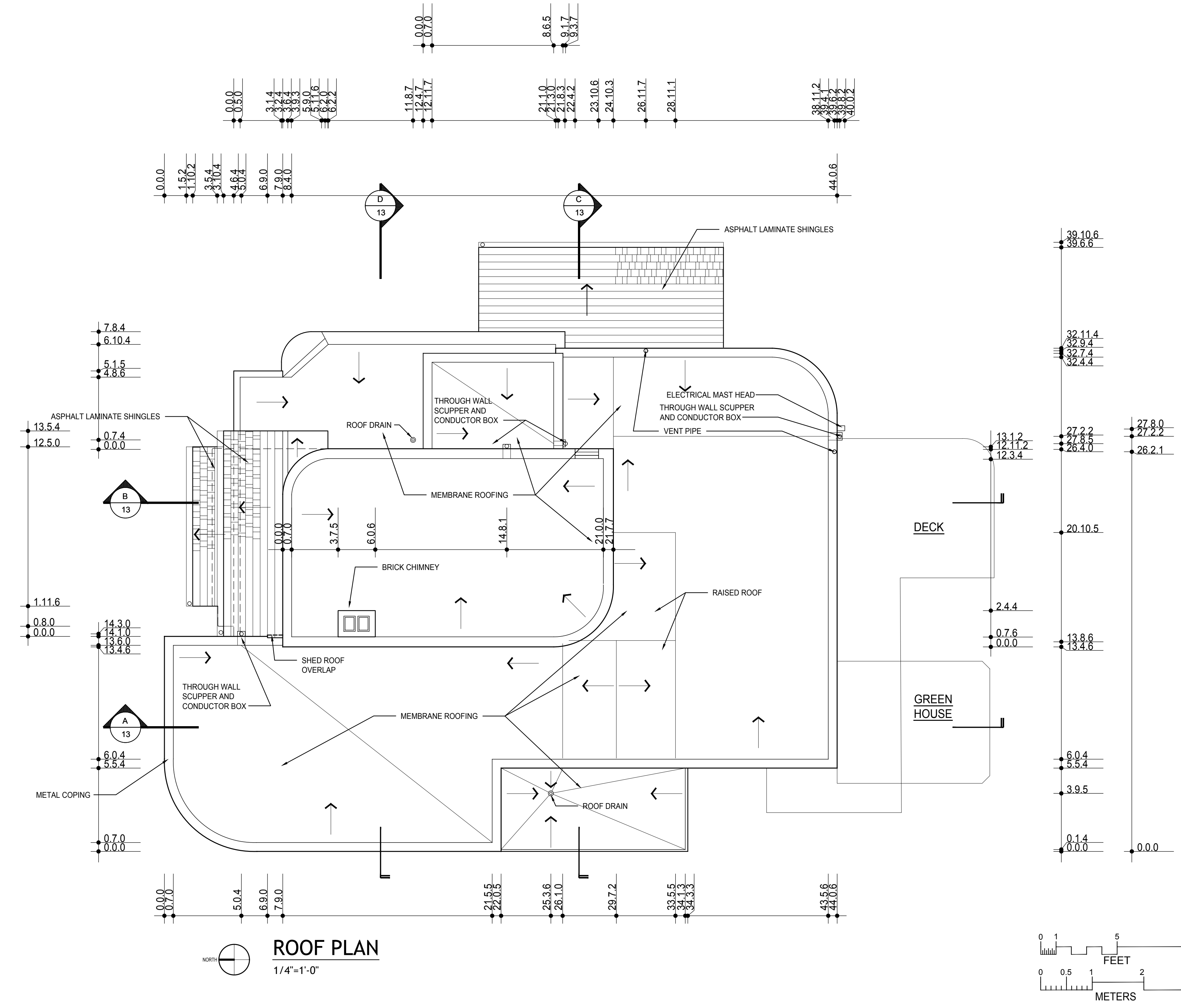

ROOF PLAN
1/4"=1'-0"

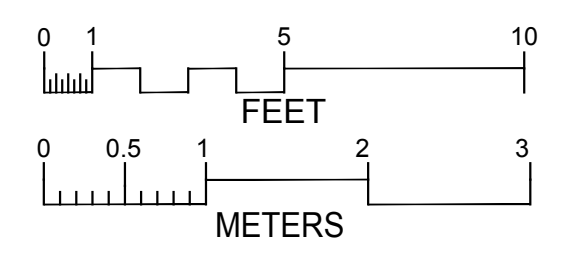

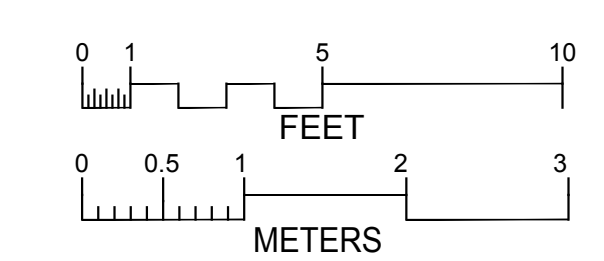
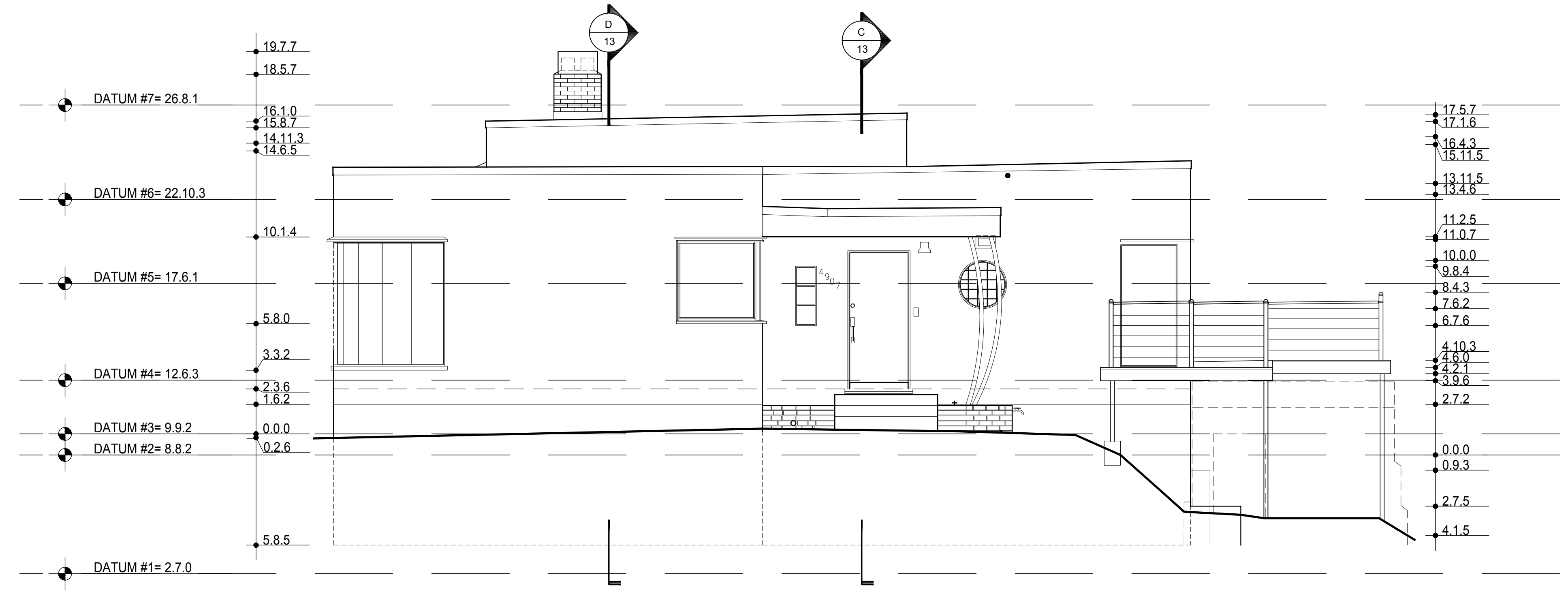
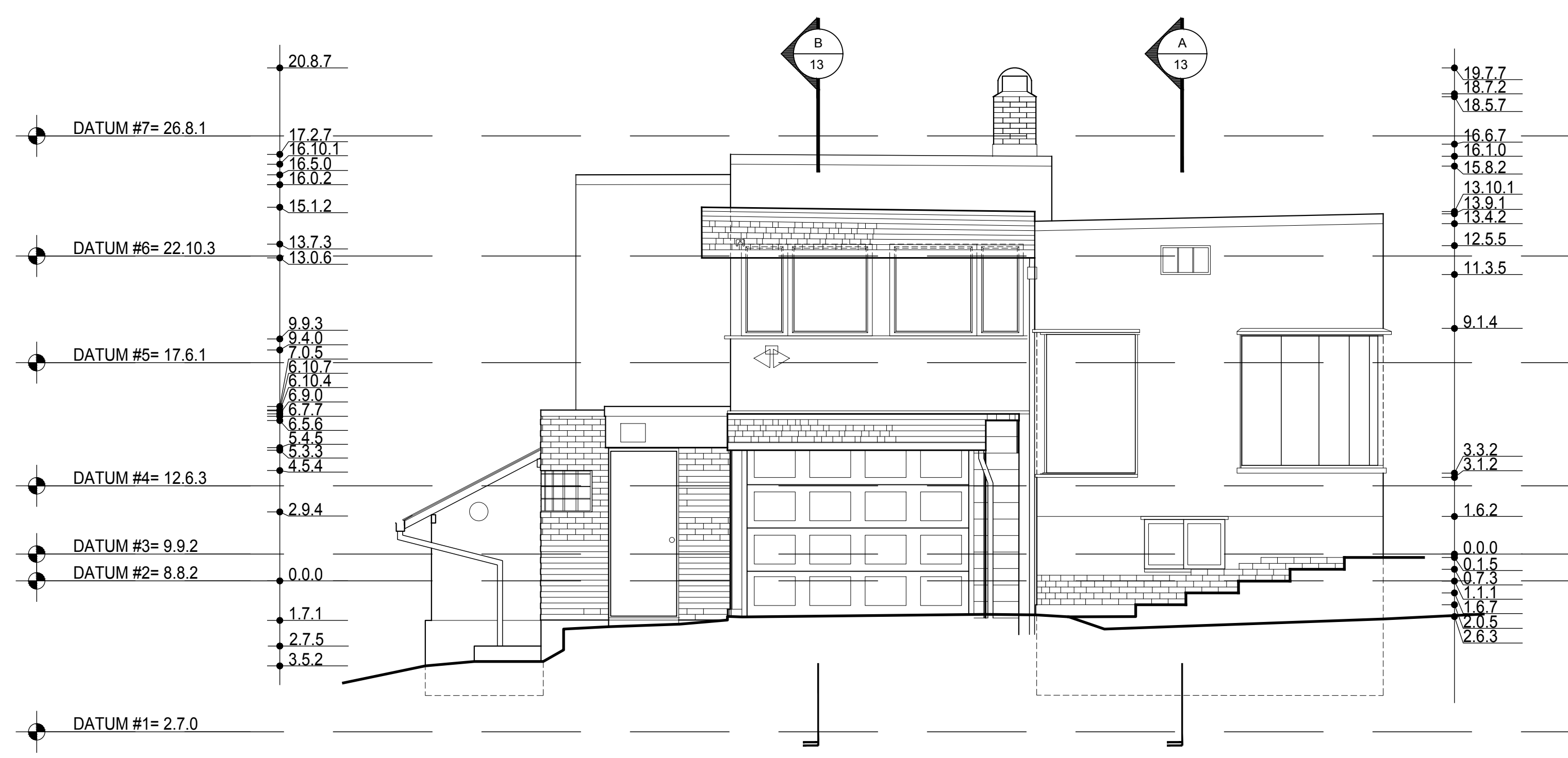
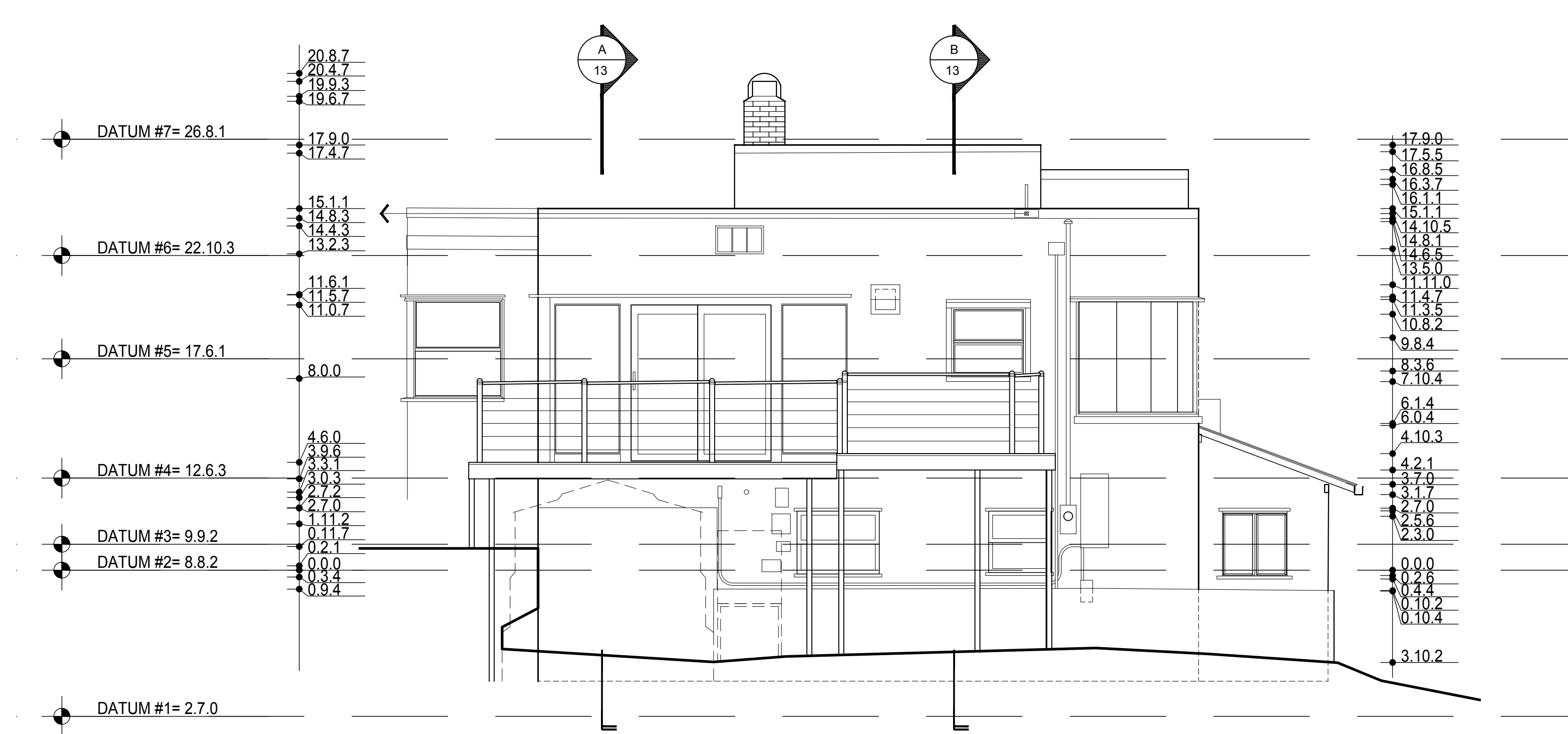
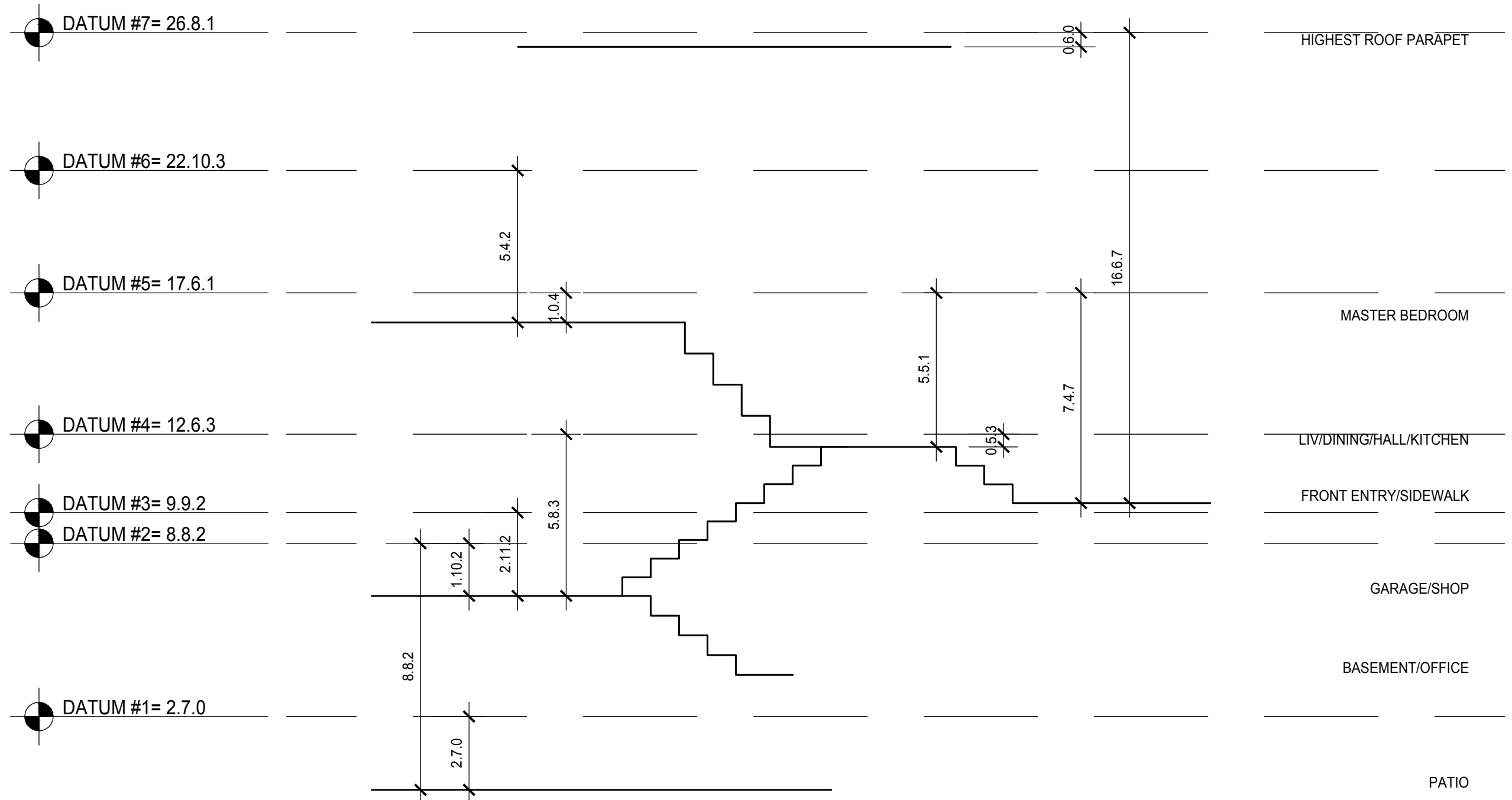



RICHAVEN
ARCHITECTURE &
PRESERVATION
9000 23RD AVE NW
SEATTLE, WA 98117
206.909.9866
WWW.RICHAVEN.COM

PIERCE COUNTY PLANNING AND PUBLIC WORKS
CONTRACT SC-107913 ON-CALL CULTURAL RESOURCE
ASSESSMENT
WORK ASSIGNMENT NO. 5: PO-187513 - HOUSE OF TOMORROW
AS PART OF THE CLARKS CREEK PROPERTY ACQUISITION

REV # DATE NAME
01 03/31/2023 DRAFT SUBMITTAL

HOUSE OF TOMORROW
HABS LEVEL 1 DOCUMENTATION
4907 66TH AVENUE EAST, PUWALLUP, WA 98371

BUILDING SECTIONS
DAB/BDR
SCALE: 1/4" = 1'-0"

SHEET NUMBER:
13

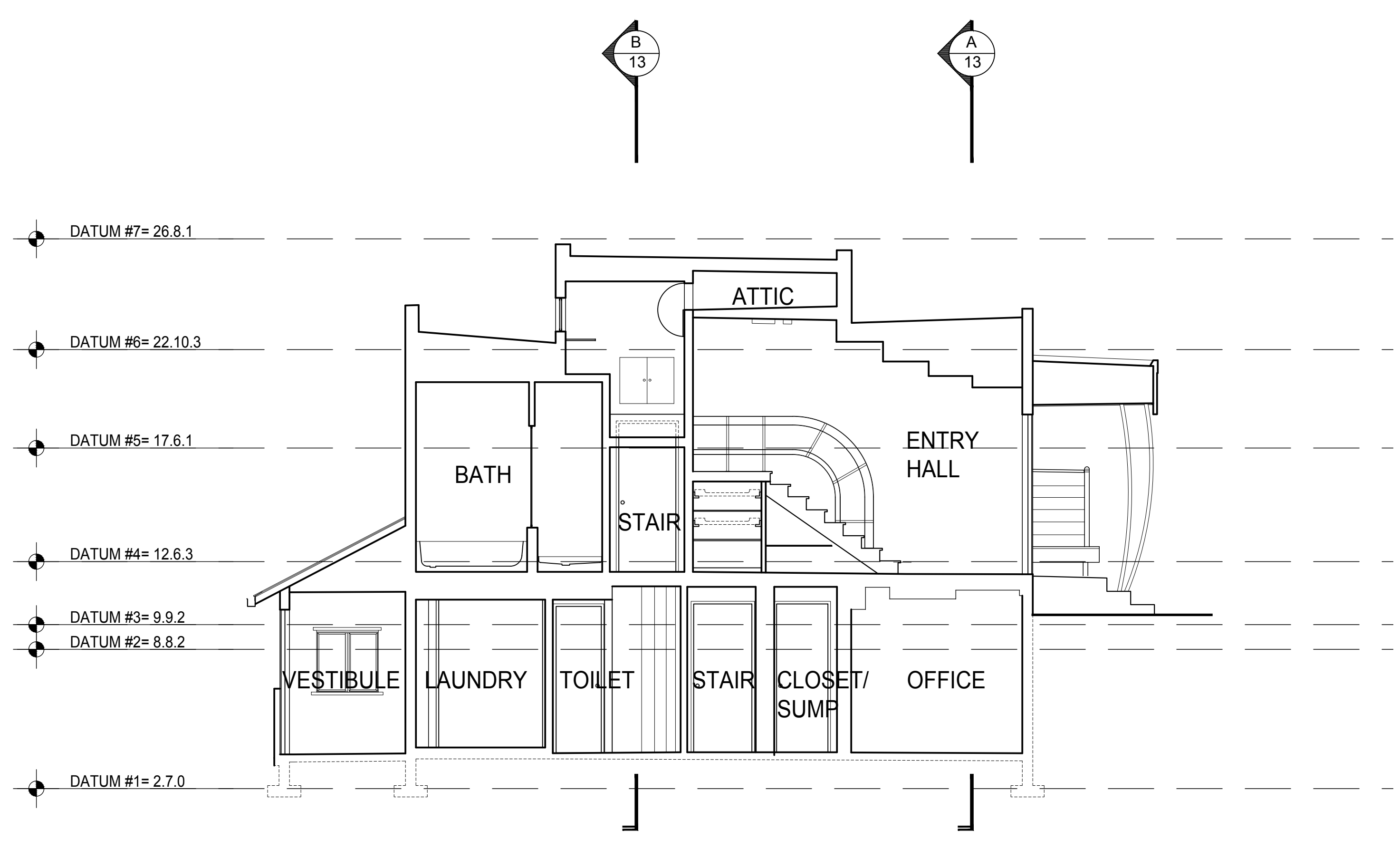

C BUILDING SECTION
1/4" = 1'-0"

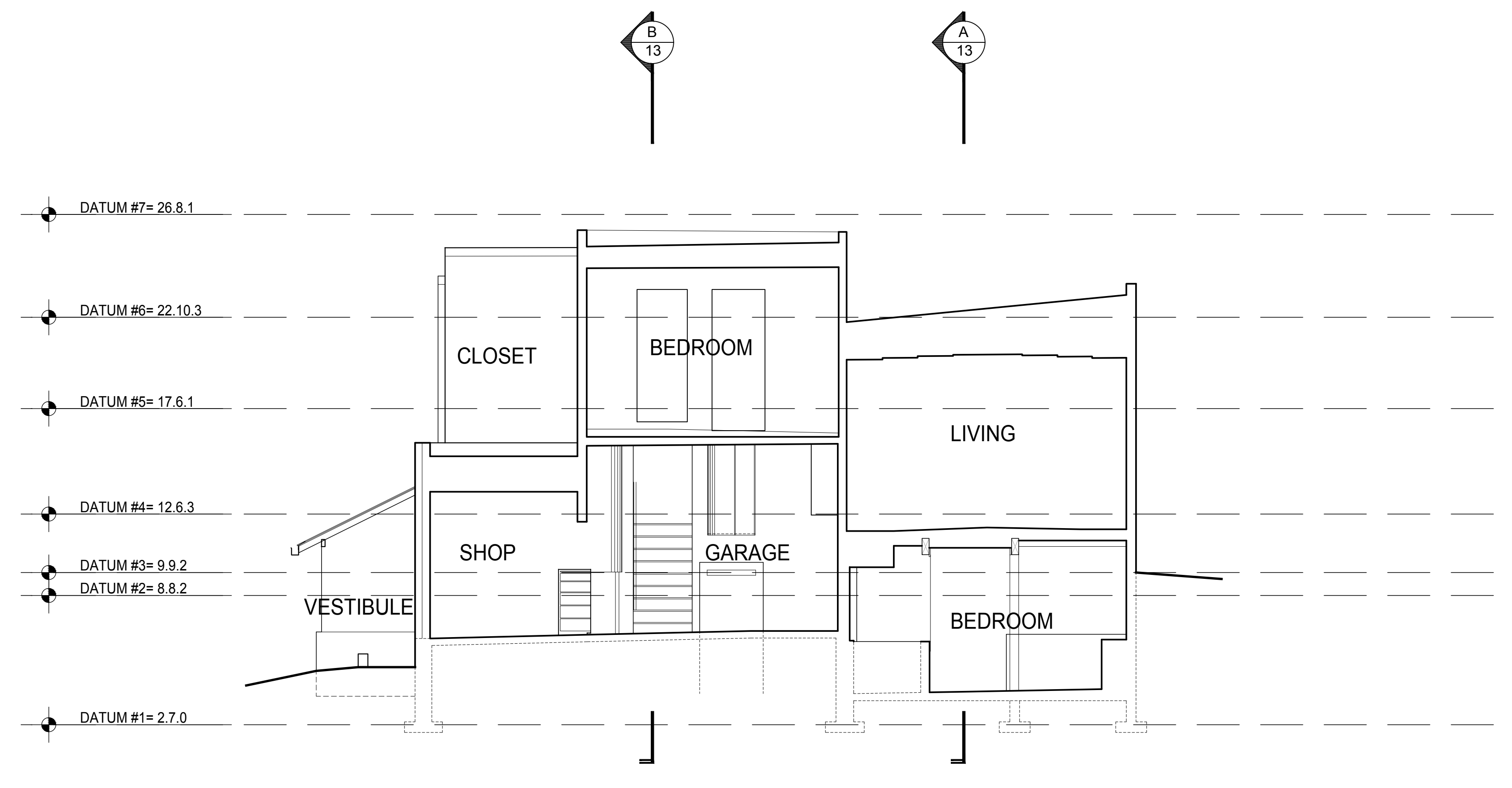

D BUILDING SECTION
1/4" = 1'-0"

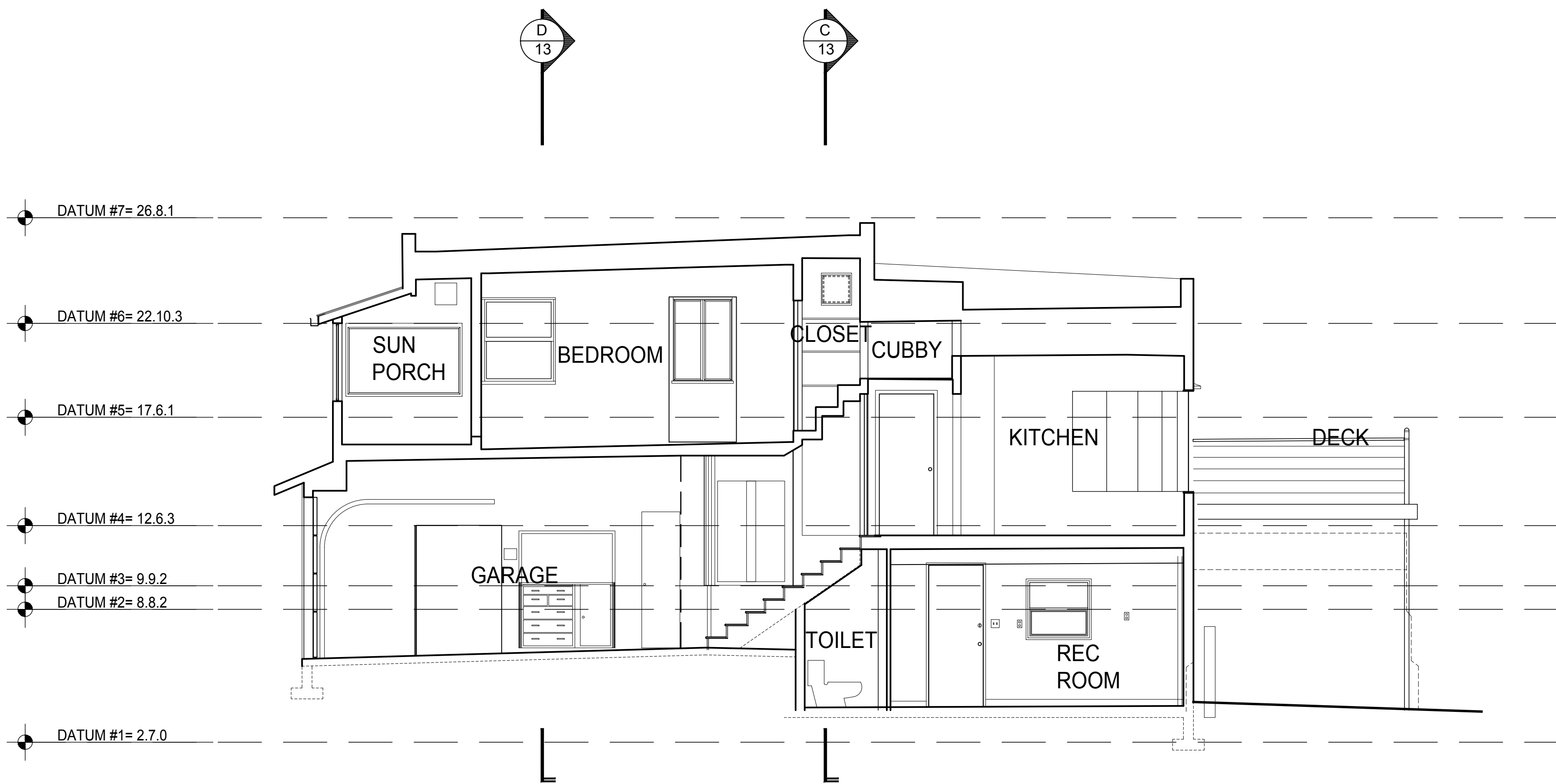

B BUILDING SECTION
1/4" = 1'-0"

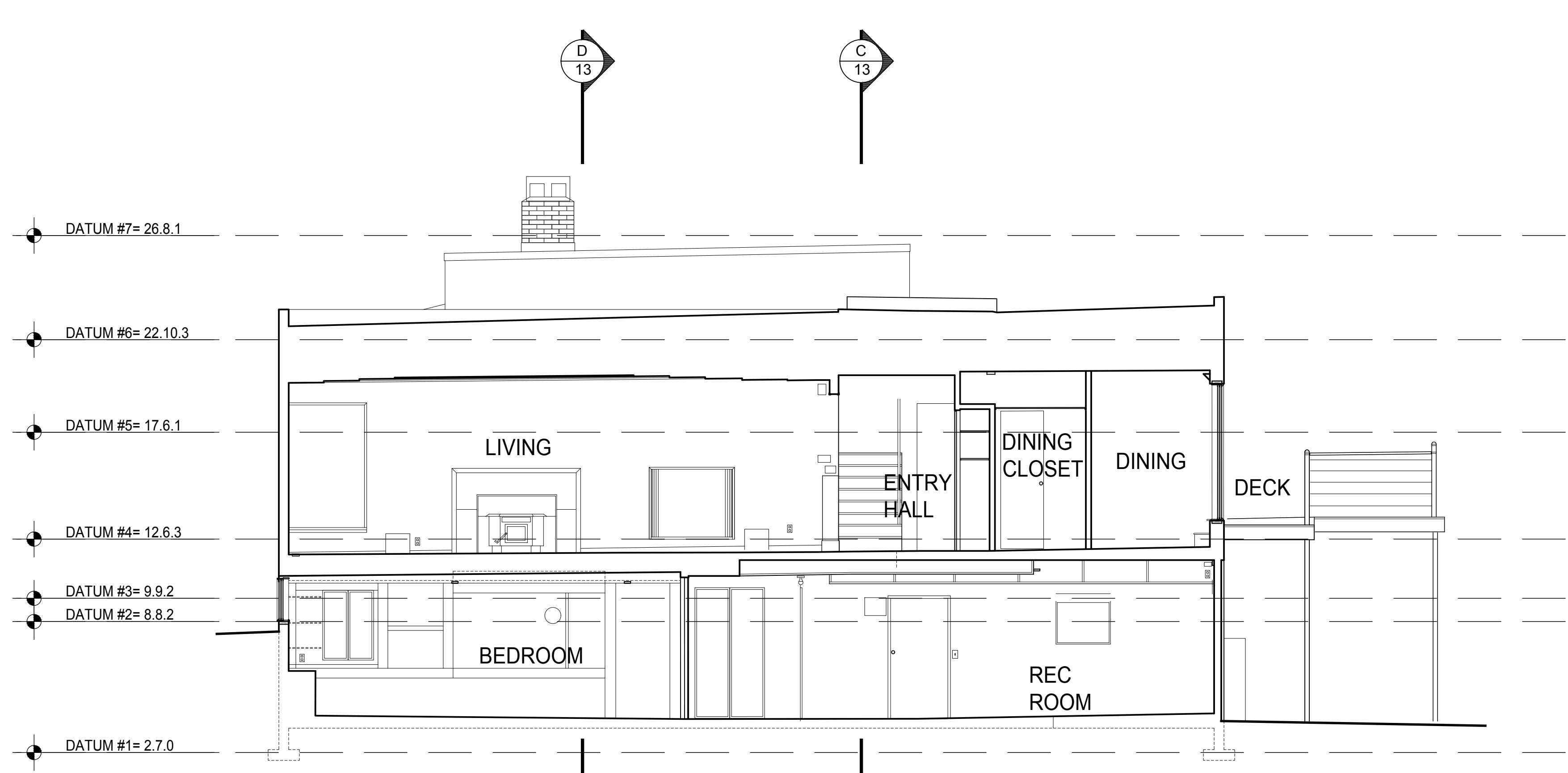

A BUILDING SECTION
1/4" = 1'-0"

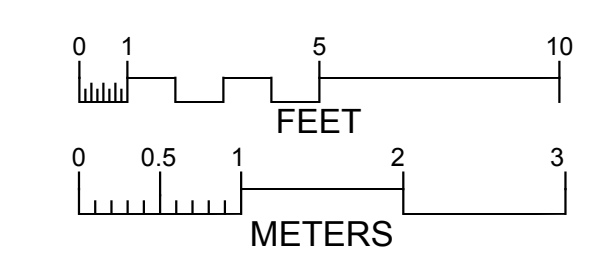



RICHAVEN
ARCHITECTURE &
PRESERVATION
9000 23RD AVE NW
SEATTLE, WA 98117
206.909.9866
WWW.RICHAVEN.COM

PIERCE COUNTY PLANNING AND PUBLIC WORKS
CONTRACT SC-107913 ON-CALL CULTURAL RESOURCE ASSESSMENT
WORK ASSIGNMENT NO. 5; PO-187513 - HOUSE OF TOMORROW
AS PART OF THE CLARKS CREEK PROPERTY ACQUISITION

REV.# DATE NAME
01 03/31/2023 DRAFT SUBMITTAL

HOUSE OF TOMORROW
HABS LEVEL 1 DOCUMENTATION
4907 66TH AVENUE EAST, PUYALLUP, WA 98371

INTERIOR ELEVATIONS:
MAIN FLOOR
SCALE: 3/8" = 1'-0"
DAB/BDP

SHEET NUMBER:
14

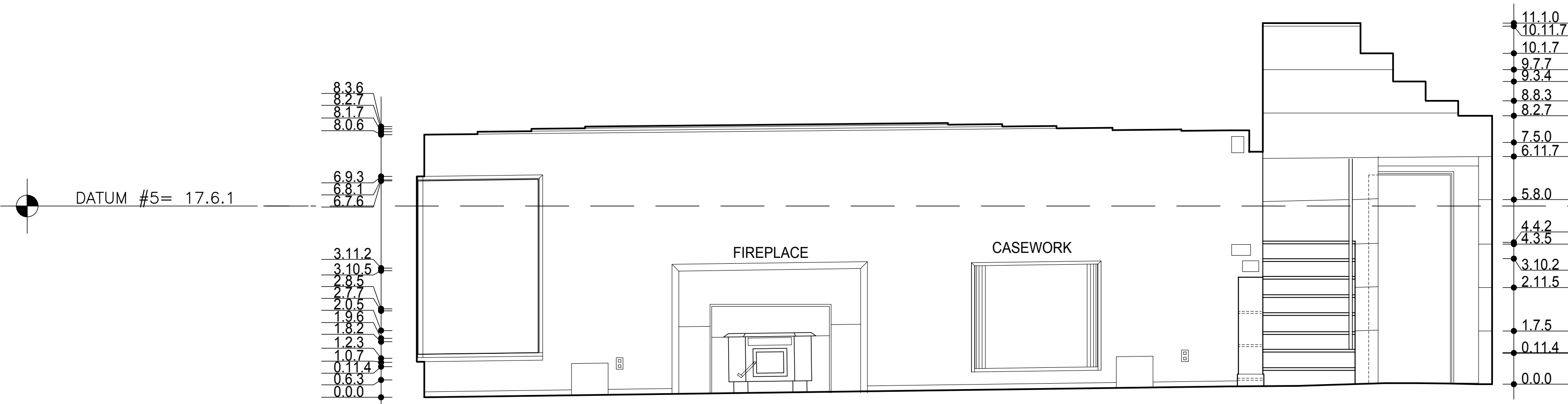

01 LIVING ROOM - ENTRY / HALL (EAST)
3/8" = 1'-0"

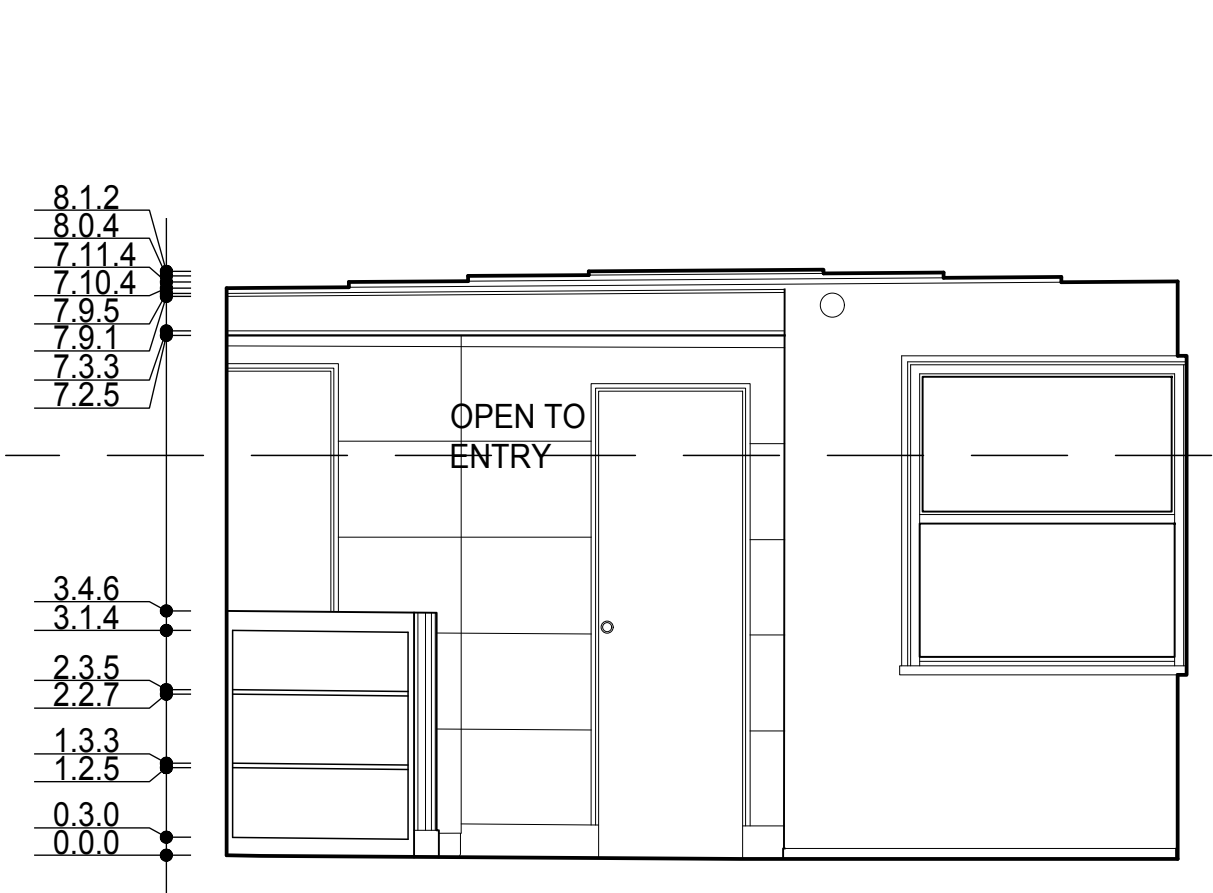

02 LIVING ROOM (SOUTH)
3/8" = 1'-0"

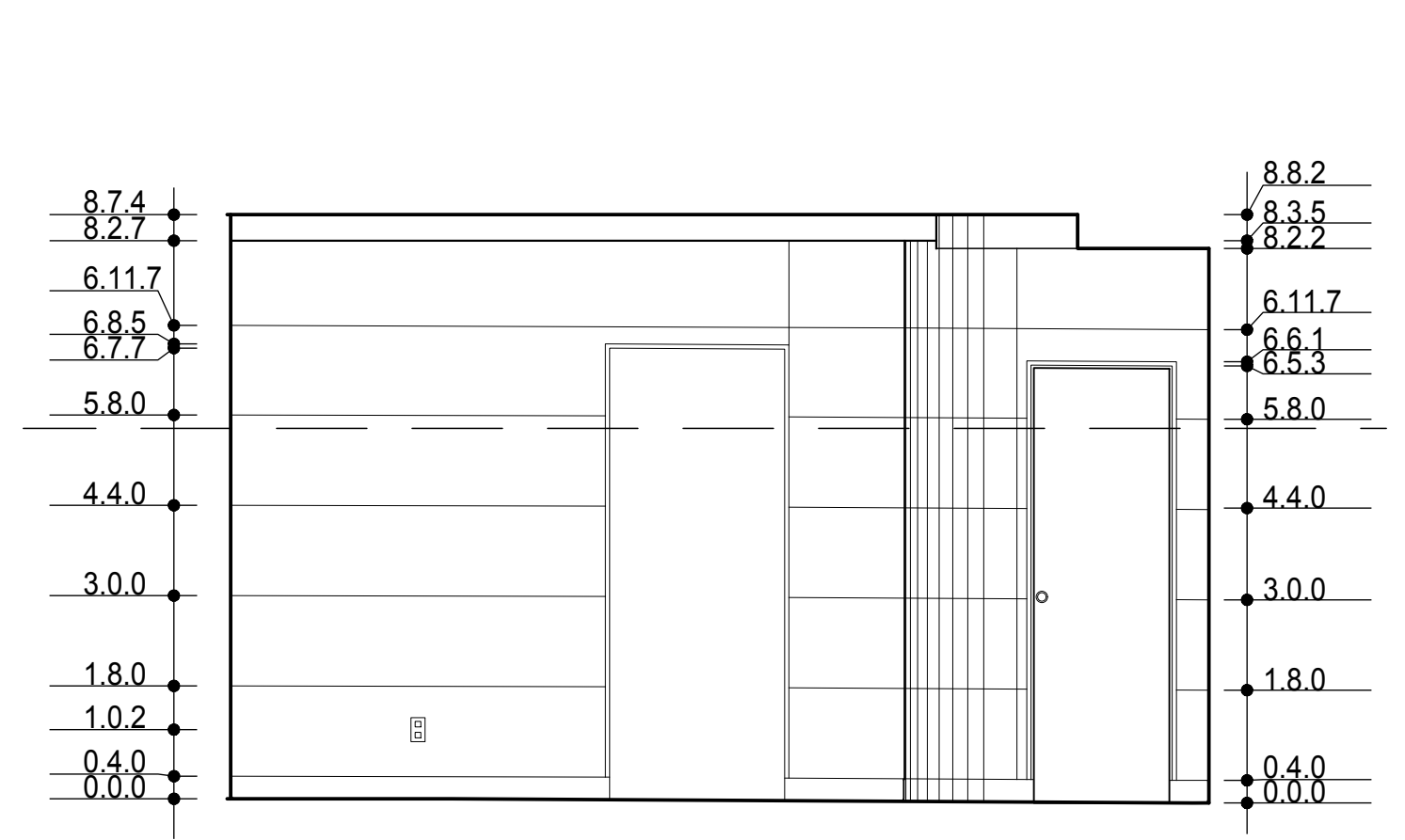

03 ENTRY / HALL (SOUTH)
3/8" = 1'-0"

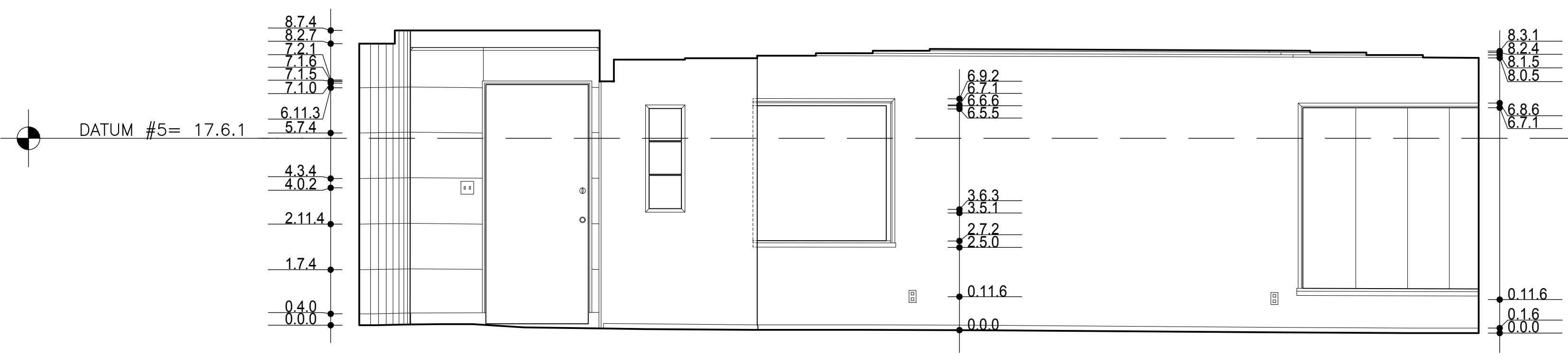

04 ENTRY / HALL (WEST) LIVING ROOM (WEST)
3/8" = 1'-0"

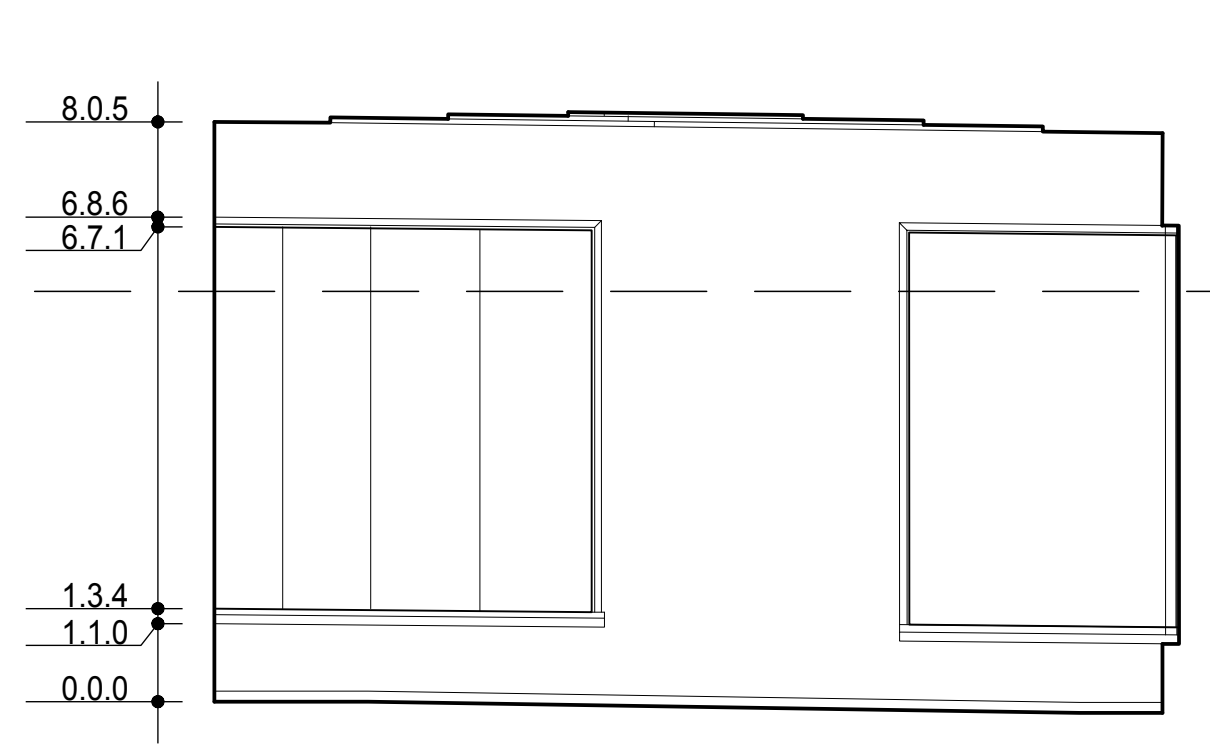

05 LIVING ROOM (NORTH)
3/8" = 1'-0"

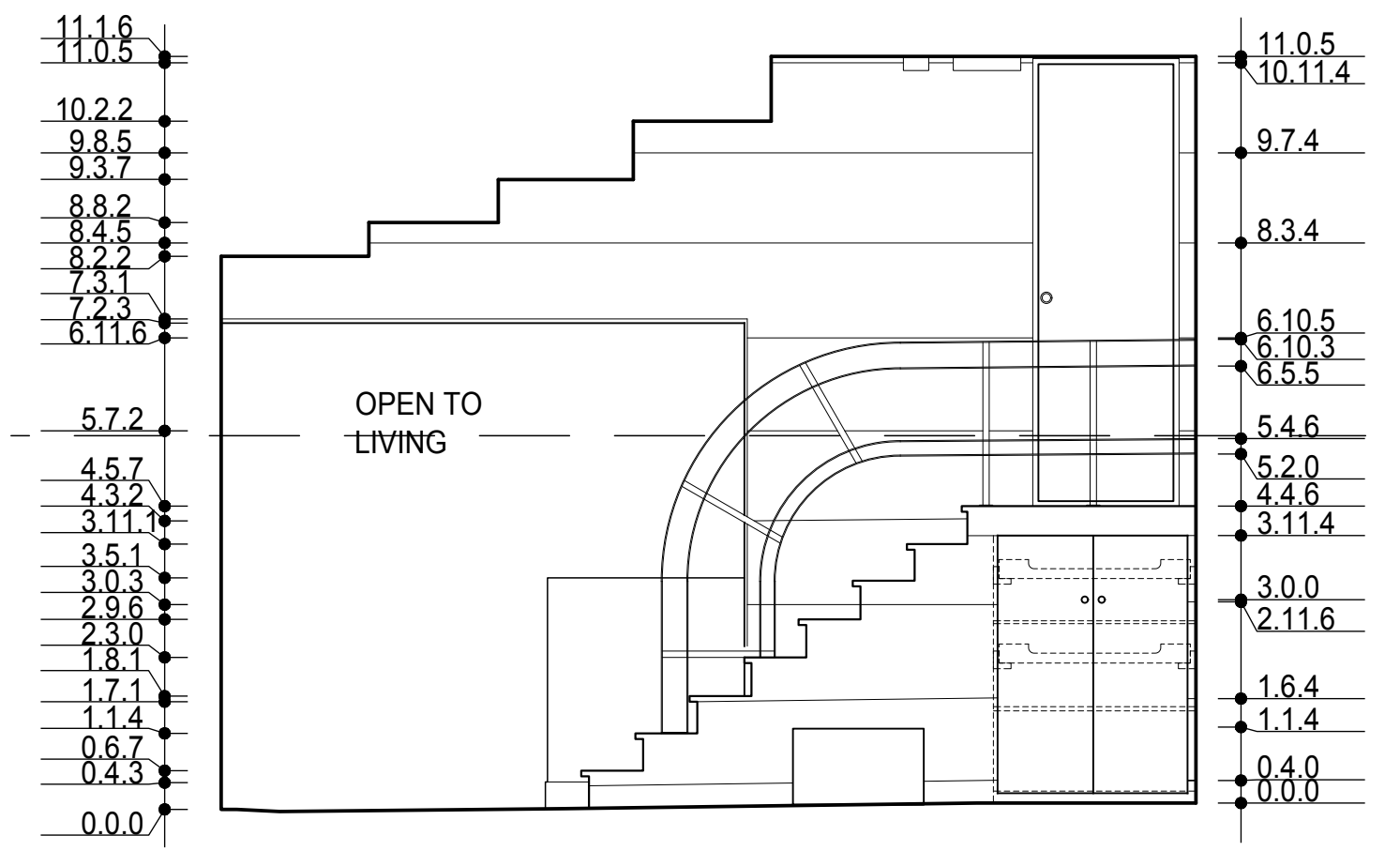

06 ENTRY / HALL (NORTH)
3/8" = 1'-0"

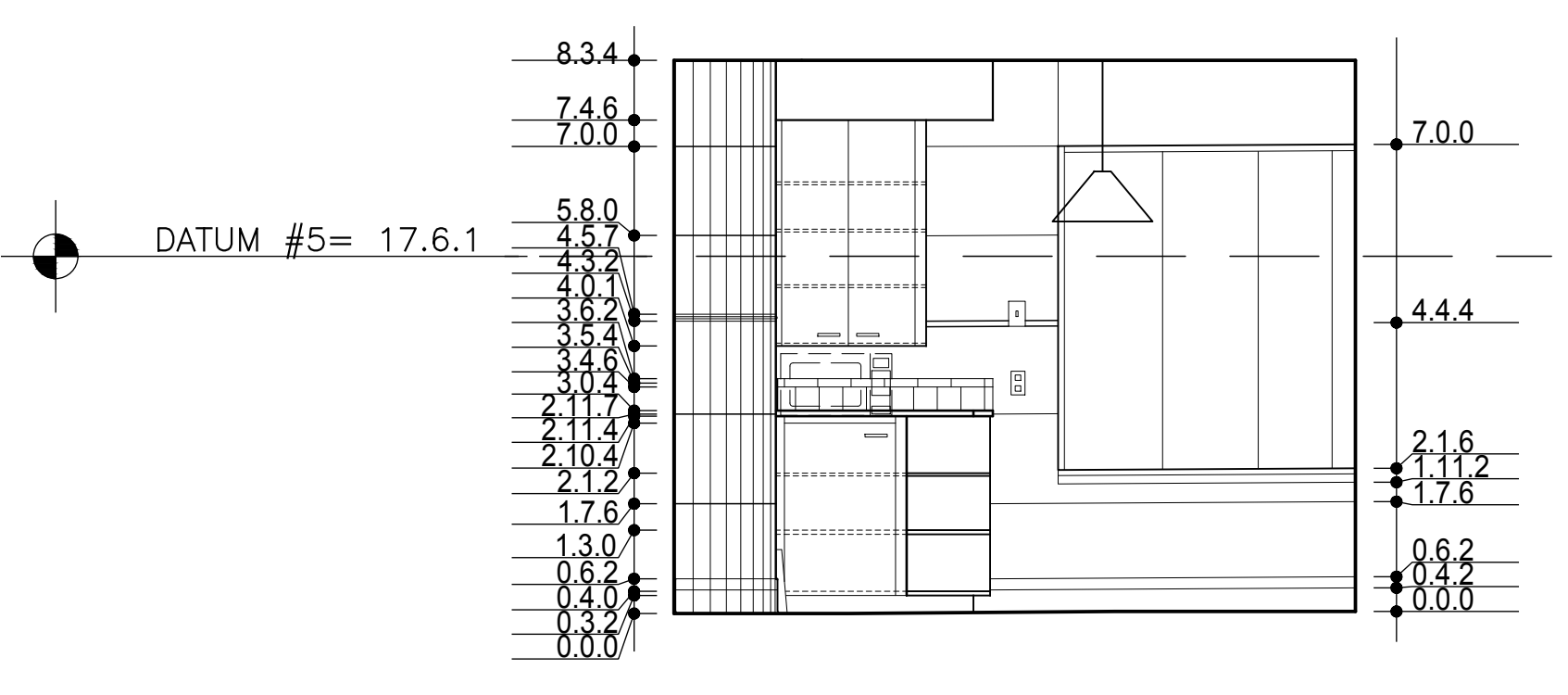

07 KITCHEN (EAST)
3/8" = 1'-0"

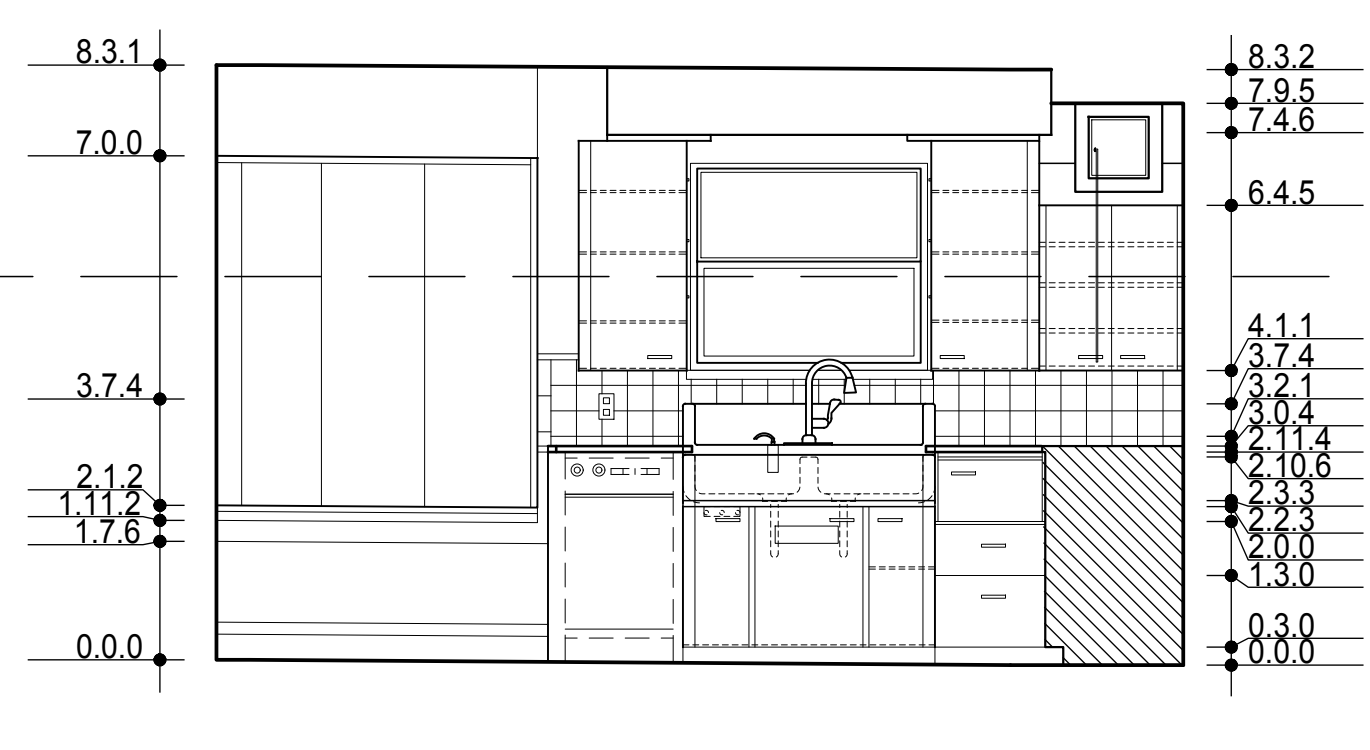

08 KITCHEN (SOUTH)
3/8" = 1'-0"

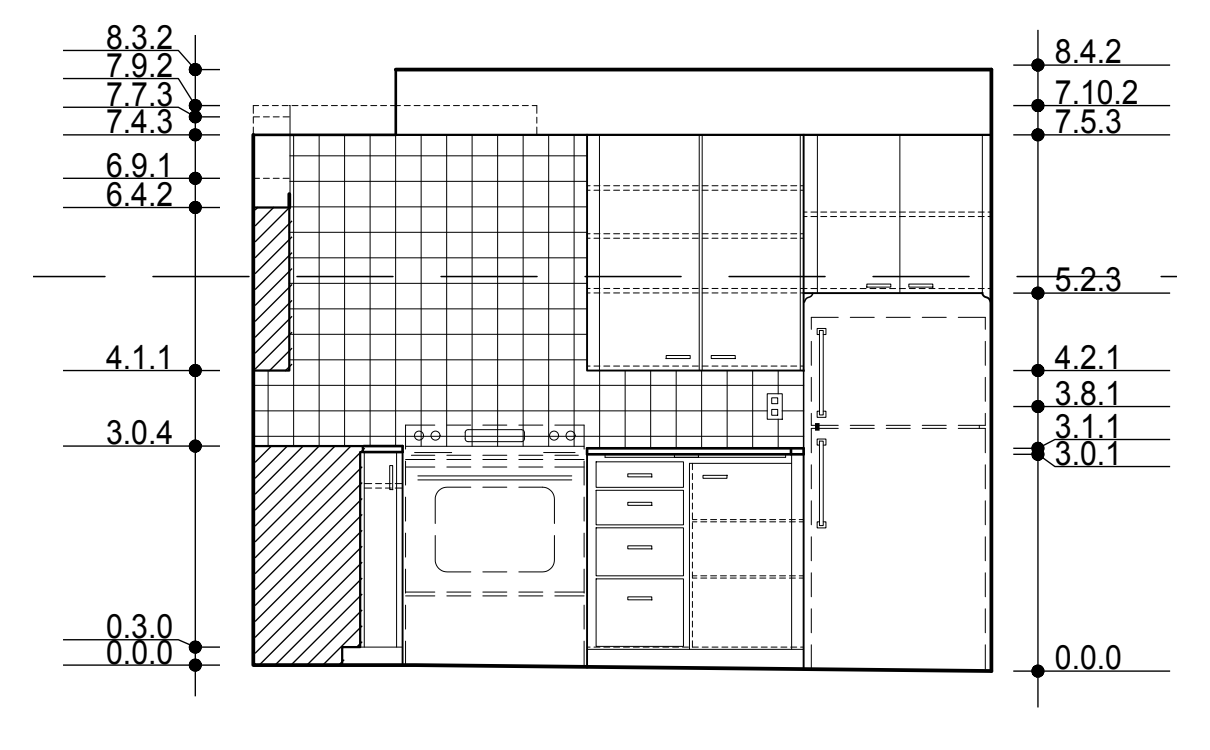

09 KITCHEN (WEST)
3/8" = 1'-0"

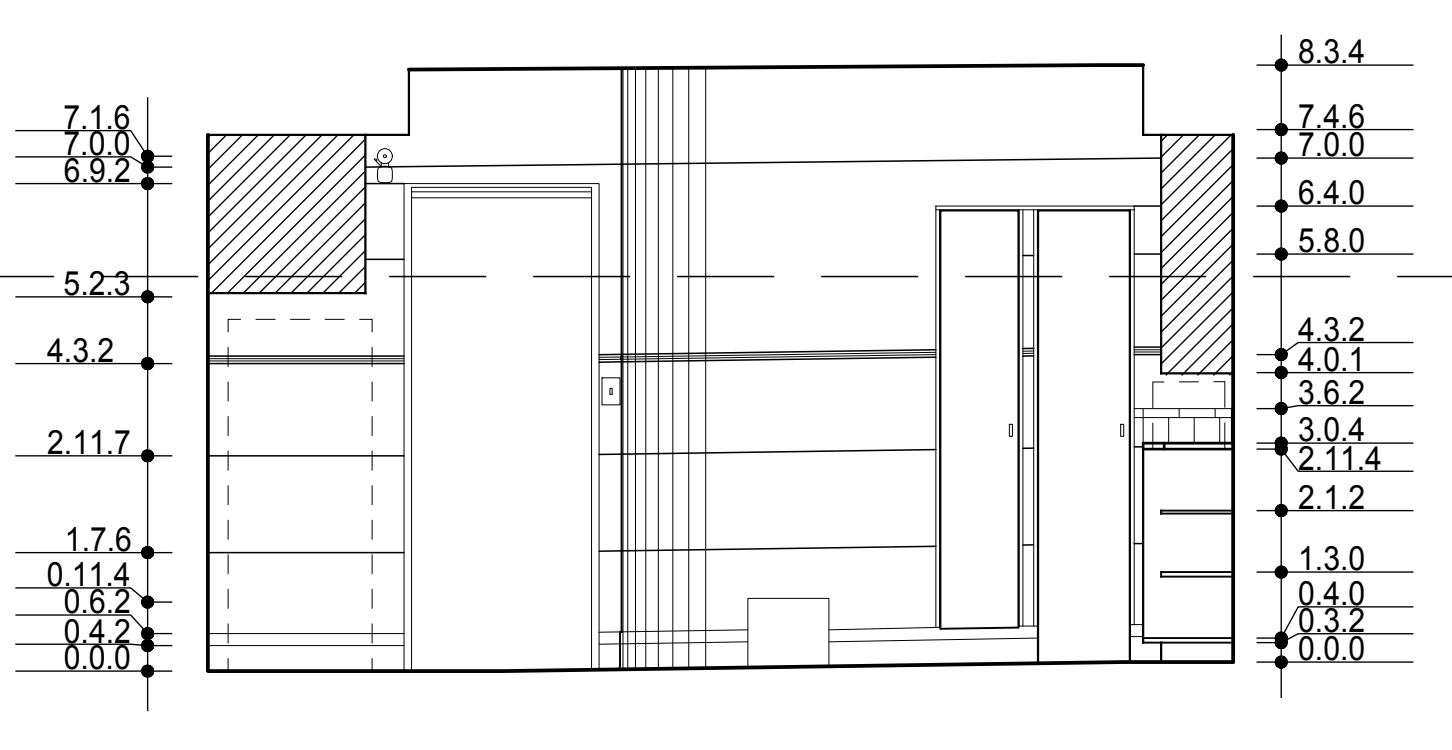

10 KITCHEN (NORTH)
3/8" = 1'-0"

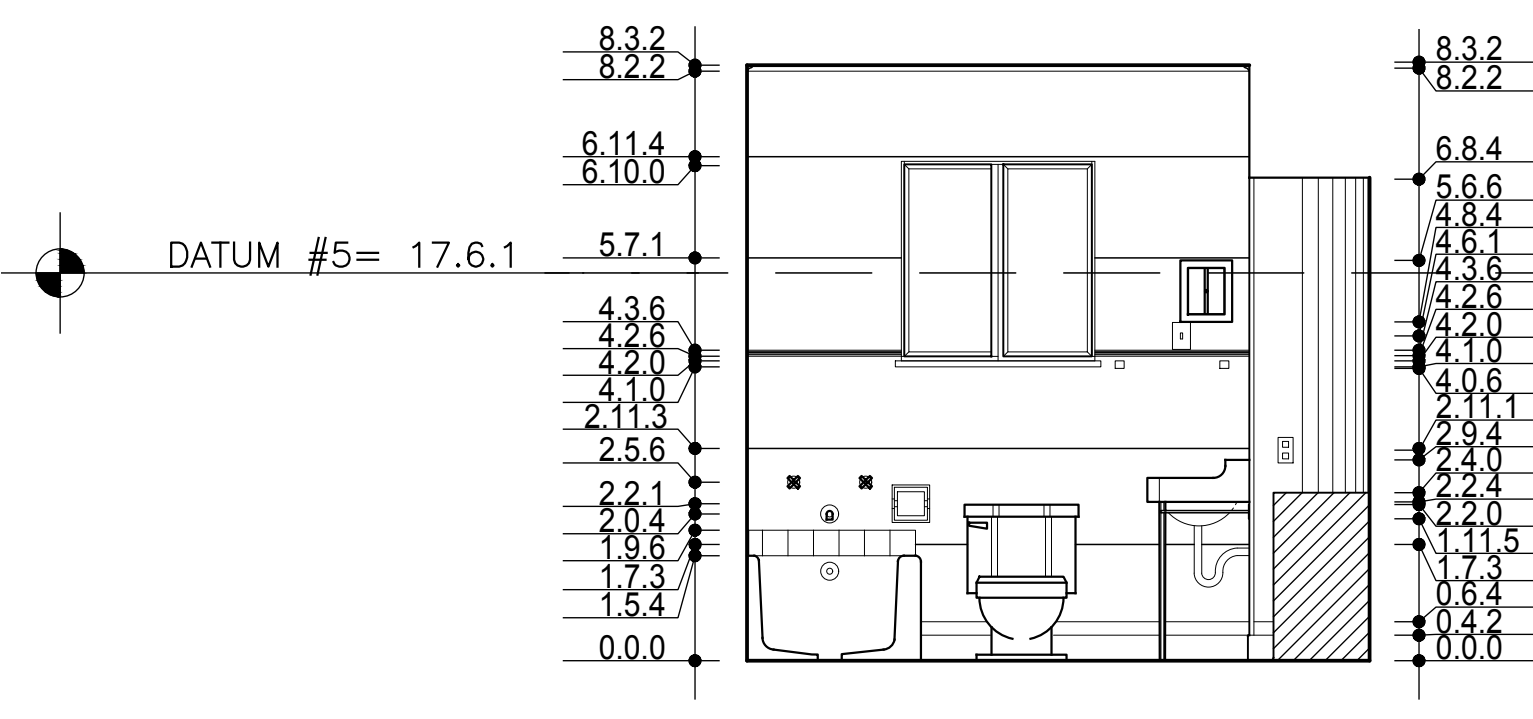

11 BATHROOM (EAST)
3/8" = 1'-0"

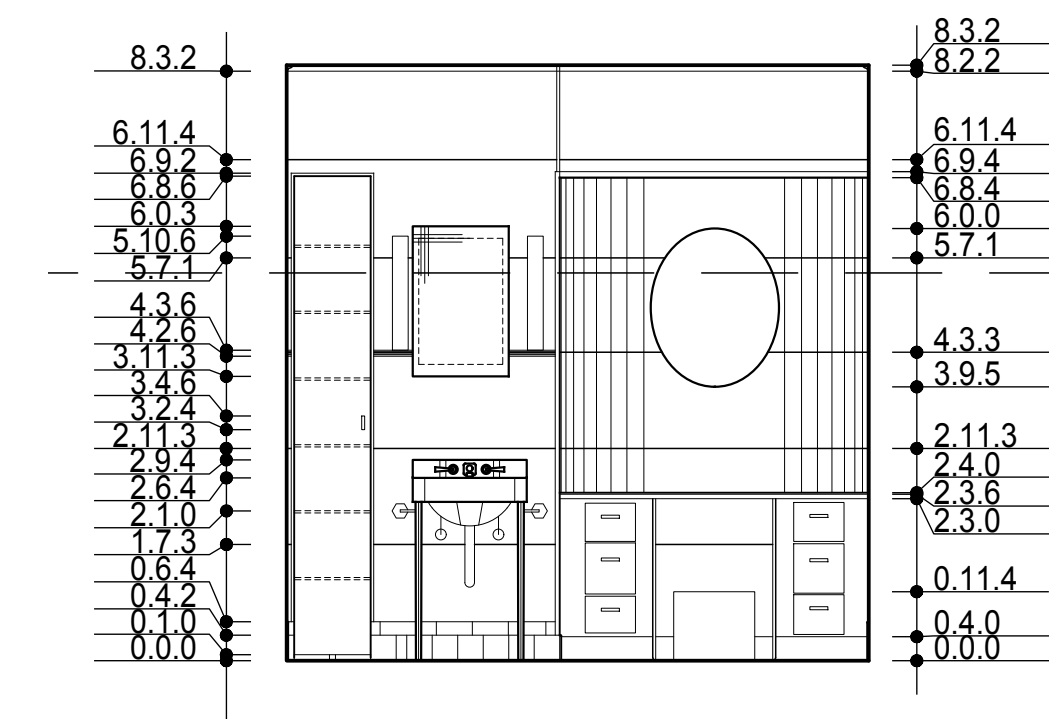

12 BATHROOM (SOUTH)
3/8" = 1'-0"

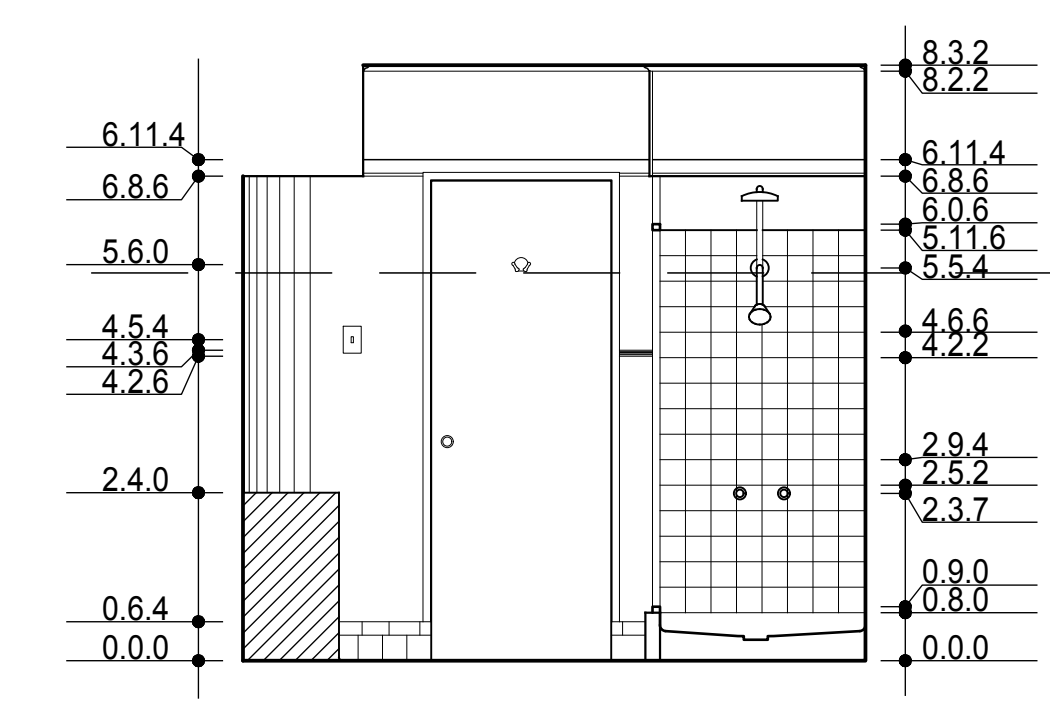

13 BATHROOM (WEST)
3/8" = 1'-0"

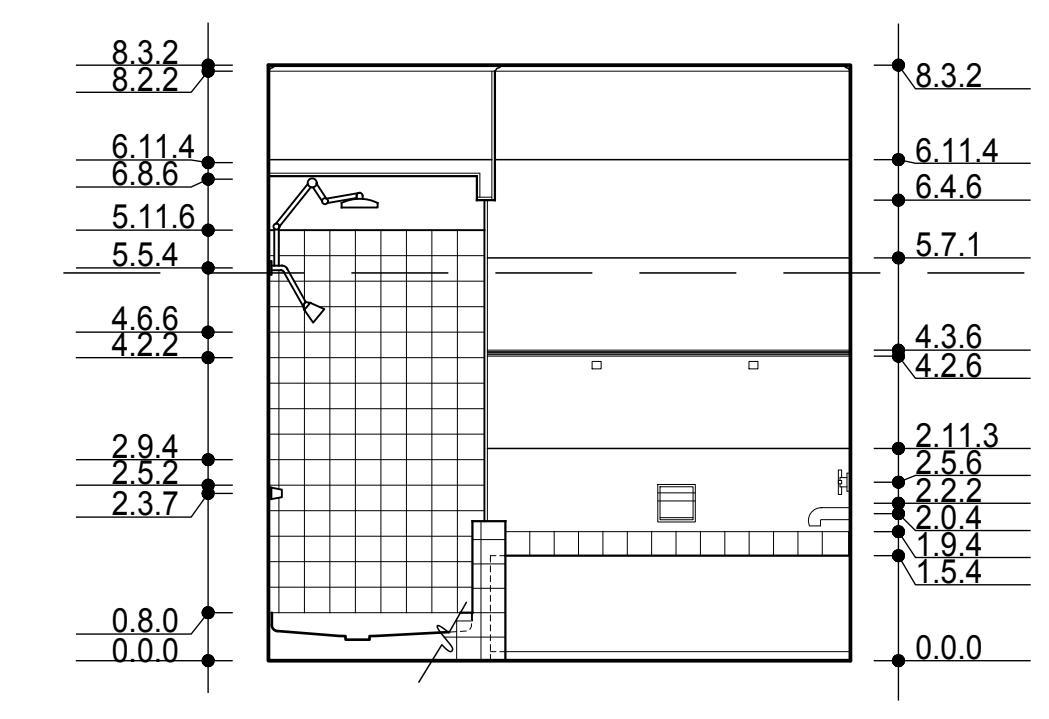

14 BATHROOM (NORTH)
3/8" = 1'-0"

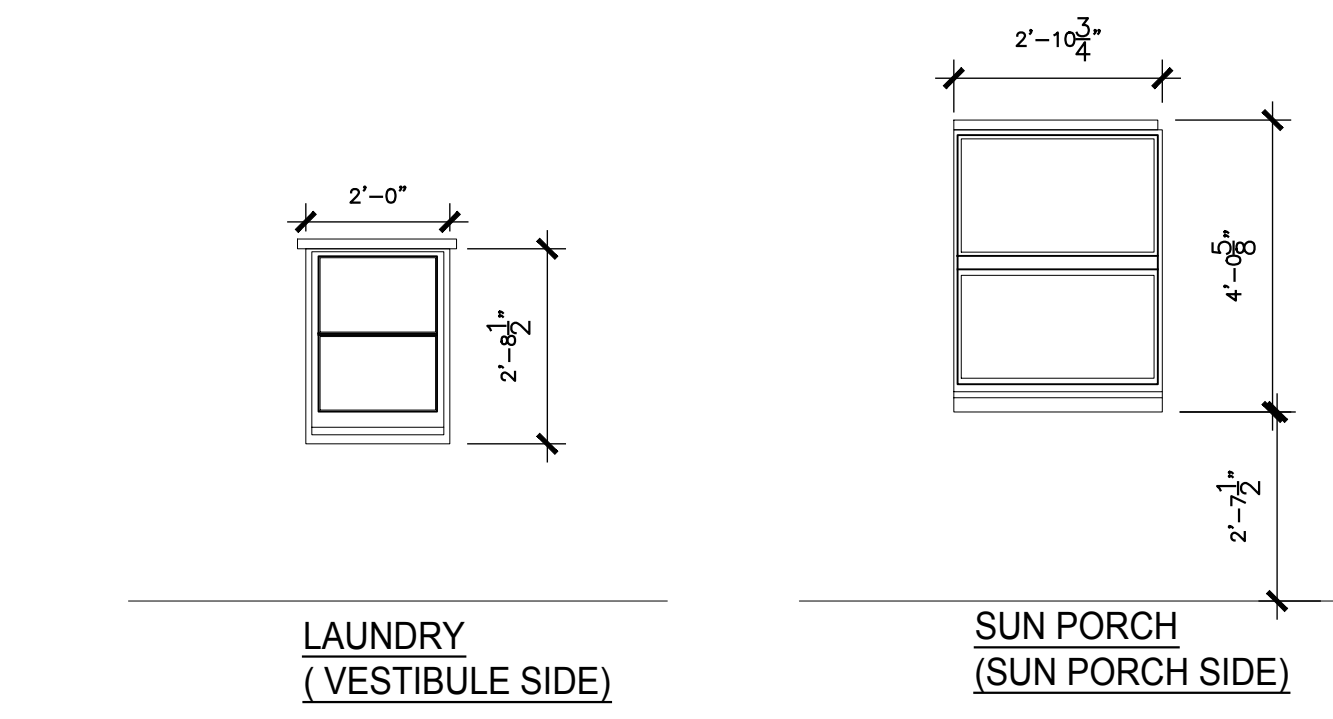

15 PATRIAL INTERIOR ELEVATIONS
3/8" = 1'-0"

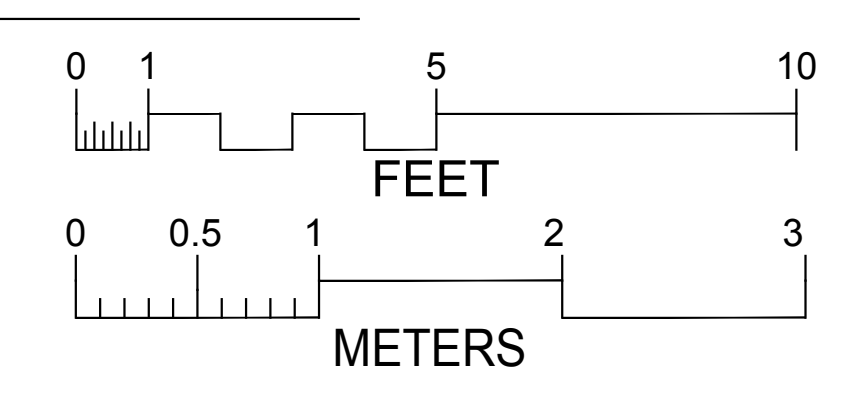

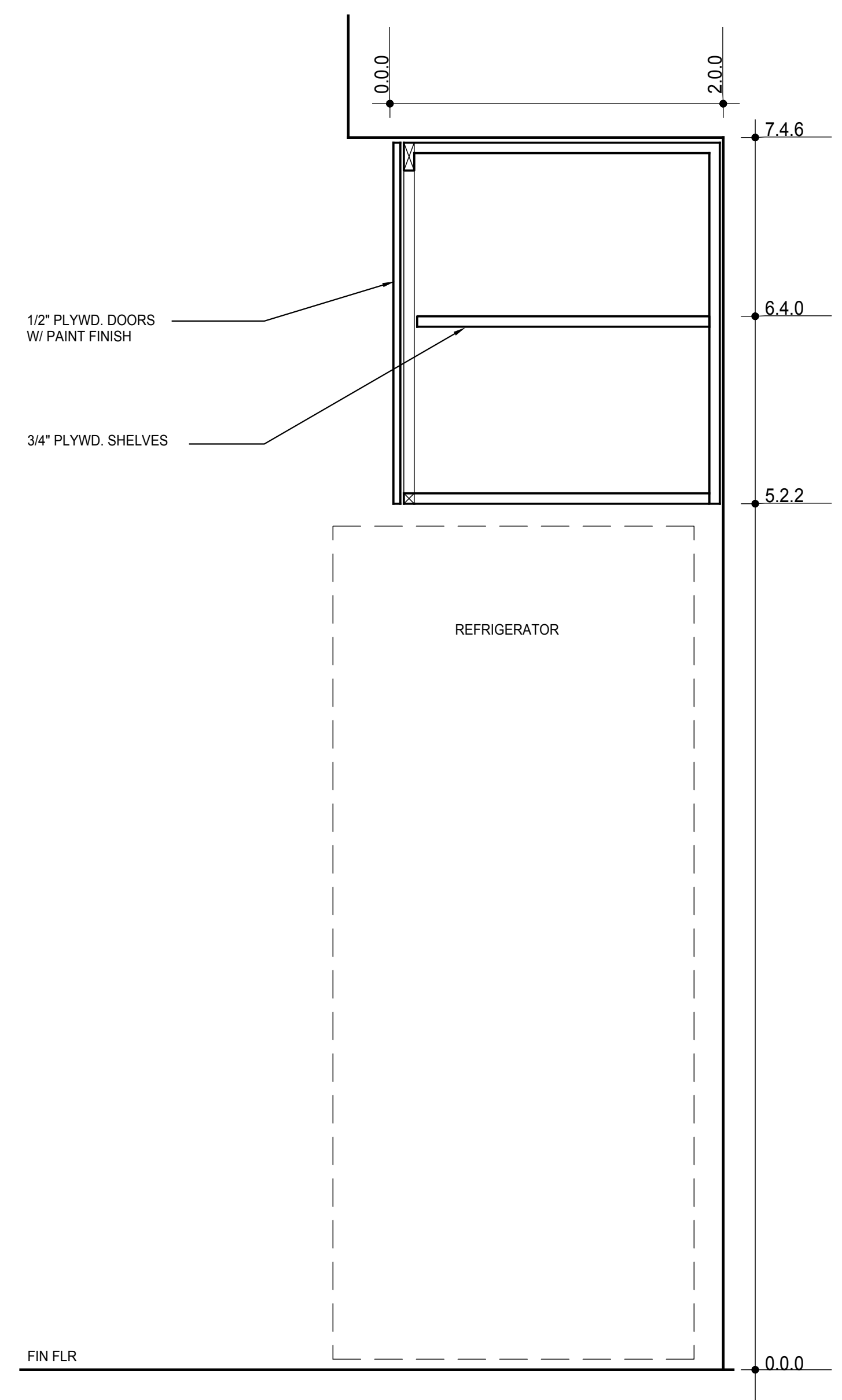
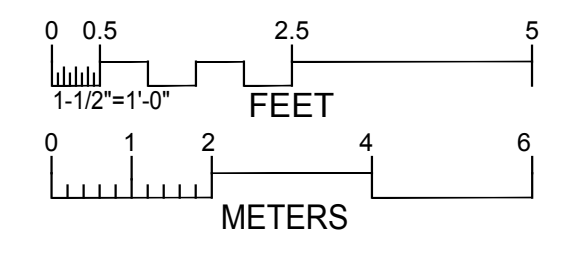

03 UPPER CABINET @ REFRIGERATOR
1-1/2" = 1'-0"

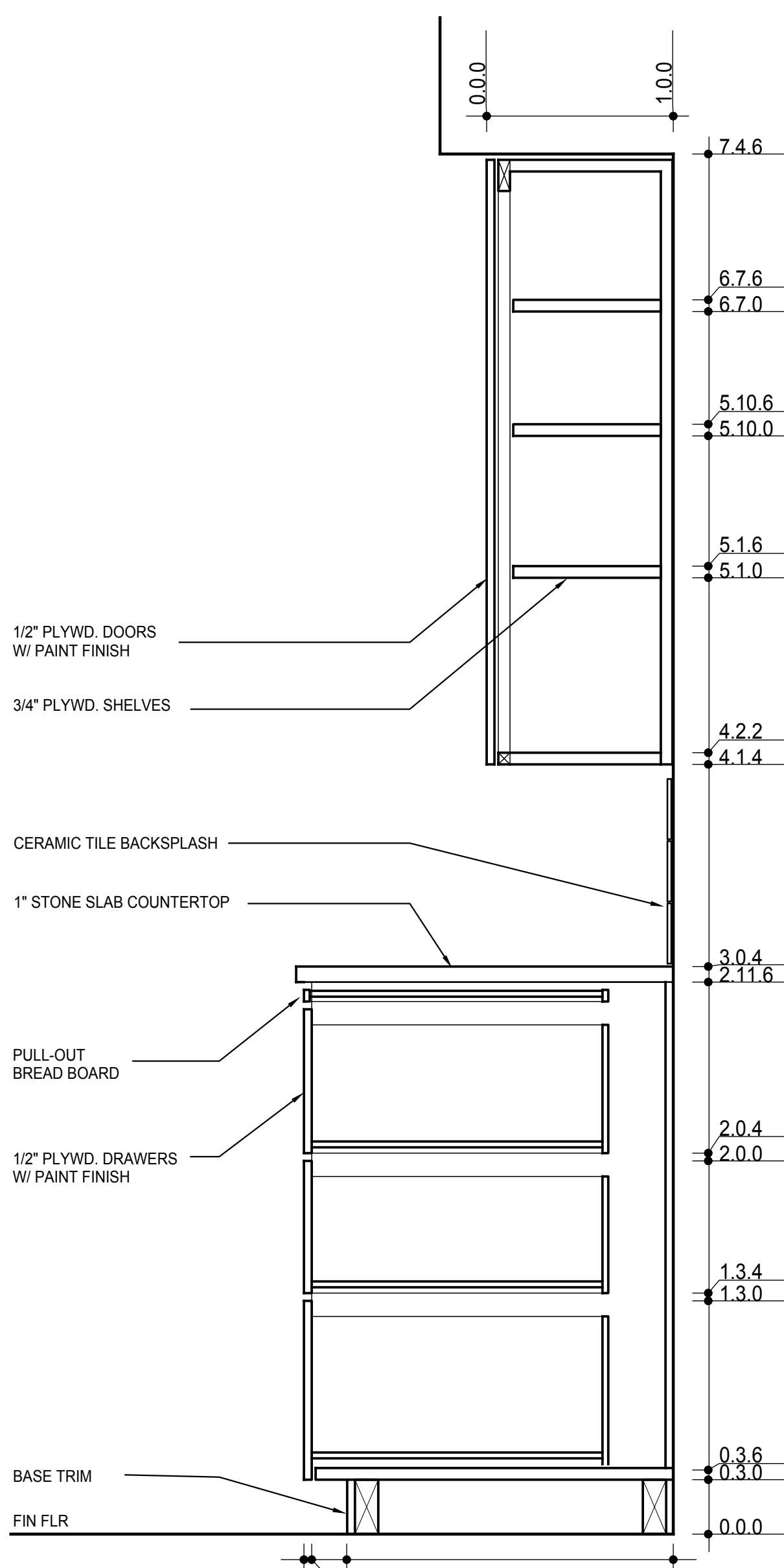

04a CAB. BETWEEN STOVE & FRIDGE (L)
1-1/2" = 1'-0"

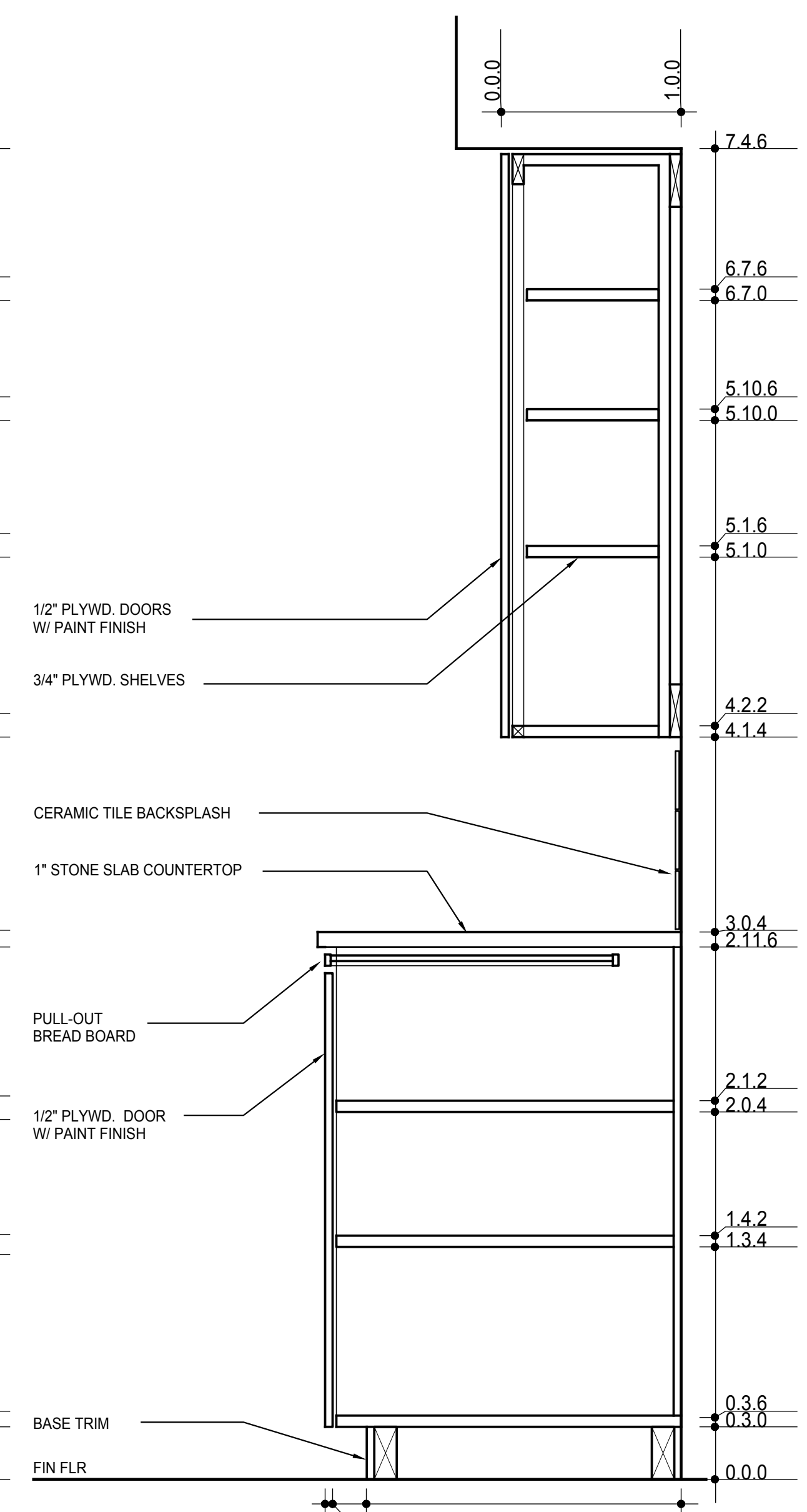

04b CAB. BETWEEN STOVE & FRIDGE (R)
1-1/2" = 1'-0"

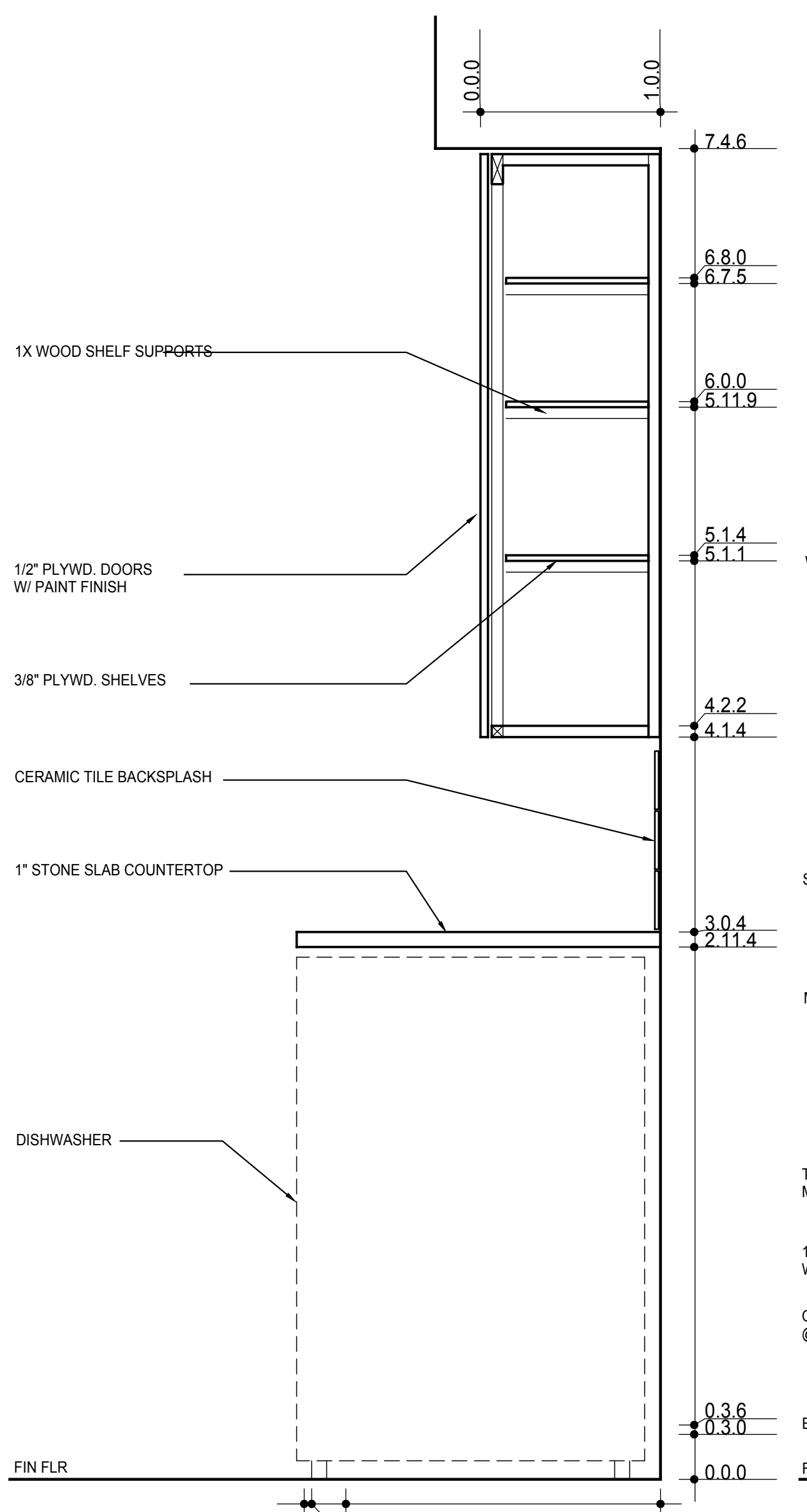

05 CAB LEFT SIDE OF SINK
1-1/2" = 1'-0"

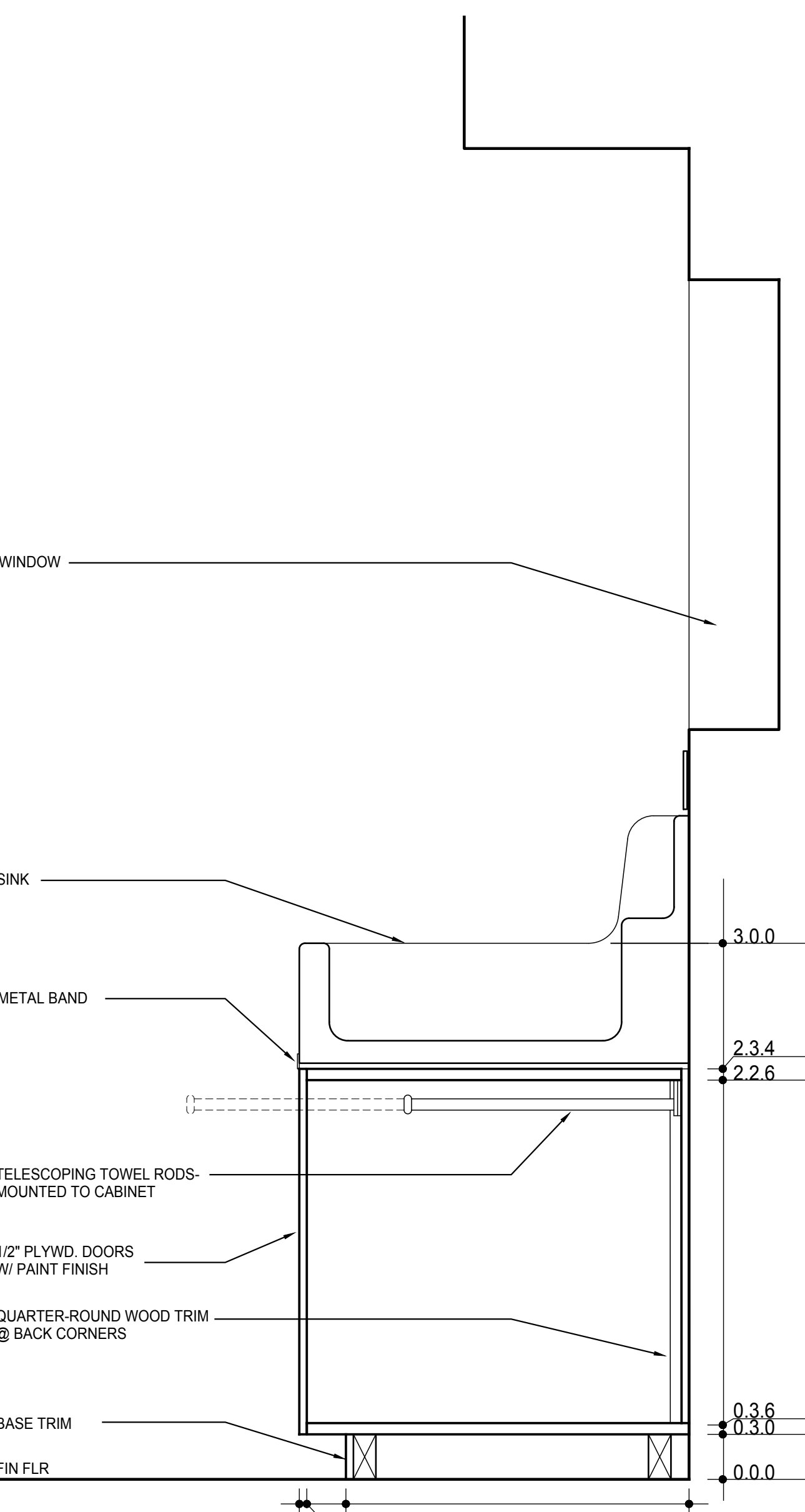

06a SINK CABINET (L - TOWEL BARS))
1-1/2" = 1'-0"

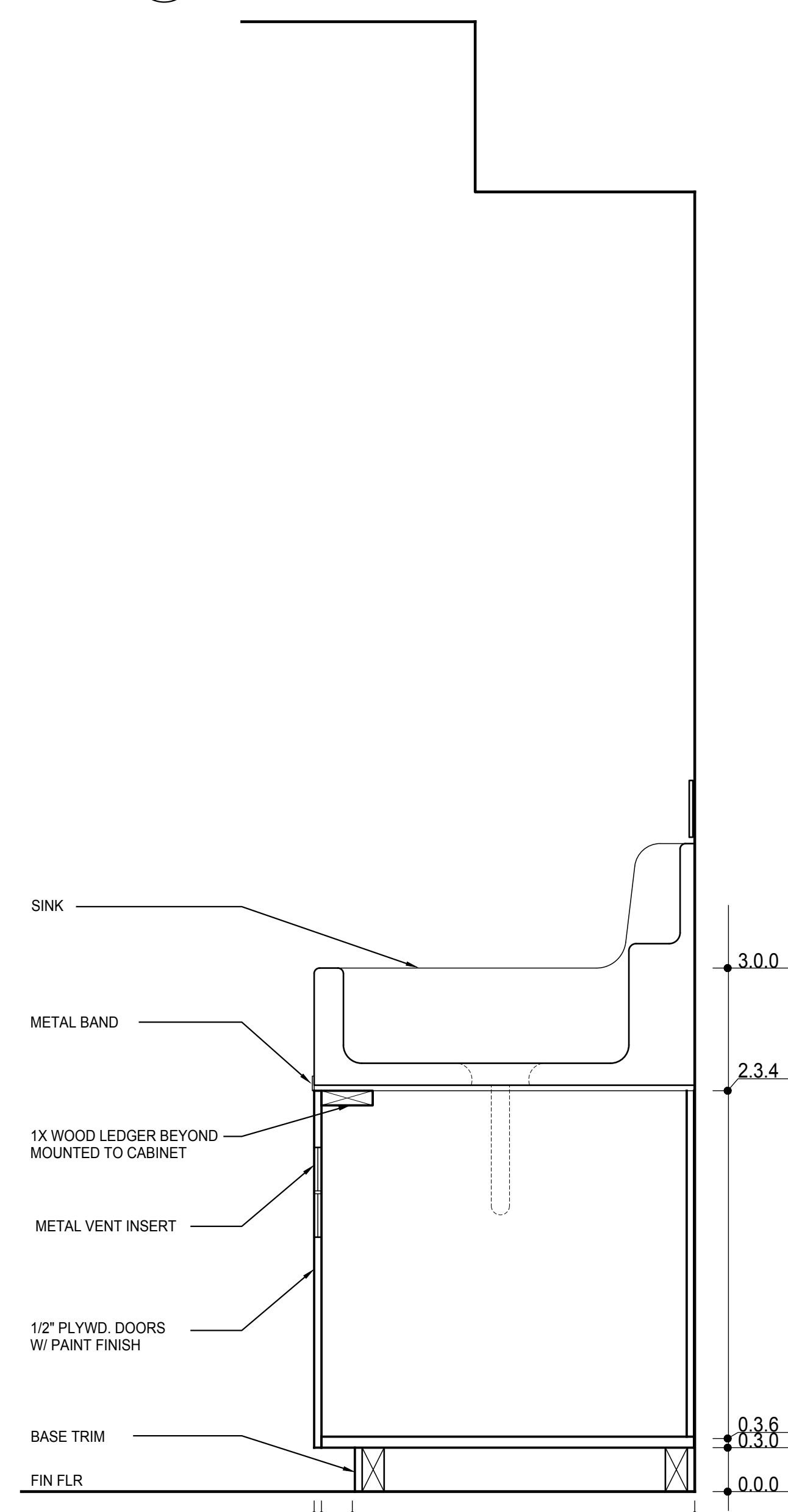

06b SINK CABINET (CENTER)
1-1/2" = 1'-0"

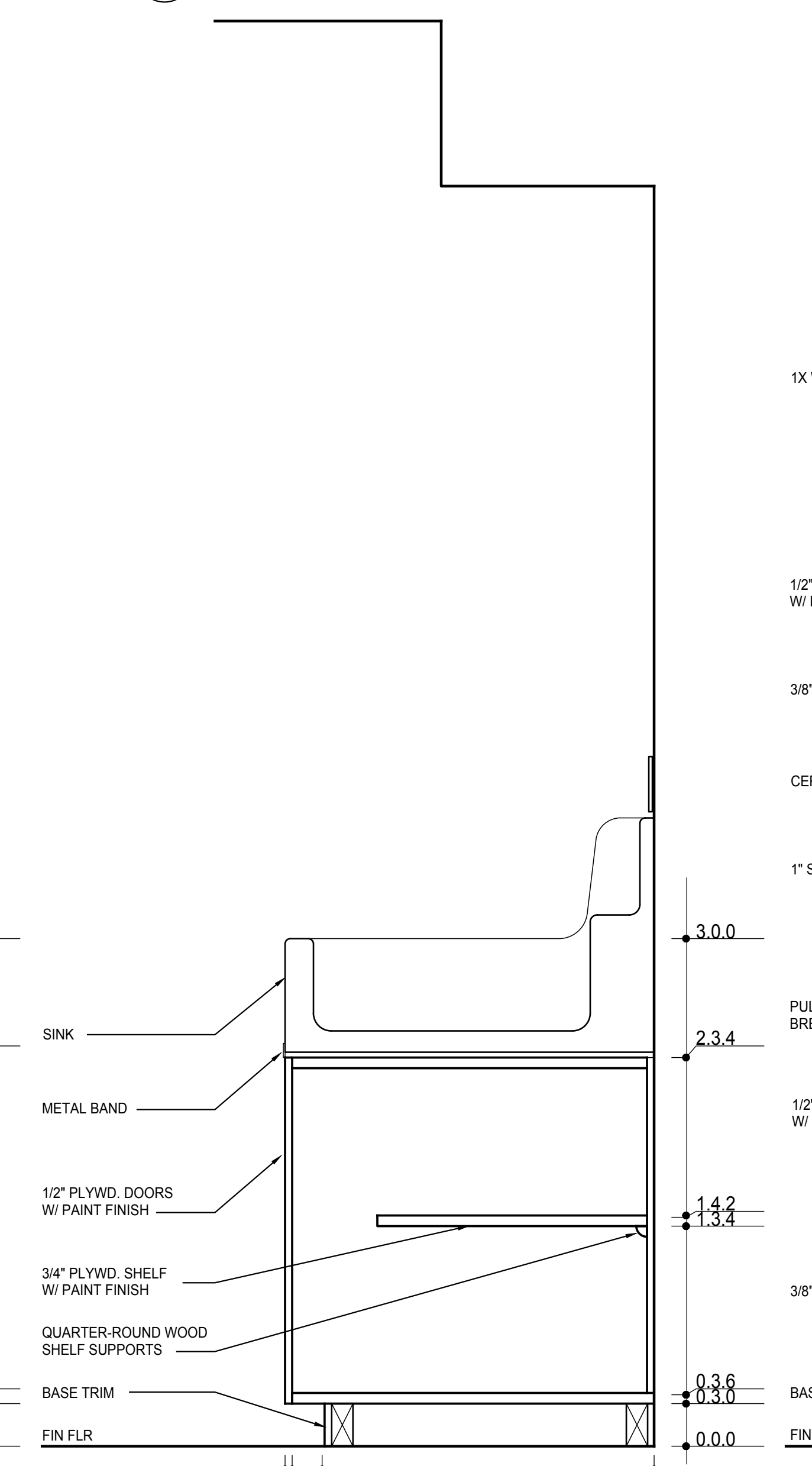

06c SINK CABINET (R - SHELF)
1-1/2" = 1'-0"

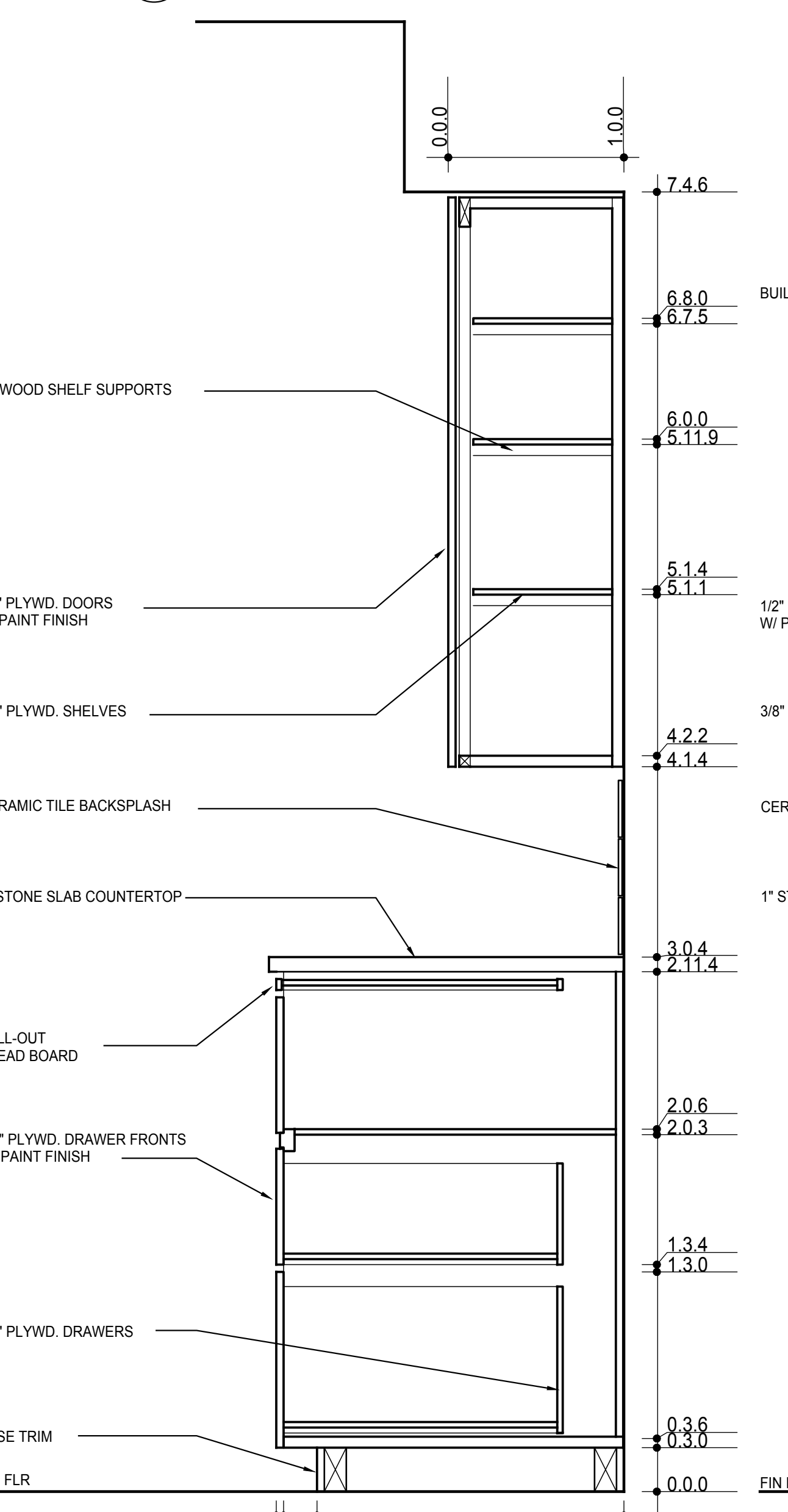

07 CAB. RIGHT SIDE OF SINK
1-1/2" = 1'-0"

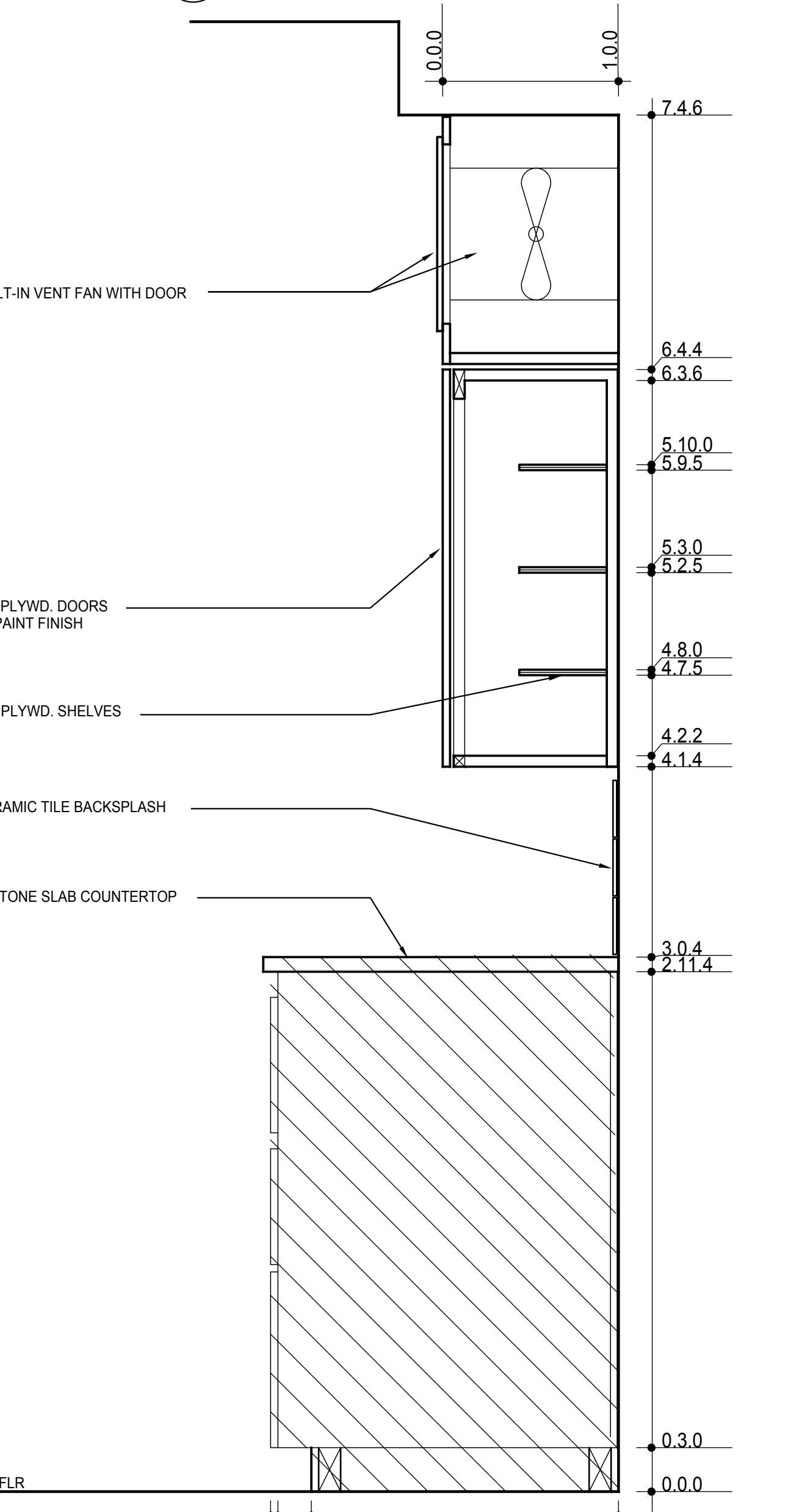

08 SPICE CABINET/ EXHAUST FAN
1-1/2" = 1'-0"

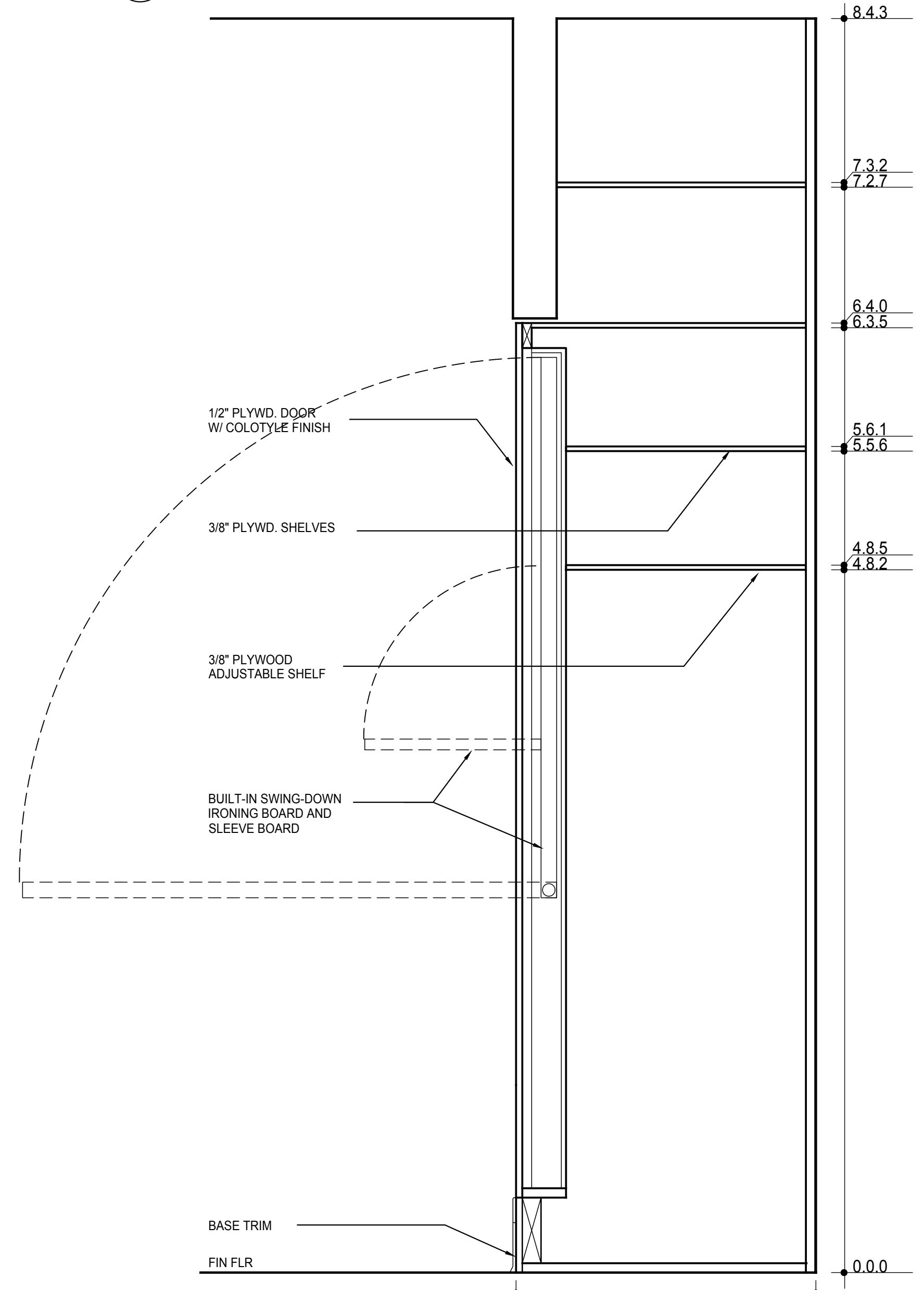

09a IRONING BOARD/PANTRY CABINET (L)
1-1/2" = 1'-0"

REV#	DATE	NAME
01	03/31/2023	DRAFT SUBMITTAL

HOUSE OF TOMORROW
HABS LEVEL 1 DOCUMENTATION
4907 86TH AVENUE EAST, PUYYALLUP, WA 98371

CABINET SECTIONS
SCALE: 1-1/2" = 1'-0"
SHEET NUMBER:
DAB/BDP

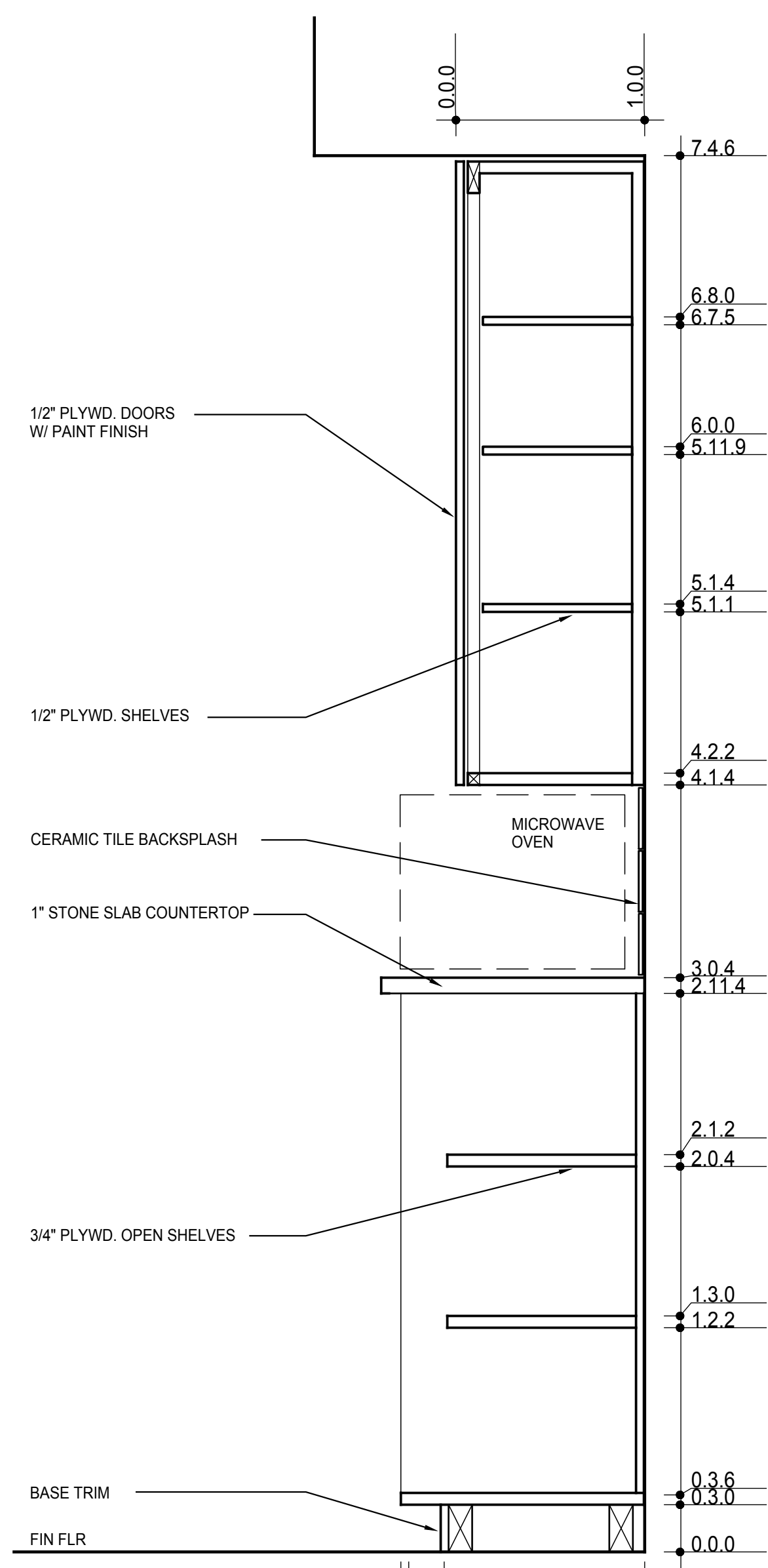

10b MICROWAVE CABINET (R) OPEN SHELVES
1-1/2" = 1'-0"

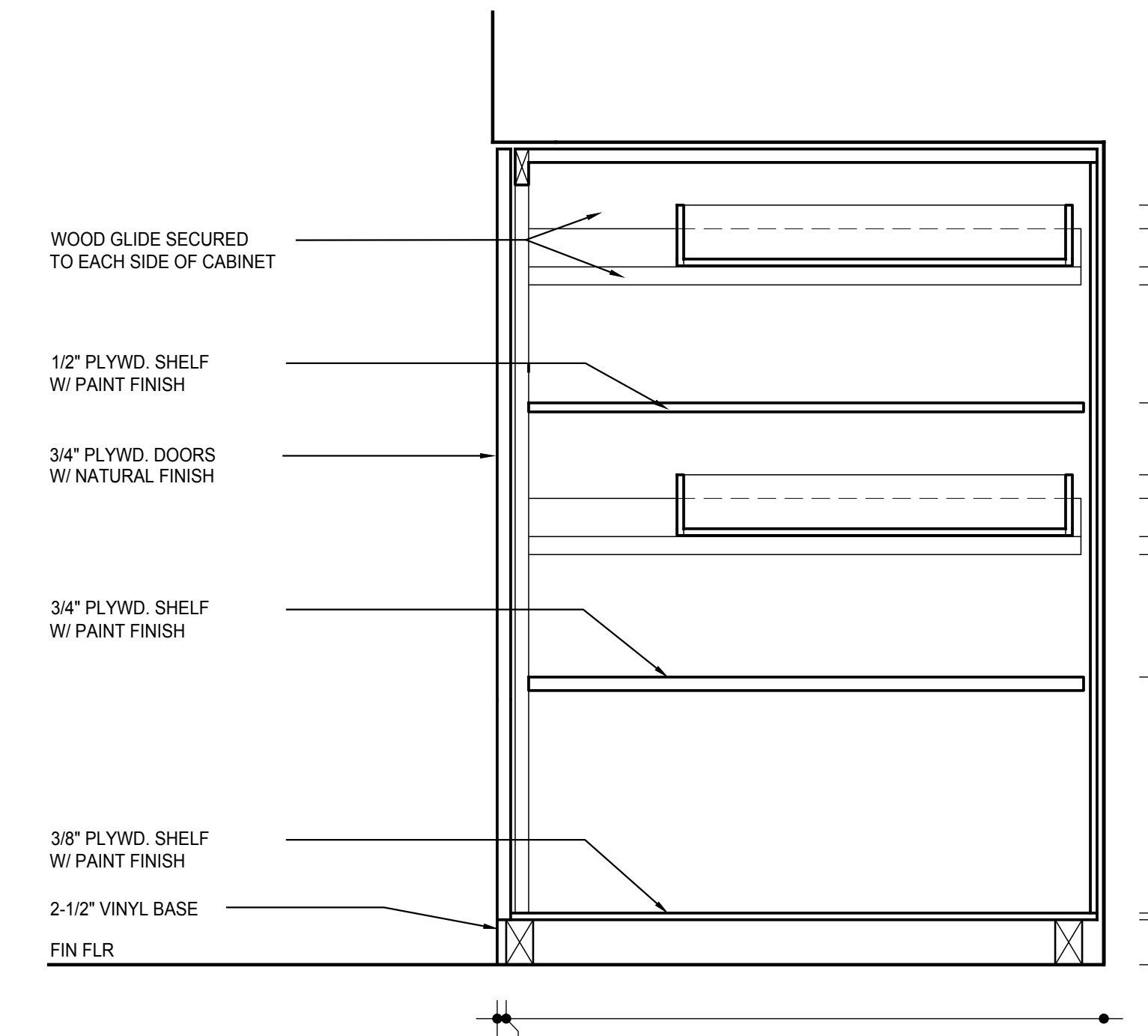

11 UNDER-STAIR CABINET
1-1/2" = 1'-0"

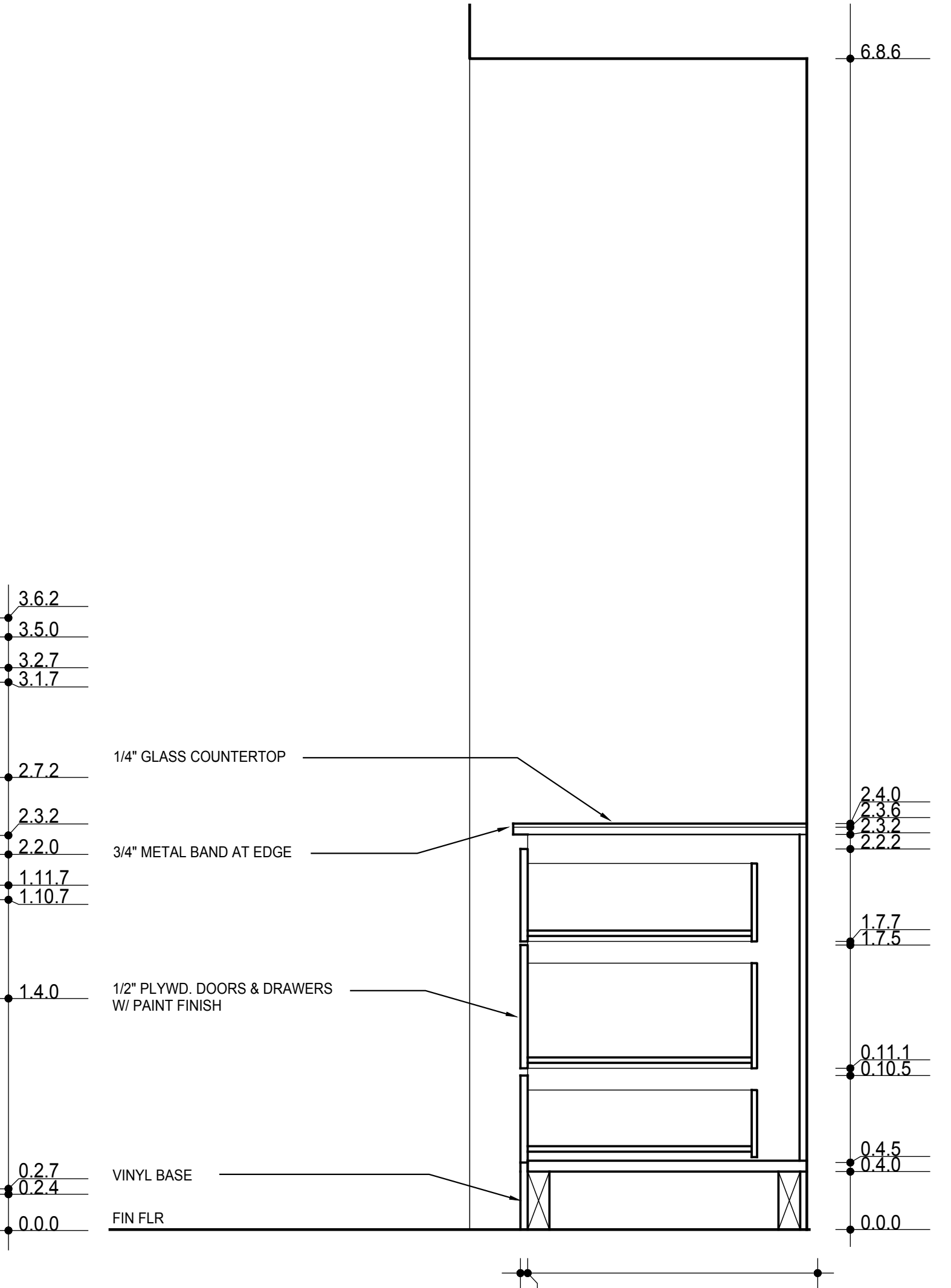

01a BATH VANITY CABINET (L)
1-1/2" = 1'-0"

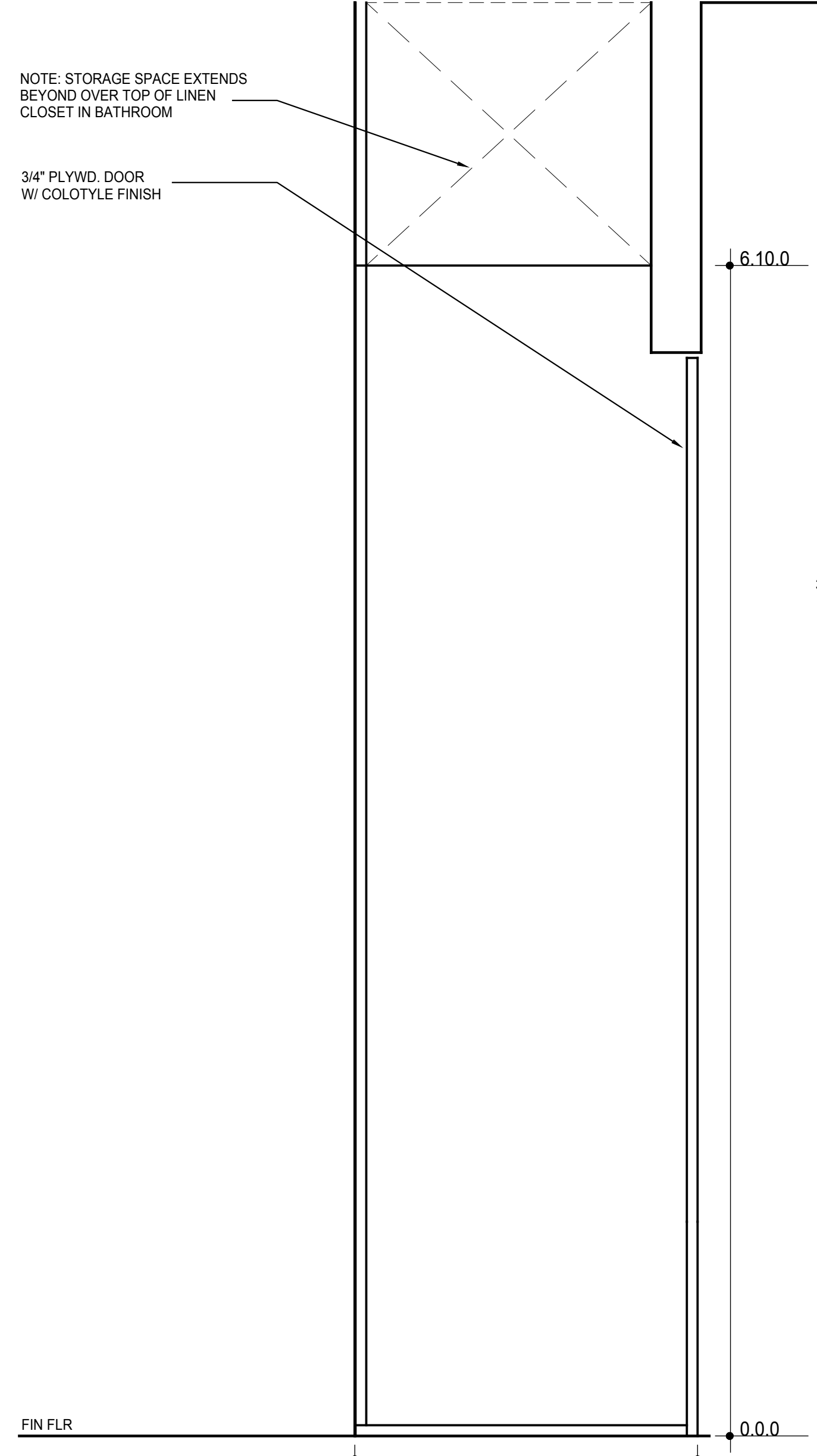

09b PANTRY CABINET (R)
1-1/2" = 1'-0"

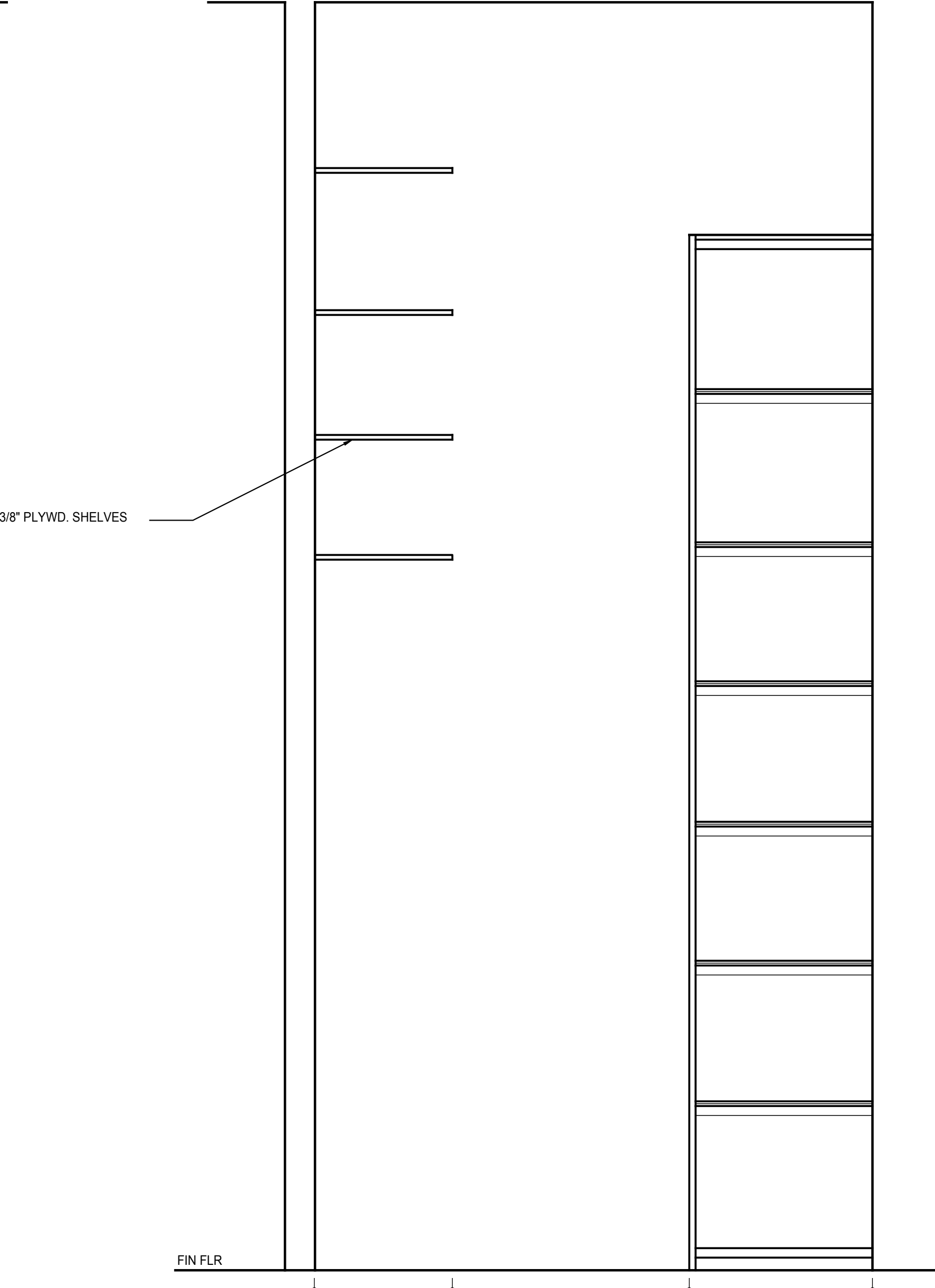

09c PANTRY/LINEN CABINET - SECTION
1-1/2" = 1'-0"

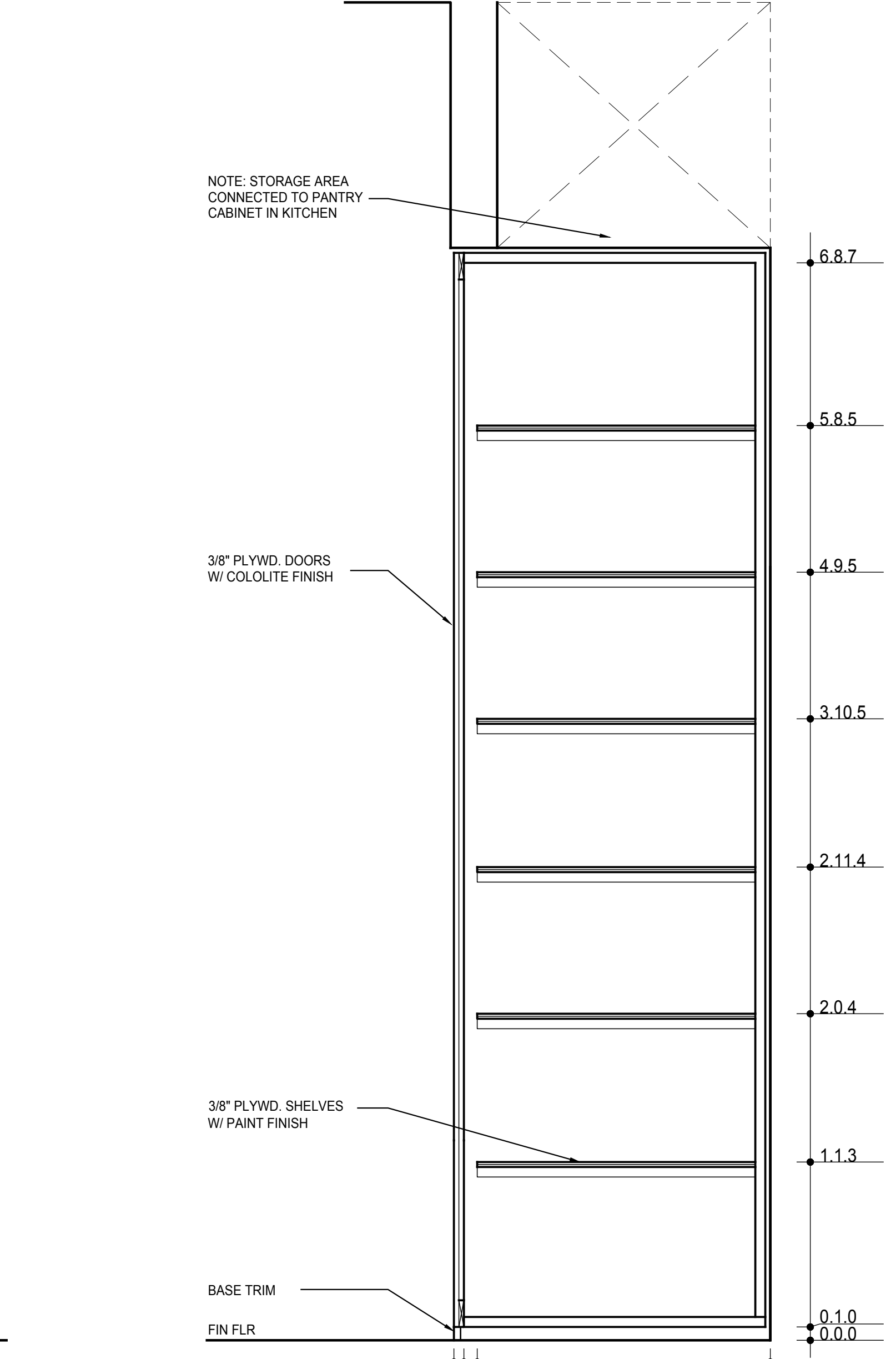

02 BATH LINEN CABINET
1-1/2" = 1'-0"

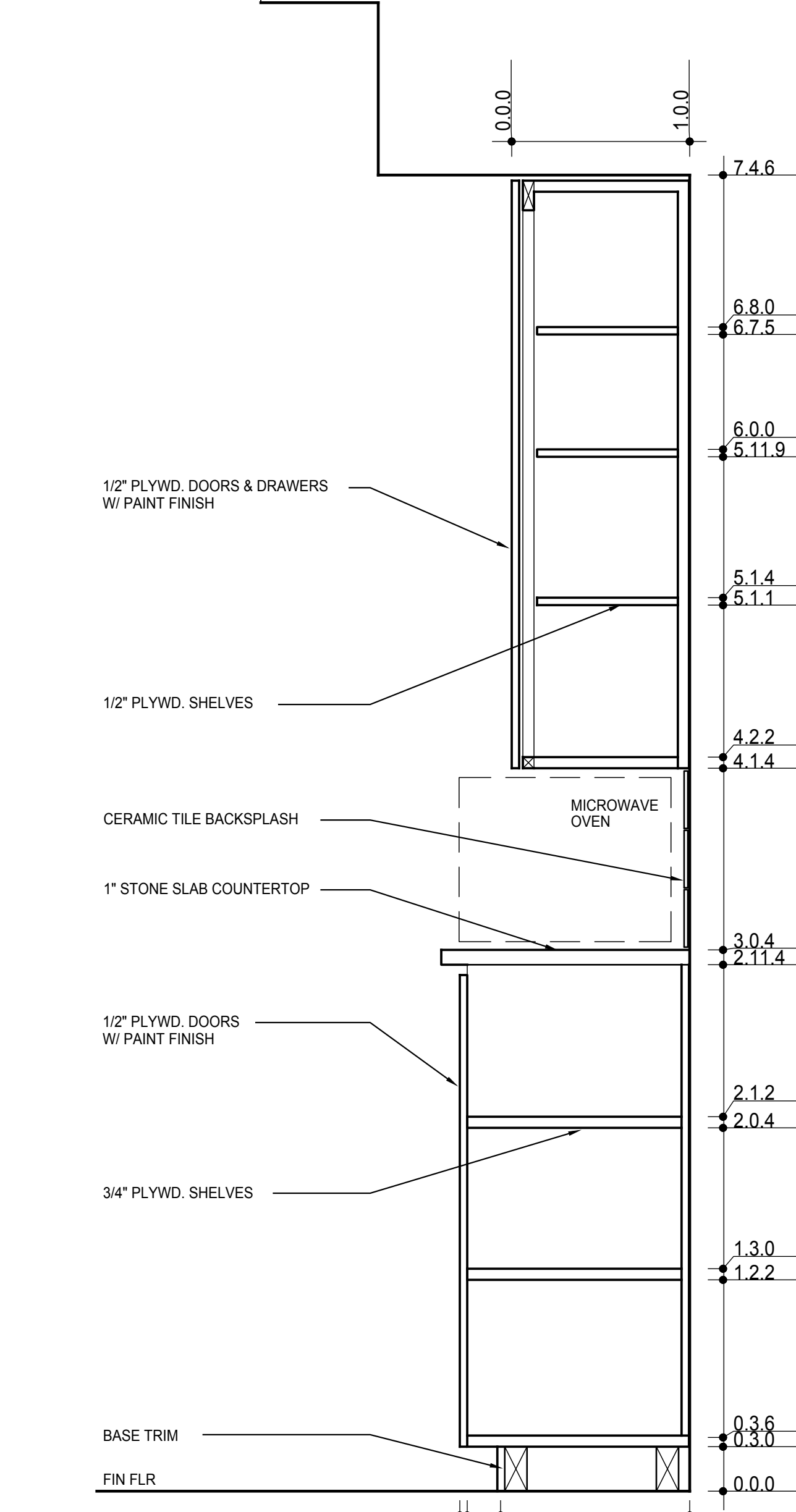

10a MICROWAVE CABINET (L)
1-1/2" = 1'-0"

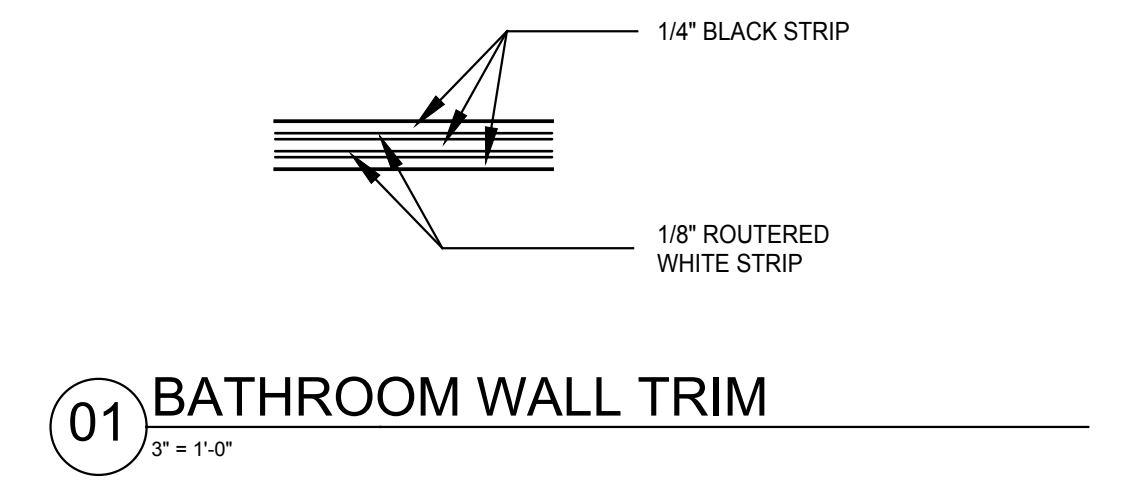

01 BATHROOM WALL TRIM
3" = 1'-0"

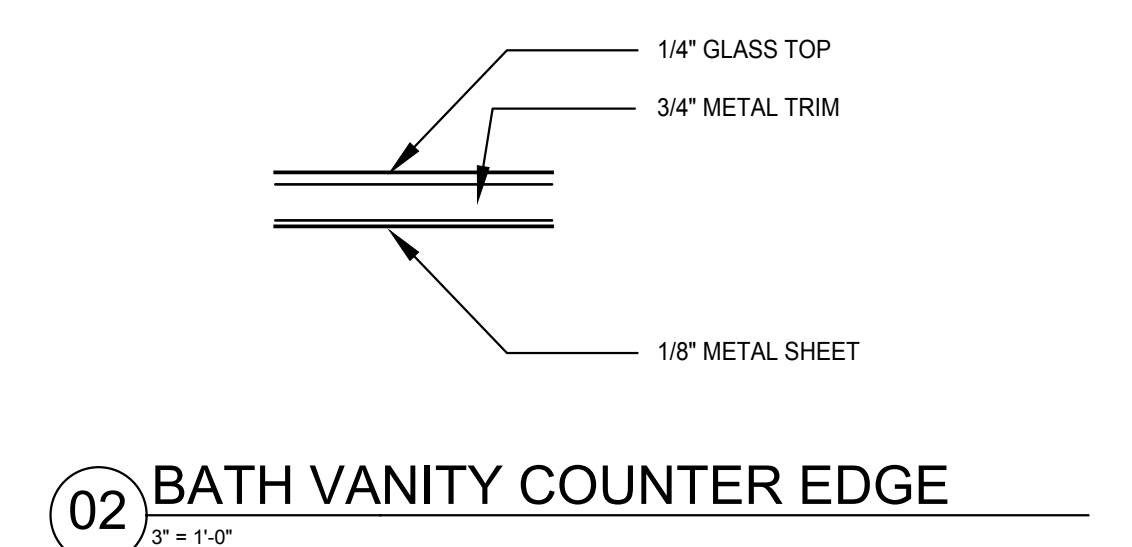

02 BATH VANITY COUNTER EDGE
3" = 1'-0"

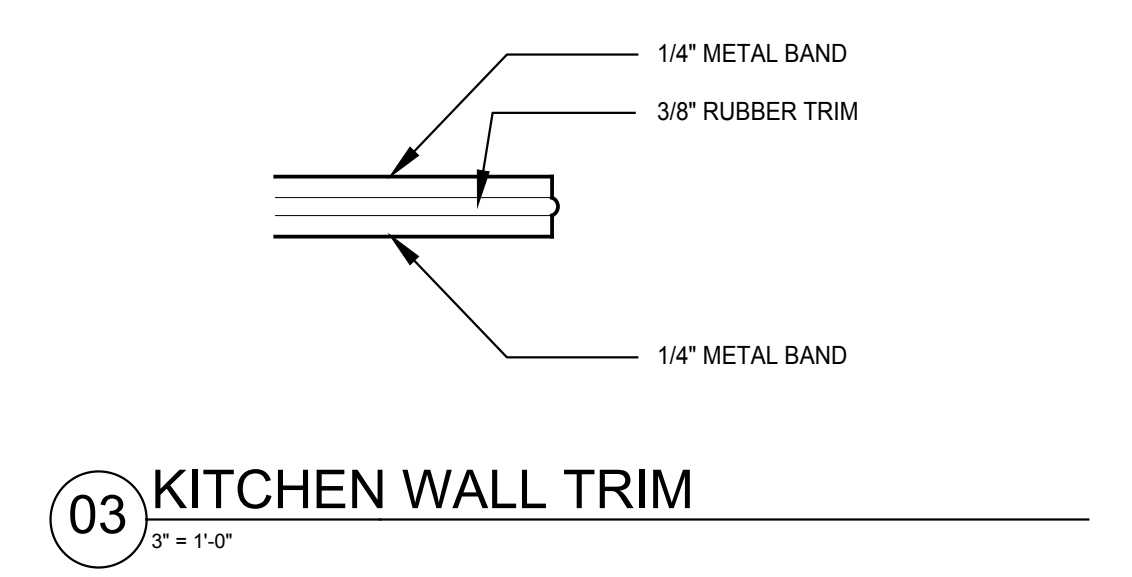

03 KITCHEN WALL TRIM
3" = 1'-0"

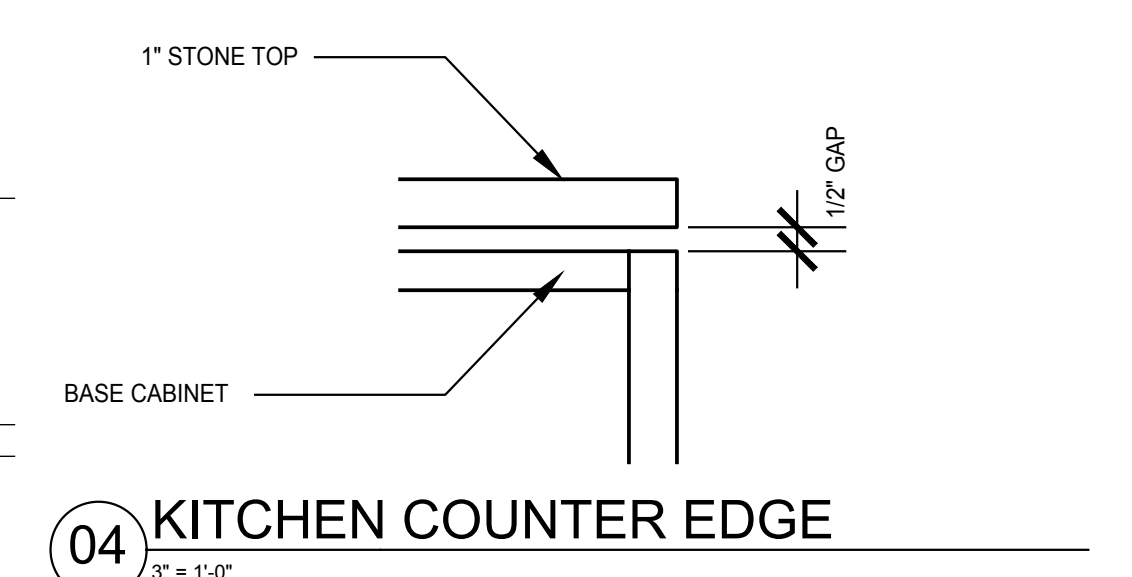

04 KITCHEN COUNTER EDGE
3" = 1'-0"

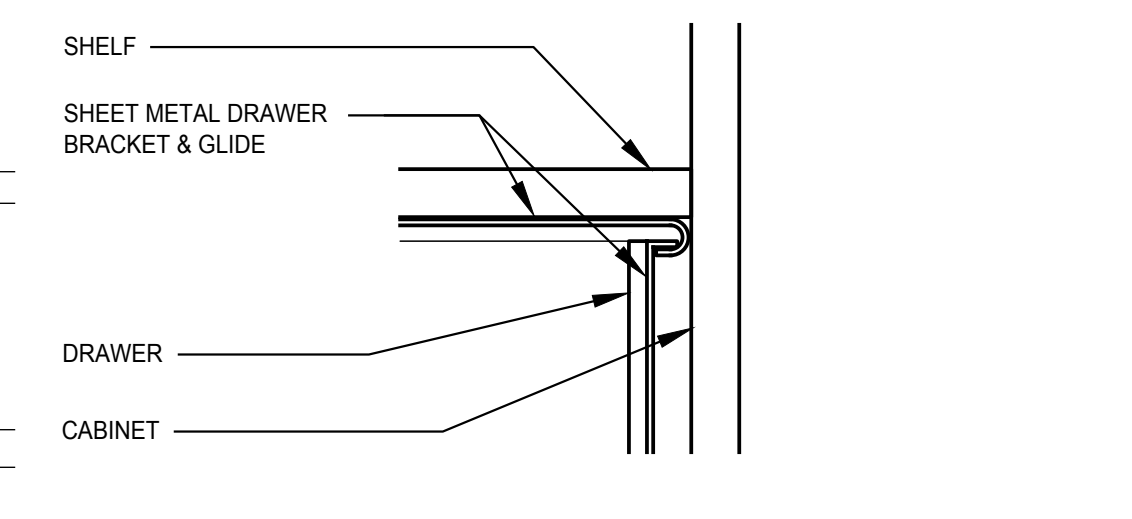

05 KITCHEN CABINET DRAWER GLIDE
3" = 1'-0"

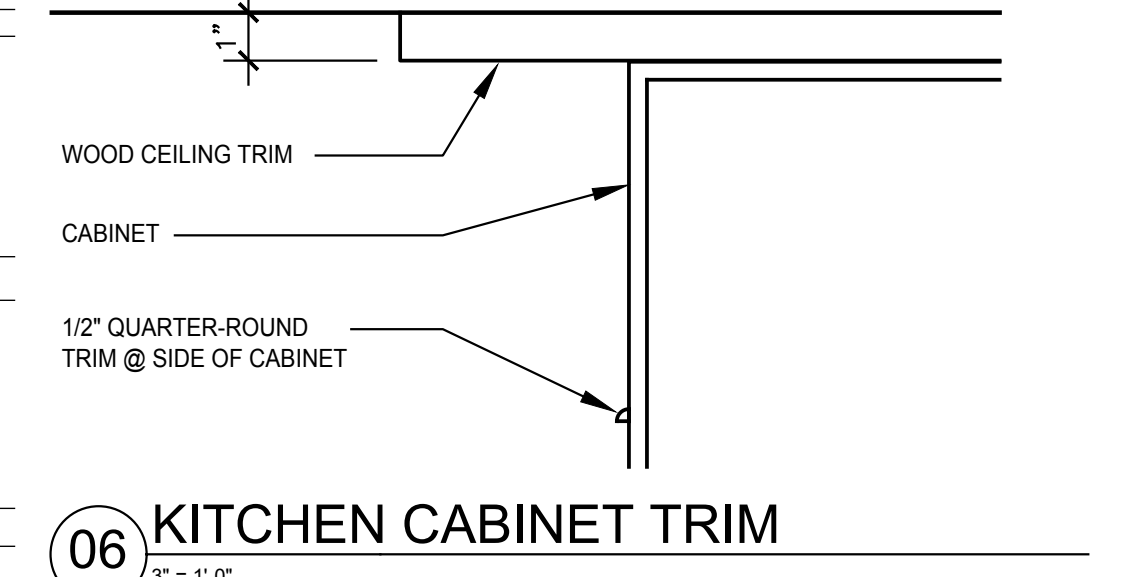

06 KITCHEN CABINET TRIM
3" = 1'-0"

